



*FASTUS is a product brand of OPTEX FA.

C-MOS Laser Displacement Sensor CD2H Series

User's Manual

Before using this product, read this manual carefully.

Keep this manual at hand so that it can be used whenever necessary.

Store the manual in a secure location.



Introduction



Thank you for purchasing this C-MOS Laser Displacement Sensor CD2H Series.
Before using this product, please read this user's manual carefully to ensure proper use.
Read this manual thoroughly, and then keep this manual at hand so that it can be used whenever necessary.



Safety Precautions

Safety precautions for ensuring safe operation of the C-MOS Laser Displacement Sensor CD2H Series are displayed as follows with the following symbols.

Precautions listed here describe important information about safety. Make sure to follow them accordingly.















■ Safety Symbols

The safety precaution symbols used and their meanings are listed below.

 Warning	Indicates that any improper operation or handling may result in moderate or minor injury, and in rare cases, serious injury or death. Also indicates a risk of serious property damage.
 Caution	Indicates that any improper operation or handling may result in minor injury or property damage.

■ Precautions

Warning

	This product cannot be used in applications that directly or indirectly detect human bodies for the purpose of ensuring safety. Do not use this product as a detection device for protecting the human body.
	Do not disassemble, repair, modify, deform under pressure, or attempt to incinerate this product. Doing so may cause injury or fire.
	This product does not have a function that stops the emission of light from the laser during disassembly. Do not disassemble the product.
	Do not use this product in water or in a location where it may be exposed to water. Do not use this product if wet. Doing so may cause a fire or damage the product.
 	This product is not explosion-proof and should not be used around flammable or explosive gases or liquids. Doing so may cause ignition resulting in an explosion or fire.
 	Do not use air dusters or any spray that uses flammable gas around the product or on the inside of the product. Doing so may cause ignition resulting in an explosion or fire.
	Do not install this product in any of the following locations. Doing so may cause a fire, damage, or a malfunction. <ol style="list-style-type: none"> 1. Locations where dust, salt, iron powders, or vapor (steam) is present. 2. Locations subjected to corrosive gases or flammable gases. 3. Locations where oil or chemical splashes may occur. 4. Locations where heavy vibrations or impacts may occur. 5. Locations where the ambient temperature exceeds the rated range. 6. Locations subject to rapid temperature changes (or where condensation occurs). 7. Locations with strong electric or magnetic fields. 8. Locations subject to direct light.
	Do not use the product at voltages or with AC power supplies that exceed the rated voltage. Doing so may cause a fire or damage the product.
	This is a class A product. In a domestic environment this product may cause radio interference, in which case the user may be required to take adequate measures.
	This product is not intended for use with nuclear power, railways, aviation, vehicles, medical equipment, food-handling equipment, or any application where particular safety measures are required. Absolutely do not use this product for any of these fields.
	Do not use this product outdoors. It is specially designed for indoor applications.
	Do not look directly at the laser beam or intentionally shine the laser beam in another person's eyes. Doing so may have adverse affects on the eyes, including temporary blindness.
	What to do in the event of a malfunction such as smoke being emitted from the product If you detect any malfunction including emission of smoke, abnormal smells or sounds, or the body becoming very hot, immediately stop operating the product and turn off the sensor power. Failure to do so may cause a fire. Repairing the product is dangerous and should in no way be performed by the customer. Contact an OPTEX FA sales representative for repairs.

Warning



What to do if water enters the product

If water or any other liquid enters the product or the cable, immediately stop operating the product and turn off the power. Using the product in this condition may cause a fire.

Caution

- Make sure to turn the power off before wiring the cable or connecting/disconnecting the connector. Performing work while the product is energized may damage it or cause electric shock.
- Do not wire with high voltage cables or power lines. Doing so may cause malfunction or damage by induction.
- Do not excessively twist or apply stress to the cable or place items on it. When connecting or disconnecting the connector, make sure to hold it by the connector portion. Do not pull on the cable.
- Do not drop the product or subject the product to strong impacts. Doing so may damage the product.
- Follow the instructions in this manual or the specified instruction manual when wiring the product or the dedicated controller for the correct wiring method. Incorrect wiring can damage the product or the controller, or cause a malfunction.
- Do not bend the cable when below the freezing point. Doing so may cause the cable to break.
- Install this product as far away as possible from high-voltage equipment, power equipment, equipment that generates large switching surges, inverter motors, welders, or any equipment that can be a source of noise.
- Do not touch the product, the cable, or the connector with wet hands. Doing so may damage the product or cause electric shock.
- Use the dedicated connector cable for connecting the product. Use of anything other than the dedicated cable may cause a malfunction or damage the product.
- Tighten the sensor head mounting screws (included screws or the like) with a tightening torque of no more than 0.8 N·m. Excessive tightening torque may damage the sensor head.
- Use the product and dedicated controller within the rated ranges.
- Install this product and dedicated controller securely. Failure to ensure secure installation may result in the products falling and becoming damaged.
- During operation, this product becomes very hot. Do not touch it for long time. Doing so may cause a low-temperature burn.
- The $\varnothing 0.7$ mm hole on the side of the sensor (The side opposite the laser warning label. See "5-2 Dimensions.") is a watertight ventilation hole. To maintain the degree of protection, do not cover this hole or insert a sharp object into it.

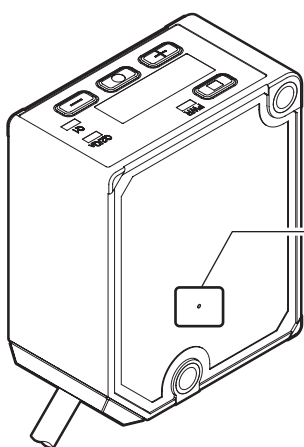

Air vent

* Do not cover the air vent with stickers or other items.

* If the sensor is mounted on a flat surface, there will be sufficient space for the offset of the mounting holes to prevent problems.

■ NOTICE

- After carefully considering the intended use, required specifications, and usage conditions, install and use the product within the specified ranges.
- All specifications may be changed without notice.
- When using this product, it is the responsibility of the customer to ensure necessary safety designs in hardware, software, and systems in order to prevent any threat to life, physical health, and property due to product malfunction or failure.
- Do not use this product for the development of weapons of mass destruction, for military use, or for any other military application. Moreover, if this product is to be exported, comply with all applicable export laws and regulations, including the “Foreign Exchange and Foreign Trade Act” and the “Export Administration Regulations,” and carry out the necessary procedures pursuant to the provisions therein.
- Before using this product, fully examine the applicable environmental laws and regulations, and operate the product in conformity to such laws and regulations. OPTEX FA does not assume any responsibility for damages or losses occurring as a result of noncompliance with applicable laws and regulations.
- If this product will be exported to the United States, approval must first be obtained from the FDA (Food and Drug Administration), the laser regulating body of the United States.
- A report for this product has been submitted to the CDRH (Center for Devices and Radiological Health).
- If installing this product in your own equipment, ensure that the product is properly handled according to the laws and regulations of the relevant country or region.

■ Precautions for Laser Use

- This product emits a Class 1 or Class 2 visible laser beam that is compliant with JIS C6802 / IEC 60825-1 laser safety standards.

Laser Class 1



Symbol	Meaning
	Laser emission
LASER 1	Class 1 laser product
	Laser aperture

Laser Class 2



Symbol	Meaning
	Laser emission
LASER 2	Class 2 laser product
	Do not look directly at the beam
	Laser aperture

Laser warning label position

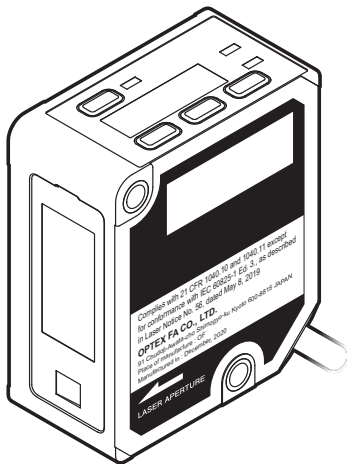

Type of laser used in this product

Type	Red semiconductor laser
Wavelength	655 nm
Maximum output	0.39 mW/1 mW
Pulse duration	Variable within 0.5 μ s to 5 ms
Repetition	Variable within 200 Hz to 7.5 kHz

Expressions Used in This Manual



This section explains the expressions used in this manual.

Note

Indicates an item that requires special attention during operation

MEMO

Indicates information that is useful to know during operation

Included display images

Note that display images included in this user's manual are subject to change without prior notice due to product improvements.

Contents

Introduction	i
Safety Precautions	ii
Expressions Used in This Manual	vii

1 Product Overview

1-1	Included Items	1-2
1-1-1	Options	1-2
1-2	Part Names and Functions	1-3
1-3	Mounting the Sensor.....	1-4
1-4	I/O Circuit Diagrams	1-7
1-5	Power On Settings.....	1-8
1-6	Operation Examples for Major Applications.....	1-9
1-6-1	Setting the Current Measured Value to Zero	1-9
1-6-2	Using Analog Current Output (4 to 20 mA)	1-10
1-6-3	Using Analog Voltage Output (0 to 10 V)	1-11
1-6-4	Using Control Outputs	1-12

2 Main Menu

2-1	Main Menu	2-2
2-1-1	Switching the Main Menu	2-2
2-1-2	Recording	2-5
2-1-3	Measured Value Display (Relative Value)	2-5
2-1-4	Measured Value Display (Absolute Value)	2-6
2-1-5	Measured Value Display (Bar)	2-7
2-1-6	Analog value	2-8

2-1-7	Mode	2-9
2-1-8	Recording	2-9
2-1-9	[Reference] Status Icons	2-10

3 Settings Menu

3-1	[A] Measurement	3-2
3-1-1	Basic Key Operations for Configuring Settings	3-2
3-1-2	[A1] Sampling period	3-3
3-1-3	[A2] Moving average	3-4
3-1-4	[A3] Median filter	3-5
3-1-5	[A6] Measurement direction	3-5
3-1-6	[A7] Measured value offset	3-6
3-1-7	[A8] Span Teach, Auto	3-7
3-1-8	[A9] Span Teach, Manual	3-9
3-1-9	[A11] Mask near / [A12] Mask far	3-11
3-1-10	[A16] Error mode	3-12
3-1-11	[A17] Set clamp value	3-13
3-1-12	[A18] Error hold time	3-13
3-2	[B] Output 1 (DO1) Settings.....	3-14
3-2-1	Key Operations for Configuring Settings	3-14
3-2-2	[B1] Output1 Mode	3-16
3-2-3	[B6] DO1 Teach 1 Auto / [B7] DO1 Teach 2 Auto	3-21
3-2-4	[B8] DO1 Teach 1 Manual / [B9] DO1 Teach 2 Manual	3-22
3-2-5	[B11] DO1 Edge Min.	3-22
3-2-6	[B12] DO1 Edge Max.	3-22
3-2-7	[B13] DO1 Switch direction	3-23
3-2-8	[B14] DO1 Cycle offset	3-23
3-2-9	[B16] DO1 Output mode	3-24
3-2-10	[B17] DO1 Delay timer	3-25
3-2-11	[B18] DO1 Timer set	3-26
3-2-12	[B19] DO1 Hysteresis	3-27

	3-2-13	[B20] DO1 Tolerance	3-27
	3-2-14	[B21] DO1 Edge hold	3-27
3-3		[C] Output 2/Analog Output (DO2/AO) Settings	3-28
	3-3-1	Key Operations for Configuring Settings	3-28
	3-3-2	[C1] Output2 Mode	3-30
	3-3-3	[C31] Analog Teach 4mA Auto / [C32] Analog Teach 20mA Auto	3-30
	3-3-4	[C36] Analog Teach 0V Auto / [C37] Analog Teach 10V Auto	3-30
	3-3-5	[C33] Analog Teach 4mA Manual / [C34] Analog Teach 20mA Manual	3-31
	3-3-6	[C38] Analog Teach 0V Manual / [C39] Analog Teach 10V Manual	3-31
	3-3-7	[C6] DO2 Teach 1 Auto / [C7] DO2 Teach 2 Auto	3-35
	3-3-8	[C8] DO2 Teach 1 Manual / [C9] DO2 Teach 2 Manual	3-35
	3-3-9	[C11] DO2 Edge Min.	3-35
	3-3-10	[C12] DO2 Edge Max.	3-35
	3-3-11	[C13] DO2 Switch direction	3-35
	3-3-12	[C14] DO2 Cycle offset	3-35
	3-3-13	[C16] DO2 Output mode	3-35
	3-3-14	[C17] DO2 Delay timer	3-36
	3-3-15	[C18] DO2 Timer set	3-36
	3-3-16	[C19] DO2 Hysteresis	3-36
	3-3-17	[C20] DO2 Tolerance	3-36
	3-3-18	[C40] DO2 Edge hold	3-36
3-4		[D] Input	3-38
	3-4-1	Key Operations for Configuring Settings	3-38
	3-4-2	[D1] Input Function	3-39
	3-4-3	[D2] Input Hold Mode	3-41
	3-4-4	[D4] Input delay	3-45
	3-4-5	[D5] Input mode	3-45
3-5		[E] Device	3-46
	3-5-1	Key Operations for Configuring Settings	3-46
	3-5-2	[E1] Reset factory settings	3-47

3-5-3	[E2] Reset customer settings	3-47
3-5-4	[E3] Save customer settings	3-47
3-5-5	[E4] Span Teach Reset	3-47
3-5-6	[E6] Language	3-48
3-5-7	[E7] No of decimal places	3-48
3-5-8	[E11] Display off time	3-48
3-5-9	[E12] Display brightness	3-48
3-5-10	[E13] Rotate display	3-49
3-5-11	[E16] Laser	3-49
3-5-12	[E17] Output NPN/PNP/PP	3-49
3-6	[F] Information.....	3-50
3-6-1	Key Operations for Configuring Settings	3-50
3-6-2	[F1] Model number	3-50
3-6-3	[F2] Serial number	3-50
3-6-4	[F3] Firmware version	3-51
3-6-5	[F6] Sensor operating hours	3-51
3-6-6	[F7] Laser operating hours	3-51
3-6-7	[F8] Internal temperature	3-51
3-6-8	[F11] Error count	3-51
3-6-9	[F13] Error history	3-52

4 IO-Link

4-1	IO-Link Master UR Series Connection Operation Settings.....	4-2
4-1-1	Connecting the CD2H and the UR	4-2
4-1-2	Functions When Connecting the CD2H and the UR	4-2
4-2	Front Panel Operations of the UR	4-4
4-2-1	Overview of Display Operations	4-4
4-2-2	Master Parameters Display	4-5
4-2-3	Device Identification Display	4-7
4-3	Index List	4-11

4-4	Process Data Format.....	4-19
4-5	Events and Errors.....	4-22
4-5-1	Events	4-22
4-5-2	Errors	4-22
4-6	CD2H_URES_Navigator.....	4-23
4-6-1	Functions of CD2H_URES_Navigator	4-23
4-6-2	System configuration for CD2H_URES_Navigator	4-23
4-6-3	Connecting	4-24

5 Specifications

5-1	Specifications.....	5-2
5-1-1	Measurement Specifications	5-2
5-1-2	Common Specifications	5-2
5-2	Dimensions.....	5-5
5-3	Typical Characteristics.....	5-7
5-3-1	Spot Size	5-7
5-3-2	Interference Area	5-9
5-3-3	Light Axis Area	5-12

6 Troubleshooting

6-1	Troubleshooting	6-2
-----	-----------------------	-----

7 Menu Tree

Index



Product Overview

This chapter provides an overview of the product.

1-1 Included Items

Sensor ×1

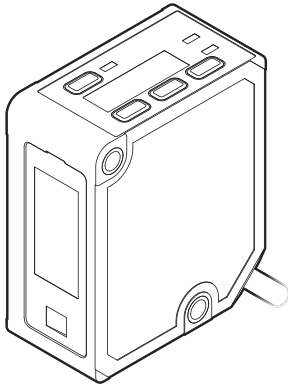

Instruction manual:
English × 1, Japanese × 1

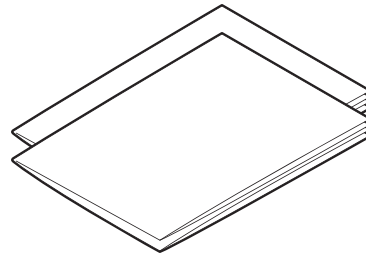

M4×35 mm mounting screws ×2

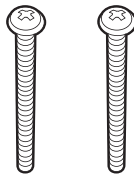

Washers, M4 nuts ×2 sets

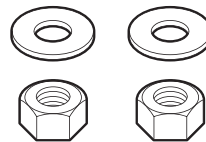

1-1-1 Options

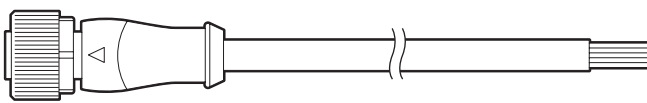

M12 5-pin straight open-end cables:

- YF2A15-020VB5XLEAX: 2 m
- YF2A15-050VB5XLEAX: 5 m
- YF2A15-100VB5XLEAX: 10 m

Minimum bending radius: 26 mm (when fixed in place)

M12 5-pin straight open-end bending resistant cables:

- DOL-1205-G02M-R: 2 m
- DOL-1205-G05M-R: 5 m

Minimum bending radius: 10 mm (when fixed in place)

30 mm (when movable)

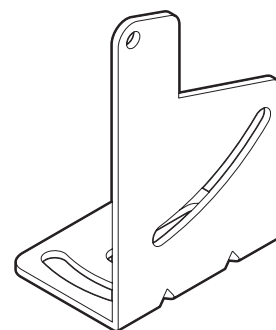

Mounting bracket
BEF-WN-OD2000-B

1-2 Part Names and Functions

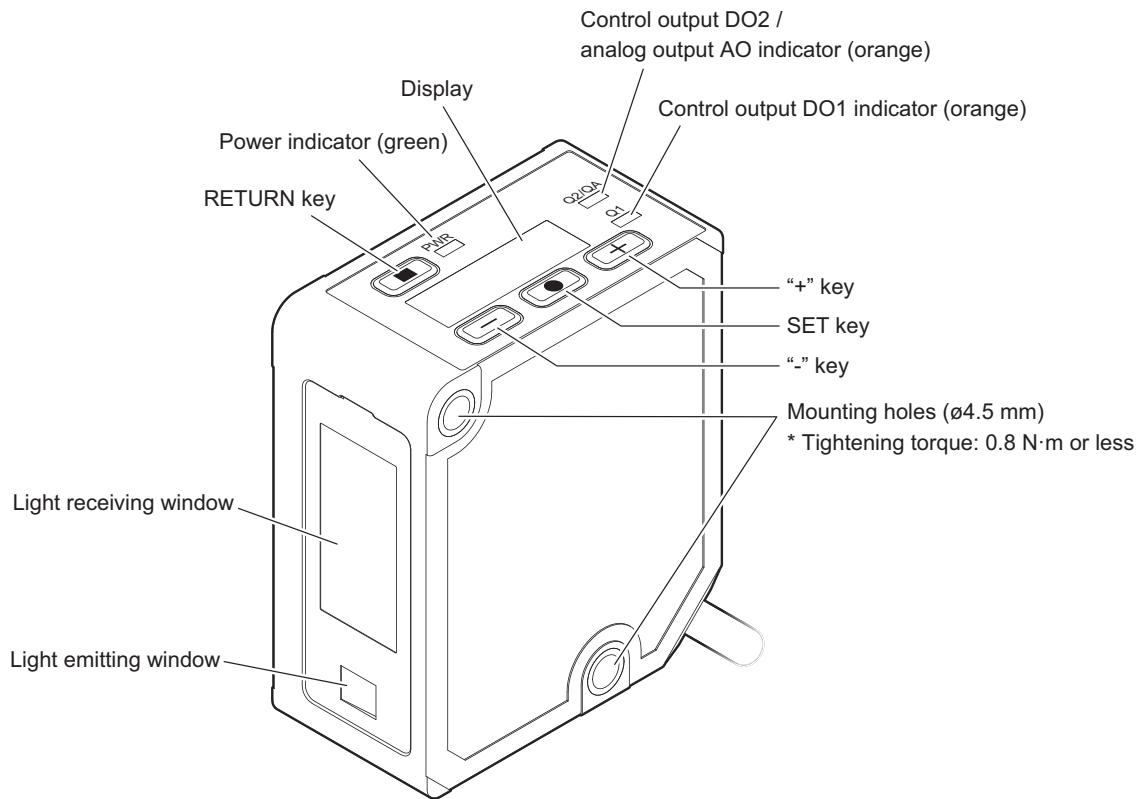

Name	Status
Power indicator (green)	When the power is on: Lit at all times With an IO-Link connection: Flashing
Control output DO1 indicator (orange)	When output is on: Lit
Control output DO2 / analog output AO indicator (orange)	When set to control output: Lit when output is on When set to analog output: Lit when the measured object is present between the distance set to 4 mA (0 V) and that set to 20 mA (10 V)

1-3 Mounting the Sensor

Note

Take care to observe the following when handling the sensor head cable. Excessive stress on the cable may lead to breakage.

- Do not pull on the cable with a force of 30 N or more.
- The minimum bending radius should be at least twice the diameter of the cable when fixed in place or at least six times the cable diameter when movable.
- Make sure there is at least 30 mm between the sensor head and any bend in the cable.
- Tighten the sensor head mounting screws (included screws or the like) with a tightening torque of no more than 0.8 N·m.

Excessive tightening torque may damage the sensor head.

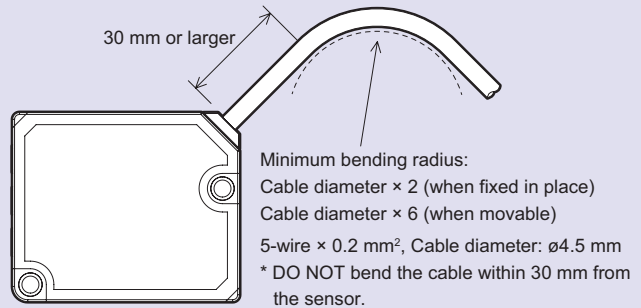

■ Mounting

Mount the sensor head to a wall or bracket using the included screws (or equivalent screws).

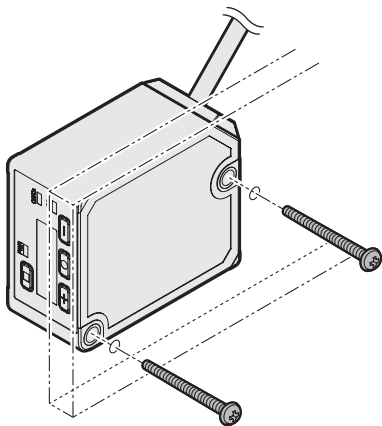

■ Notes on installation

Adjust the laser beam so that it irradiates the measured object as close to perpendicular as possible.

- Diffuse reflection setting

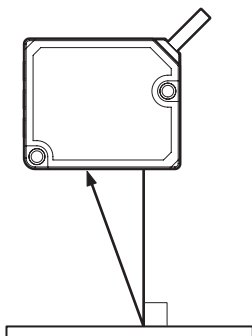

To ensure high detection accuracy and stability, mount the sensor as shown for the applicable target.

● With height differences

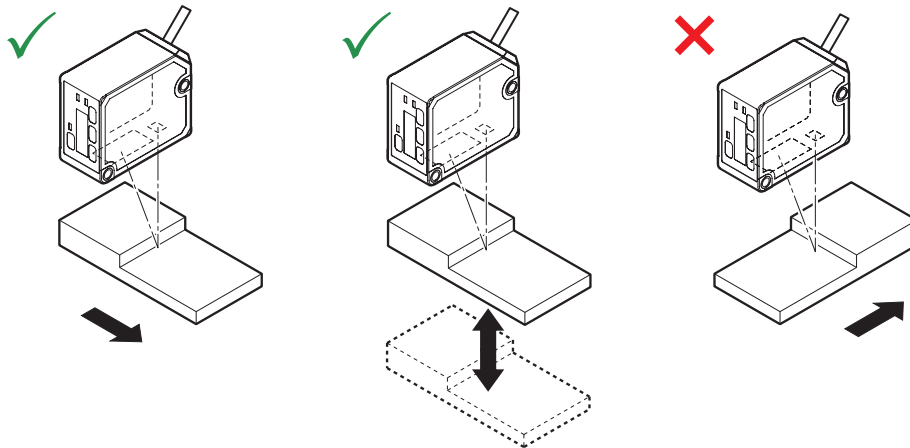

● With material/color differences

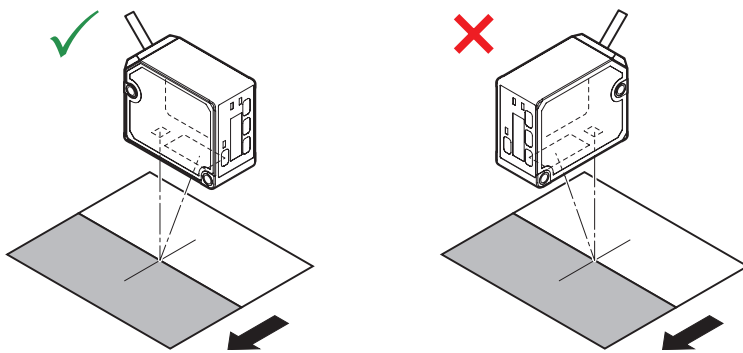

● With rotating measurement targets

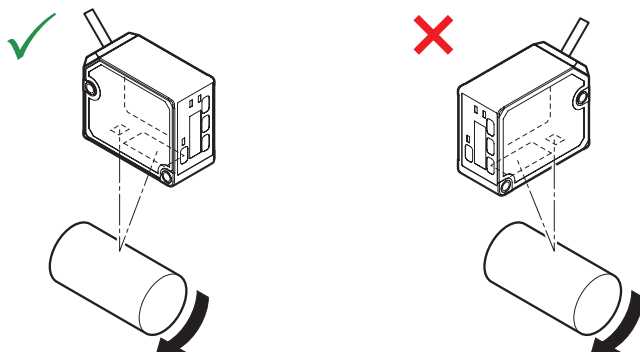

● With holes or recesses

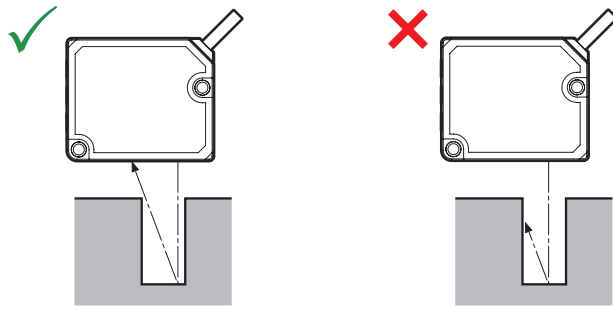

● When mounted on a wall

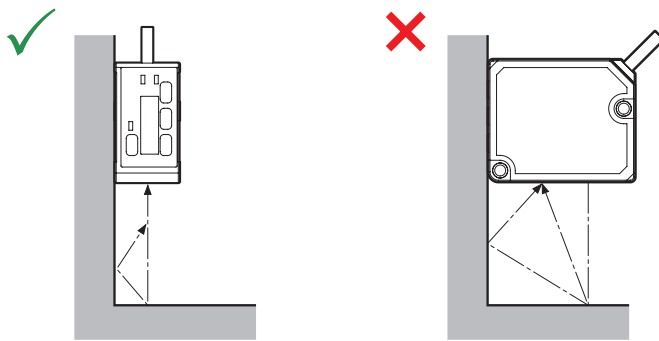

Attach the sensor head so that the detection side (emitting/receiving surfaces) is parallel to the detection target.

Adjust the installation so that the spot aligns with the detection position, and check whether the Control output DO2 / analog output AO indicator (orange) lights up (default setting).

Note

■ Warmup

Wait approximately 30 minutes after turning on the power before use. Measurements performed directly after turning on the power will gradually drift (change) over time.

■ Effects of dirt and dust

Measurement errors may occur due to dirt or dust as well as water or oil.

- If the glass cover or the surface of the measured object becomes dirty, remove the dirt by blowing it off with clean air.
- If the glass cover becomes excessively dirty, wipe it with a soft cloth.

1-4 I/O Circuit Diagrams

SIO mode (standard I/O mode) with the NPN setting

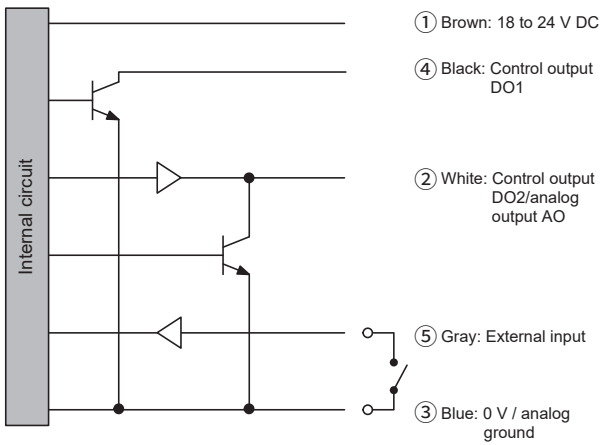

SIO mode (standard I/O mode) with the PNP setting

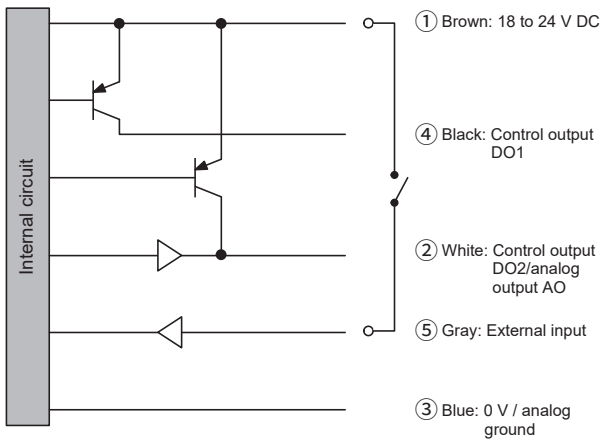

IO-Link mode or the Push-pull setting

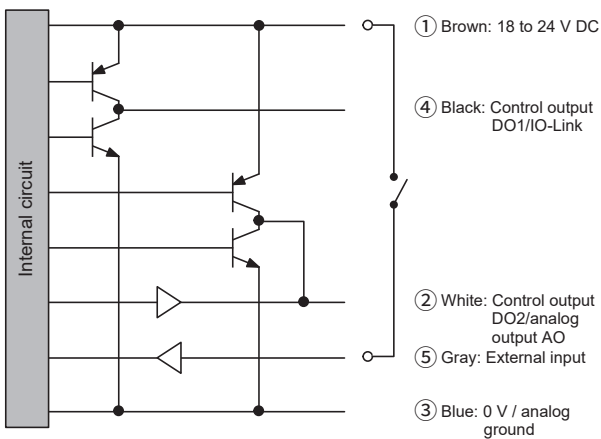

M12 connector pin assignments

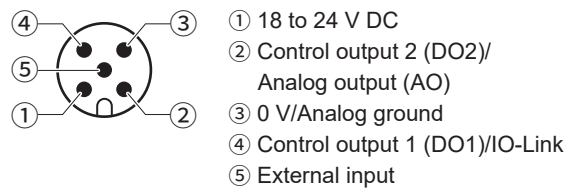

1-5 Power On Settings

When the power is first turned on, "Initial Setting" will be displayed. Select the display language and control output to proceed.

The information provided in this user's manual is based on the display language being set to "English."

"Initial Setting" will also be displayed if "Reset factory settings" is executed. Select the display language and control output in the same way as when the power was first turned on.

See page 3-47 for more information on resetting to factory settings.

The following describes the key operations and display transitions after the power is first turned on with English selected as the display language and NPN selected as the control output.

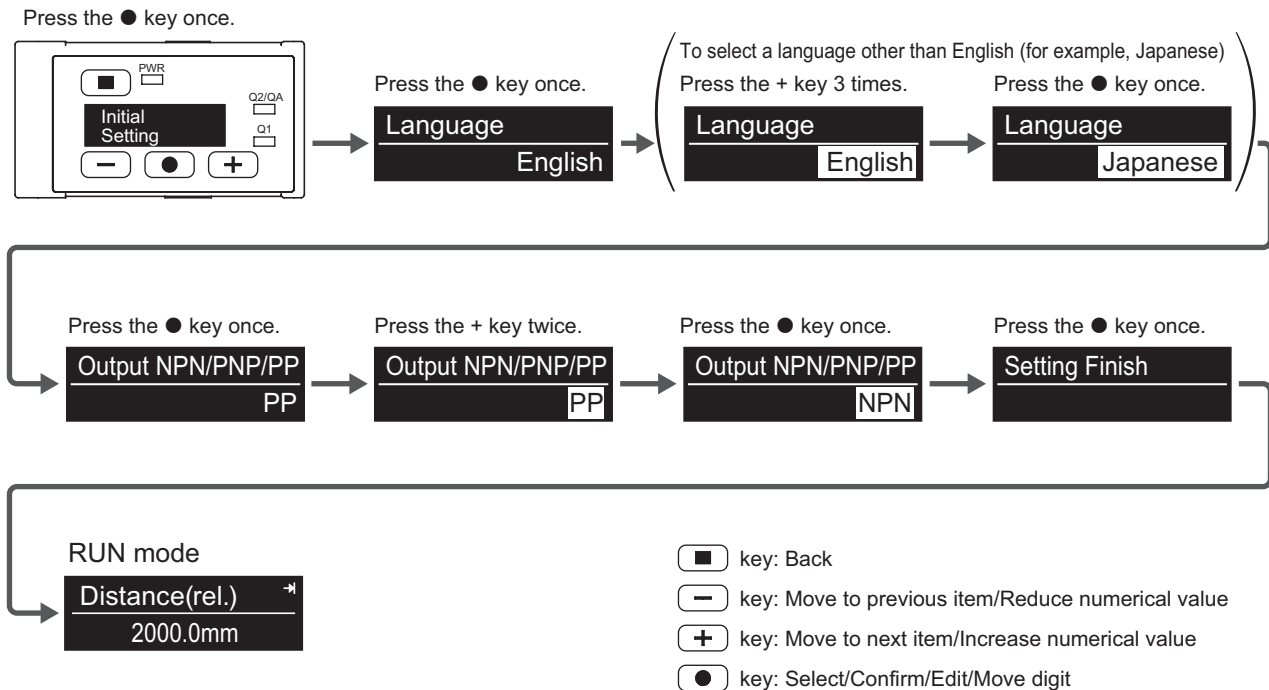

1-6 Operation Examples for Major Applications

1-6-1 Setting the Current Measured Value to Zero

■ Setting the display to zero using the keys on sensor

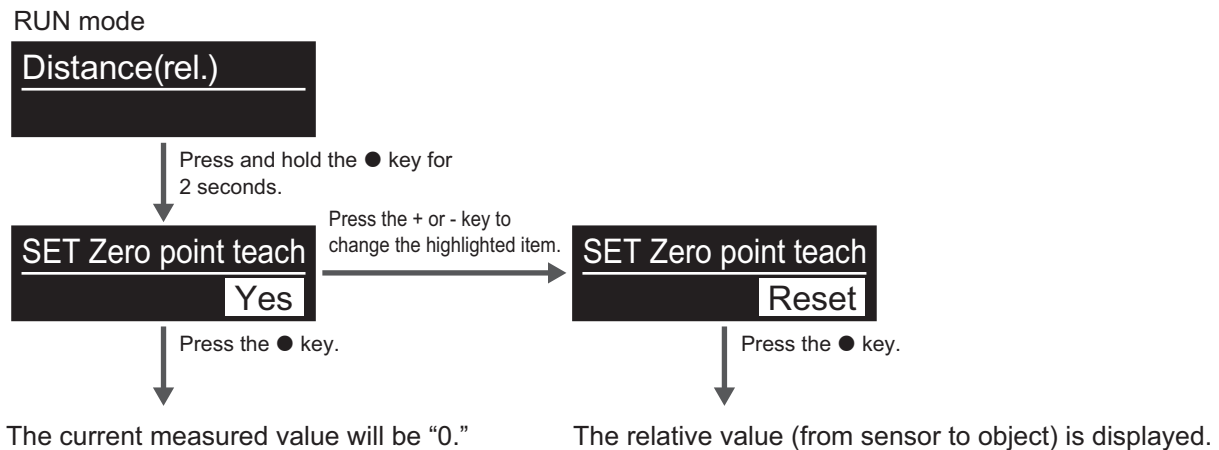

■ Setting the display to zero by external input

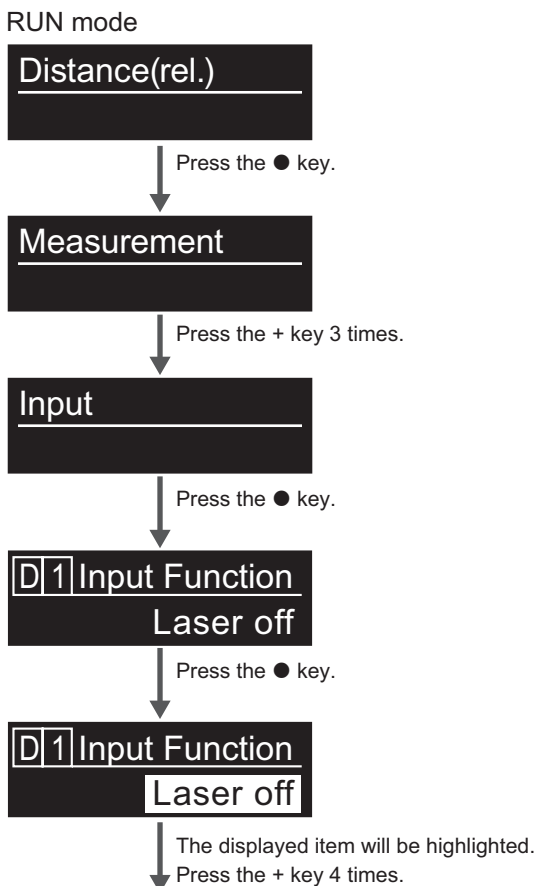

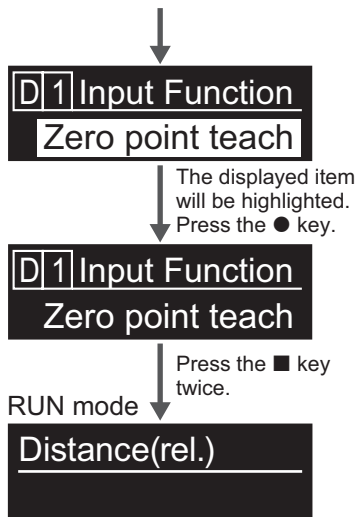

“Trigger on” selected as the input mode

- When NPN output is selected:
The external input wire (gray wire) and ground wire (blue wire) are short-circuited, and the current value is set as zero.
- When PNP/PP (push-pull) output is selected:
The external input wire (gray wire) and power supply wire (brown wire) are short-circuited, and the current value is set as zero.
- Releasing the “Zero point teach”:
The “Zero point teach” will be released on the falling edge when the external input is held at 1000 ms or more.

When “Trigger off” is selected as the input mode

- When NPN output is selected:
The external input wire (gray wire) and ground wire (blue wire) are open, and the current value is set as zero.
- When PNP/PP (Push-pull) output is selected:
The external input wire (gray wire) and power supply wire (brown wire) are open, and the current value is set as zero.
- Releasing the “Zero point teach”:
The “Zero point teach” will be released when the external input is held.

1-6-2 Using Analog Current Output (4 to 20 mA)

Output 2/Analog output (DO2/AO) is set to 4 to 20 mA by default.

The white wire can be used for positive analog, and the blue wire can be used for ground (same as power supply ground).

● Default settings when set to analog current output by model

	CD2H-30xxxA	CD2H-50xxxA	CD2H-130xxx	CD2H-245xxx	CD2H-350xxx	CD2H-700xxx
4 mA	-5 mm (25 mm from sensor)	-10 mm (40 mm from sensor)	-70 mm (60 mm from sensor)	-175 mm (70 mm from sensor)	-250 mm (100 mm from sensor)	-500 mm (200 mm from sensor)
20 mA	+5 mm (35 mm from sensor)	+10 mm (60 mm from sensor)	+70 mm (200 mm from sensor)	+175 mm (420 mm from sensor)	+250 mm (600 mm from sensor)	+500 mm (1200 mm from sensor)

The analog output distance range can be changed as desired (10% or more of the measurement range).

Analog output can also be set to inverted.

1-6-3 Using Analog Voltage Output (0 to 10 V)

Change the analog output setting from the default setting to analog voltage output.

The white wire can be used for positive analog, and the blue wire can be used for ground (same as power supply ground).

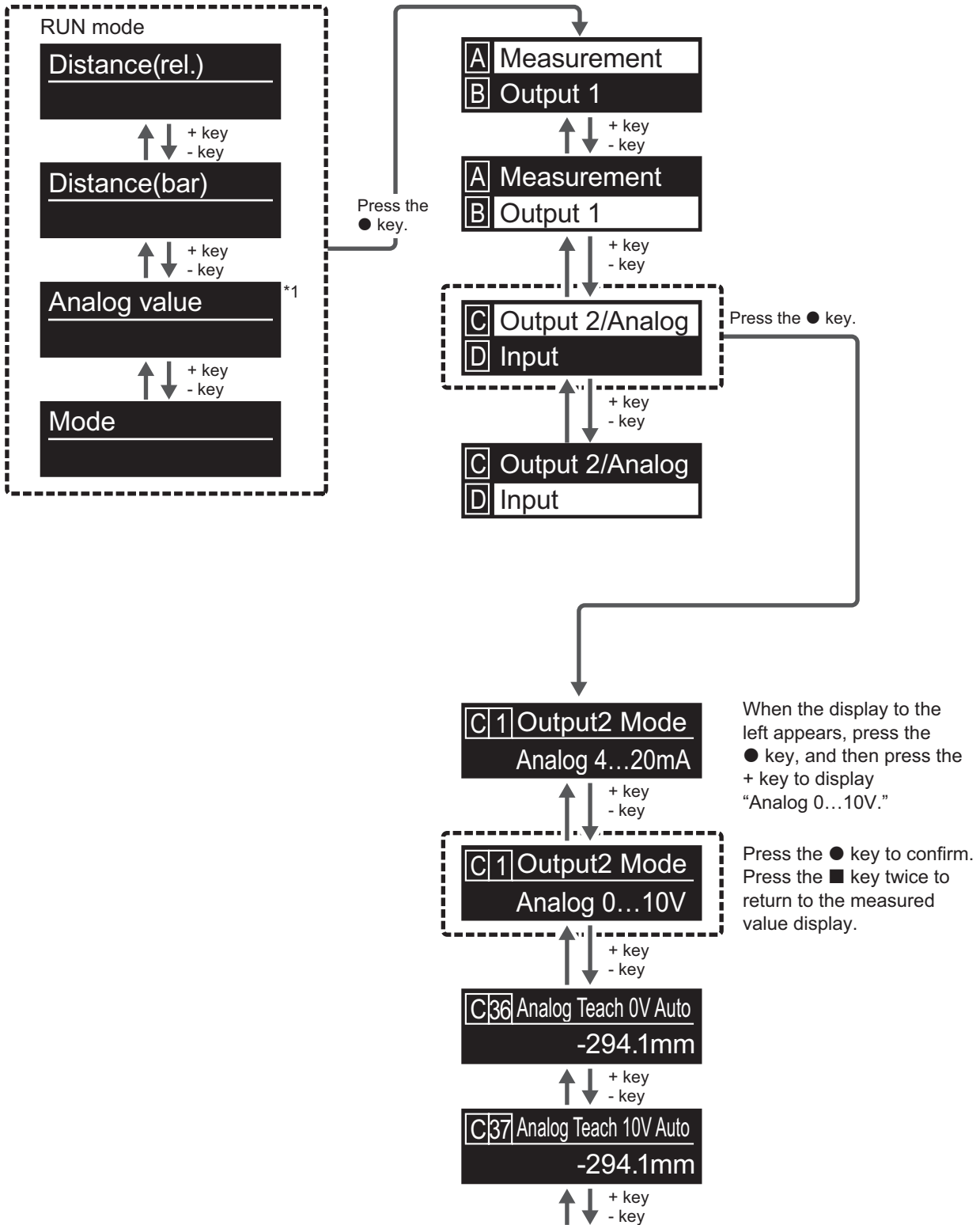

● Default settings when set to analog voltage output by model

	CD2H-30xxxA	CD2H-50xxxA	CD2H-130xxx	CD2H-245xxx	CD2H-350xxx	CD2H-700xxx
0 V	-5 mm (25 mm from sensor)	-10 mm (40 mm from sensor)	-70 mm (60 mm from sensor)	-175 mm (70 mm from sensor)	-250 mm (100 mm from sensor)	-500 mm (200 mm from sensor)
10 V	+5 mm (35 mm from sensor)	+10 mm (60 mm from sensor)	+70 mm (200 mm from sensor)	+175 mm (420 mm from sensor)	+250 mm (600 mm from sensor)	+500 mm (1200 mm from sensor)

The analog output distance range can be changed as desired (10% or more of the measurement range). Analog output and the measurement range can also be set to inverted.

1-6-4 Using Control Outputs

Output 1 (DO1) is set to 1-point teaching (detection with one threshold) by default.

The setting can be changed to Zone teaching (upper/lower limit setting detection) or FGS2 (threshold \pm tolerance level-based range detection).

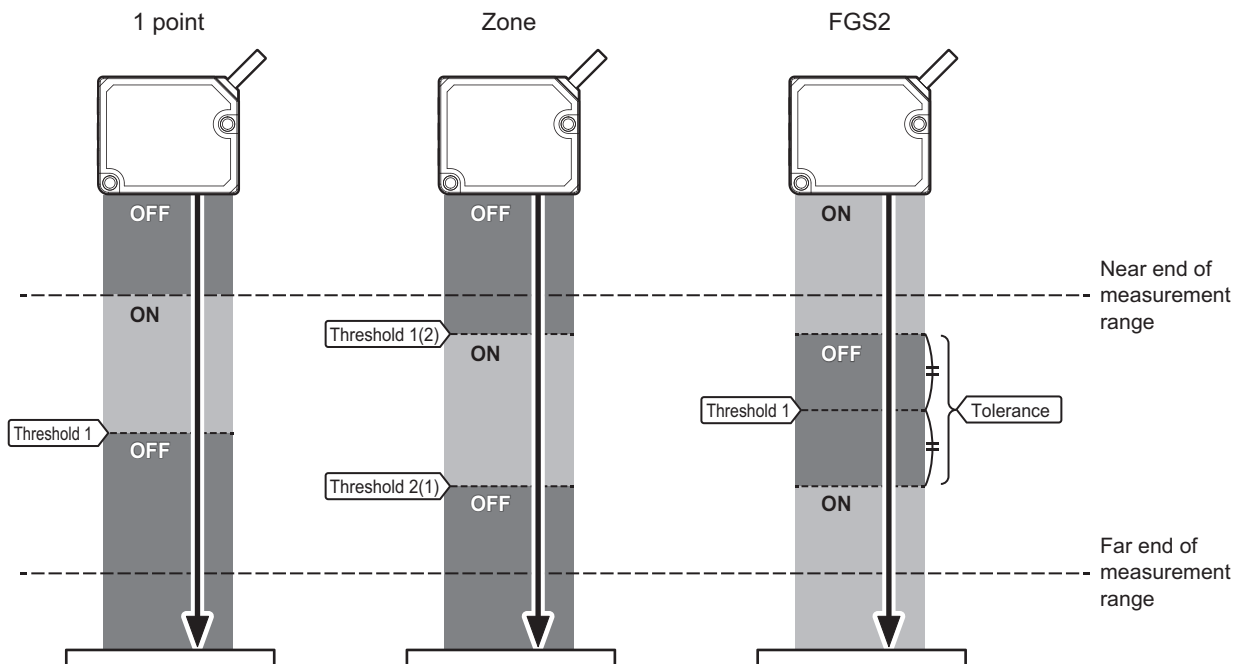

DO2 (Output 2) is set to analog current output by default, but the control output can be changed in the same way as DO1.

Control output can also be output separately for DO1 and DO2.

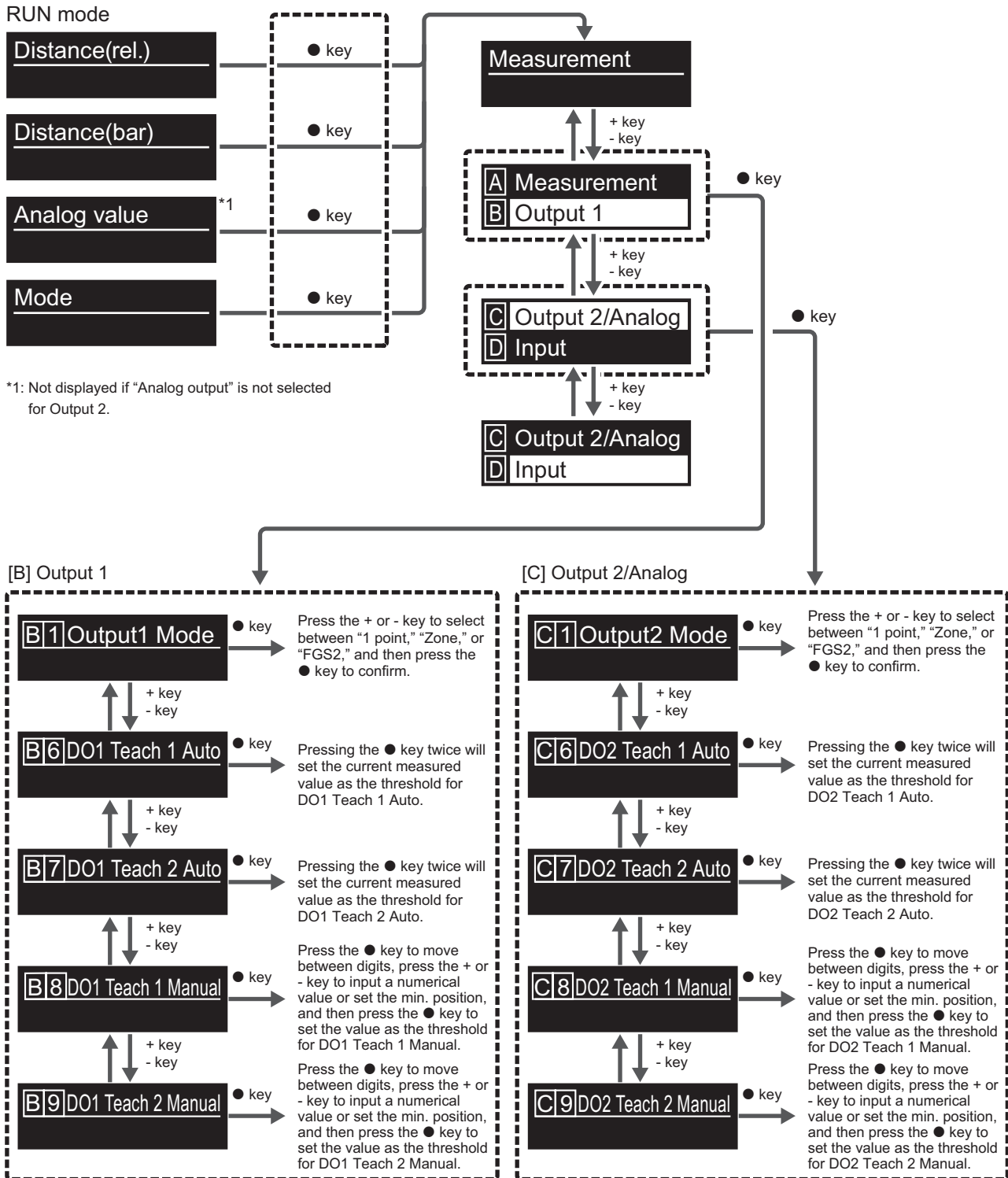

* Explanation of CD2H key functions

- key: Select/Edit/Confirm
- key: Back
- + key: Next item
- key: Previous item





2

Main Menu

Up to six menus can be accessed from the main menu, by pressing the + or - key. Press the ● key on one of these six menus to enter the advanced settings mode.

2-1 Main Menu

After “Initial Setting” (setting the display language and control output), “Distance(rel.)” is used as the main display.

2-1-1 Switching the Main Menu

Press the + or - key to switch between up to six different displays as shown below.

Press the ● key in any display to enter the advanced settings mode.

Press and hold the ● key for 2 seconds in any display to access specific functions. (See page 2-3 for more information.)

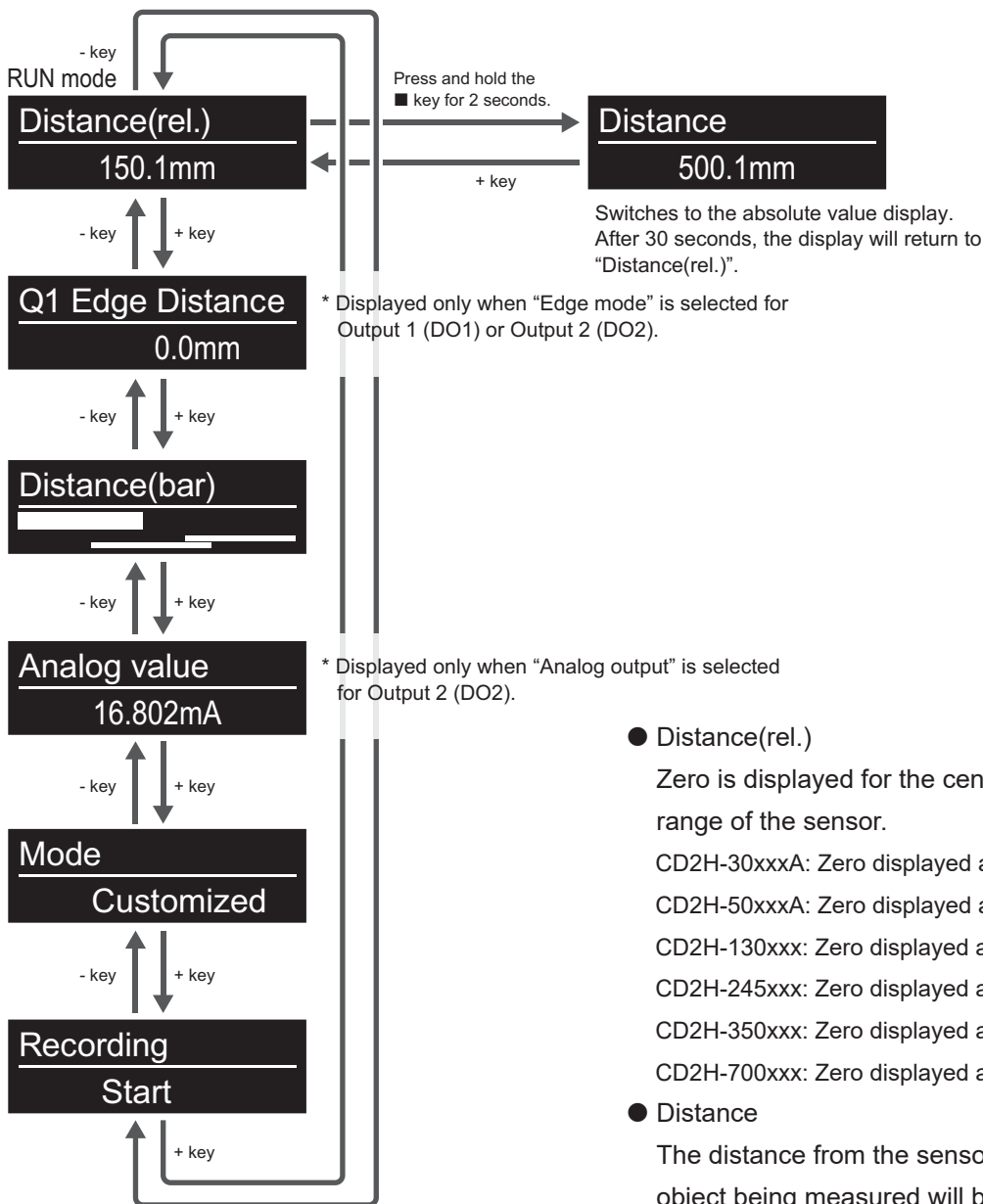

- **Distance(rel.)**
Zero is displayed for the center of the measurement range of the sensor.
CD2H-30xxxA: Zero displayed at 30 mm from object
CD2H-50xxxA: Zero displayed at 50 mm from object
CD2H-130xxx: Zero displayed at 130 mm from object
CD2H-245xxx: Zero displayed at 245 mm from object
CD2H-350xxx: Zero displayed at 350 mm from object
CD2H-700xxx: Zero displayed at 700 mm from object
- **Distance**
The distance from the sensor to the surface of the object being measured will be displayed.

(See page 2-3 to 2-9 for more information.)

RUN mode

Distance(rel.)
150.1mm

Displayed after completing "Initial Setting" or when the power is turned on.
The measurement center will be set as zero, and near-side measurements will be displayed with "-" while far-side measurements will be displayed with "+."

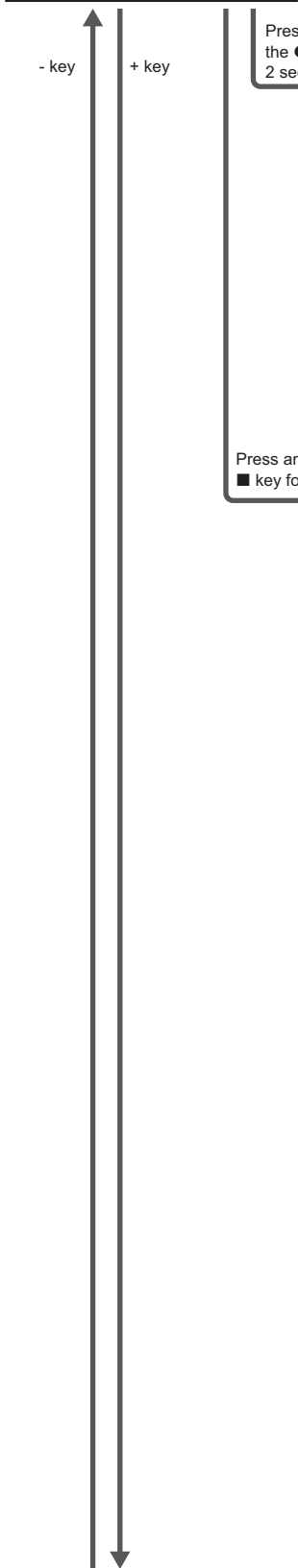

Press and hold the ● key for 2 seconds.

Acts as a shortcut to "Zero point teach."

SET Zero point teach ● key
Yes

Select "Yes" to set the currently measured value to zero.
* If analog output is being used, the displayed zeroed value will be set as the center value of the analog output range (12 mA for 4 to 20 mA, or 5 V for 0 to 10 V).

- key ↑ ↓ + key

SET Zero point teach ● key
Reset

Select "Reset" to release the "Zero point teach."

■ key

The display will return to the previous menu without making any changes.

Press and hold the ■ key for 2 seconds.

Displays the absolute distance from the sensor to the object.

Distance
500.1mm

* The display will automatically return to "Distance(rel.)" after 30 seconds. (Or press the + key to go back.)

Press and hold the ● key for 2 seconds.

SET Output1 Mode ● key
DO1 1 point

SET DO1 Teach 1 Auto ● key
150.1mm

Confirm

The displayed current measured value will be written to DO1 Teach 1 Auto as the threshold.

- key ↑ ↓ + key

SET Output1 Mode ● key
DO1 Zone

SET DO1 Teach 1 Auto ● key
-49.1mm

Confirm

The displayed current measured value will be written to DO1 Teach 1 Auto as the threshold.

- key ↑ ↓ + key

SET Output1 Mode ● key
DO1 FGS2

SET DO1 Teach 2 Auto ● key
150.1mm

Confirm

The displayed current measured value will be written to DO1 Teach 2 Auto as the threshold.

SET DO1 Teach 1 Auto ● key
150.1mm

Confirm

The displayed current measured value will be written to DO1 Teach 1 Auto as the threshold.

If anything other than "Analog output" is selected for Output 2 (DO2), configuration of the DO2 settings will continue after the DO1 settings have been configured.

Q1 Edge Distance
0.0mm

This is displayed only when "Edge mode" is selected for Output 1 (DO1) or Output 2 (DO2).
Press the ■ key when "Edge mode" is selected for both Output 1 (DO1) and Output 2 (DO2) to switch between the Output 1 (DO1) and Output 2 (DO2) displays.

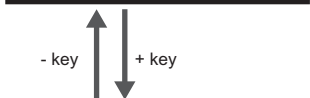

Distance(bar)

Displays the measured value as a bar graph.
The Output 1 (DO1) and Output 2 (DO2) threshold setting ranges are also displayed.

- key ↑ ↓ - key

Press and hold the ● key for 2 seconds. → Received light waveforms



Displayed in 4 segments based on distance.

+/- keys
Moves the display area.

● key
Returns to the bar graph display.

Analog value
16.802mA

Displays the current analog output value.
The value will not be displayed if analog output has not been set.

- key ↑ ↓ - key

Press and hold the ● key for 2 seconds. → Acts as a shortcut to the analog output range settings.

SET Analog Teach 4mA ● key Confirm
-49.1mm

The displayed current measured value will be set as the analog 4 mA output.

The value is set for Teach 4mA, and the display switches automatically.

SET Analog Teach 20mA ● key Confirm
150.1mm

The displayed current measured value will be set as the analog 20 mA output.

Mode
Customized

Accesses the settings for each application.

Press and hold the ● key for 2 seconds. → Each item in "Measurement" will be changed according to the specified setting. Select from "Customized," "Precision," or "Speed."

SET Mode ● key Confirm
Customized

- key ↑ ↓ - key

SET Mode ● key Confirm
Precision

- key ↑ ↓ - key

SET Mode ● key Confirm
Speed

	Sampling period	Moving average	Median filter
Customized (default setting)	200 μs	128	31
Precision	200 μs	512	31
Speed	133 μs	Off	Off

2-1-2 Recording

Displays various analysis results of sampled measurement values from start to stop.

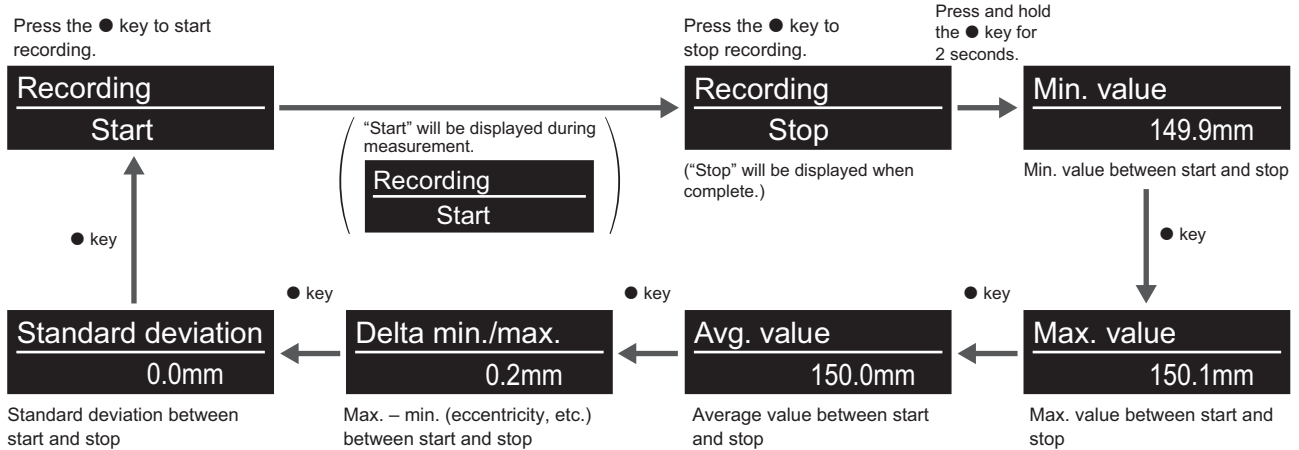

- Press the ■ key while the recording results are displayed to return to "Distance(rel.)."
- Press the - key while "Start" or "Stop" is displayed to switch to "Mode."
- Press the + key while "Start" or "Stop" is displayed to switch to "Distance(rel.)."



2-1-3 Measured Value Display (Relative Value)

<p>Distance(rel.)</p> <p>150.1mm</p>	<p>Main display (in this case, the relative value is displayed: 0 mm at the center distance of the measurement; plus a value reflecting the zero point teach). Thresholds are set and displayed as relative values.</p>
<p>(1) Press and hold the ● key for 3 seconds to display Zero point teach.</p> <p>SET Zero point teach</p> <p>Yes</p> <p>(2) Press the + or - key to select "Yes" or "Reset," and then press the ● key to confirm.</p> <p>(3) Returns to RUN mode.</p>	<p>Remarks:</p> <p>The zero-point teaching result is reflected in the analog output.</p> <p>Example:</p> <p>For an offset point of 0 mm, the output will be 12 mA or 5 V.</p> <p>Remarks:</p> <p>See "3-1-6 [A7] Measured value offset" (page 3-6).</p>

2-1-4 Measured Value Display (Absolute Value)

<div data-bbox="180 253 564 371" data-label="Text"> <p>Distance 353.06mm</p> </div>	<p>Press and hold the ■ key for 3 seconds from “Distance(rel.)” to display the distance from the sensor to the object being measured. After 30 seconds, the display will return to the “Distance(rel.)” menu. Pressing the + key will also return the display to the “Distance(rel.)” menu.</p>
<p>(1) Press and hold the ● key for 3 seconds while “Distance” is displayed to switch to the SET Output1 Mode.</p> <div data-bbox="212 638 593 757" data-label="Text"> <p>SET Zero point teach Yes</p> </div> <p>(2) Press the + or - key to select the teaching mode, and then press the ● key to execute. (3) The current value will be used for teaching. Press the ● key to execute teaching. (4) Switch to SET Output2 Mode (DO2/AO). (5) The current value will be used for teaching. Press the ● key to execute teaching.</p>	<p>Remarks: Select from “1 point,” “Zone,” “FGS2,” “No measurement,” “Light level error,” or “Edge” for Output 1 (DO1). Remarks: <ul style="list-style-type: none"> • The values displayed during teaching are relative values. • Press the ■ key to cancel teaching. • Only Teach 1 is available when “1 point” or “FGS2” is selected. Teach 2 will become available after Teach 1 is completed when “Zone” is selected (2-point setting). • Setting configuration will end if “Negative” or “Positive” is set for Teach 1 or 2 with zone teaching. Remarks: If analog output is selected beforehand for Output2 Mode (DO2/AO), the display will not switch to the Output2 Mode. Remarks: Detailed settings for each output, such as delay timers and hysteresis, can be configured from the setting mode.</p>
<div data-bbox="180 1451 564 1570" data-label="Text"> <p>Q1 Edge Distance 0.0mm</p> </div>	<p>Press the + key from “Distance(rel.)” to display (only when edge mode is set). <ul style="list-style-type: none"> • The edge measurement value will be displayed if edge mode is set for DO1 or DO2 (Output 1 or Output 2). • Set “Edge hold” to “Hold” to display the hold value, or to “OFF” to display the real calculated value. • Press the ■ key when both DO1 and DO2 (Output 1 or Output 2) are set to edge mode to switch the display between DO1 and DO2. Remarks: Not displayed when edge mode is not selected.</p>

2-1-5 Measured Value Display (Bar)

	<p>Press the + key once (twice when set to edge detection) from "Distance(rel.)" to display the measured value and the specific control output range in a bar graph.</p>
<p>(1) Press and hold the ● key for 3 seconds to view the received light waveform. The measurement range will be displayed in 4 segments. Press the + or - key to switch between the display areas.</p> 	<p>Remarks: Used to check the status of received light for the sensor. If the light level is low, set a longer sampling period or change to "Auto."</p>  <p>If ambient light other than the received light waveform is recognized, mechanically block the ambient light or use masking (see "[A11] Mask near" and "[A12] Mask far" in "[A] Measurement").</p>

2-1-6 Analog value

<div data-bbox="180 253 563 371" data-label="Text"> <p>Analog value 15.265mA</p> </div> <div data-bbox="180 394 563 512" data-label="Text"> <p>Analog value 6.793V</p> </div>	<p>Press the + key twice (3 times when set to edge mode) from "Distance(rel.)" to display the current analog value (V/mA) when Output2 Mode (DO2/AO) is set to "Analog output."</p> <p>Remarks: Not displayed if "Analog output" is not selected for Output2 Mode (DO2/AO).</p>
<p>(1) Press and hold the ● key for 3 seconds to start analog teaching.</p> <div data-bbox="212 696 595 815" data-label="Text"> <p>Teach 0V Auto -8.53mm</p> </div> <p>(2) Press the ● key to execute Teach 4mA or Teach 0V using the current value.</p> <div data-bbox="212 920 595 1039" data-label="Text"> <p>Teach 10V Auto 97.90mm</p> </div> <p>(3) Press the ● key to execute Teach 20mA or Teach 10V using the current value.</p>	<p>Remarks: Press the ■ key to cancel teaching and re-enable RUN mode.</p> <p>Remarks: Even if the analog output settings are configured to a shorter range than the original measurement range, the linearity, repeat accuracy, and resolution will not be changed.</p> <p>Remarks: Adjustment of the "Analog Teach 4mA Manual" "Analog Teach 0V Manual" "Analog Teach 20mA Manual" and "Analog Teach 10V Manual" setting values is possible in the Output 2/Analog (DO2/AO) settings.</p> <p>Remarks: This applies regardless of whether "Negative" or "Positive" is set for either side of "Analog Teach 4mA" "Analog Teach 0V" "Analog Teach 20mA" or "Analog Teach 10V"</p> <p>Remarks: Setting a range of less than 1/10 of the specified measurement range is not possible.</p>





2-1-7 Mode

<p>Mode</p> <hr/> <p>Customized</p>	<p>Press the + key 2 to 4 times (depending on the setting) from “Distance(rel.)”.</p> <p>Select from “Customized,” “Precision,” or “Speed.”</p> <p>This will enable the simple setting mode for measurement settings for each application.</p>
<p>(1) Press and hold the ● key for 3 seconds to switch to SET Mode.</p> <p>SET Mode</p> <hr/> <p>Customized</p> <p>(2) Press the + or - key to select “Customized,” “Precision,” or “Speed,” and then press the ● key to confirm.</p> <p>(3) Returns to “Mode” after confirming the setting.</p>	<p>Detailed settings for each mode</p> <ul style="list-style-type: none"> • Customized <ul style="list-style-type: none"> Applies the settings in Measurement. • Precision <ul style="list-style-type: none"> Sampling period = 200 μs Moving average = 512 Median filter = 31 • Speed <ul style="list-style-type: none"> Sampling period = 133.3 μs Moving average = 1 Median filter = Off

2-1-8 Recording

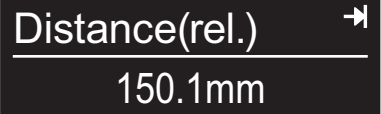
<p>Recording</p> <hr/> <p>Stop</p>	<p>Press the + key 3 to 5 times (depending on the setting) from “Distance(rel.)” to display the recording operating status.</p> <p>Start: Recording in progress. Press [●] quickly to stop recording. The display will change to “Stop.”</p> <p>Stop: Recording stopped. Press and hold [●] to display the recording results. Press [●] quickly to display the measurement results at any time.</p>
<p>(1) Press and hold the ● key after recording stops to display the minimum value during the simple measurement. Afterwards, pressing the ● key quickly will display the minimum value, maximum value, average value, maximum–minimum (difference), and then standard deviation.</p> <p>(2) “Recording start” will be displayed after the standard deviation is displayed. Start recording again if necessary.</p>	<p>Check the following between start and stop.</p> <ul style="list-style-type: none"> • Min. value • Max. value • Average value • Max. – Min. • Standard deviation

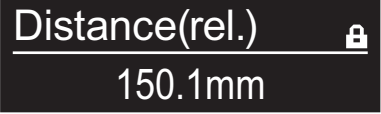
2-1-9 [Reference] Status Icons

 <p>Distance(rel.)  150.1mm</p>		<p>An arrow icon will appear in the upper-right corner of the display when the zero point teach is enabled.</p> <p>The icon will be displayed on “Distance(rel.),” “Distance(bar),” and “Analog value”.</p> <p>The arrow icon will disappear if the zero point teach is released.</p> <p>See page 2-5 for how to enable/release the zero point teach.</p>
 <p>Distance(rel.)  150.1mm</p>		<p>The lock icon will appear on the right side of the display while the keys are locked.</p> <p>The icon will be displayed in the main menu.</p> <p>If a key is pressed while the keys are locked, “LOCKED” will be displayed for 3 seconds before the display will return to the main menu.</p> <p>The lock icon will disappear if the key lock is released.</p> <ul style="list-style-type: none"> • Locking: Press the + and - keys simultaneously for at least 2 seconds. “LOCKED” will be displayed for 3 seconds before the display returns to the main menu. • Unlocking: Press the + and - keys simultaneously for at least 2 seconds. “UNLOCKED” will be displayed for 3 seconds, and then the display will return to the main menu.



3

Settings Menu

(Press the ● key at the main menu to enable the setting mode.)

This chapter explains how to use the settings menu.

3-1 [A] Measurement

Use this menu to configure measurement-related settings such as the sampling period, moving average, and median filter.

Configured settings are applied to both DO1 (Output 1) and DO2 (Output 2).

3-1-1 Basic Key Operations for Configuring Settings

■ Procedure

RUN mode

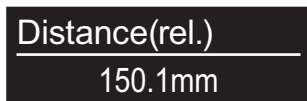

Press the ● key.

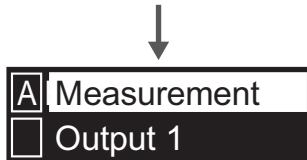

Press the + or - key to select (highlight) "Measurement."

Press the ● key to access the "Measurement" settings.

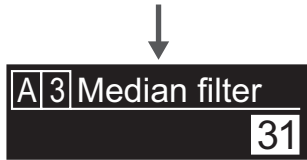

Press the + or - key to select the setting item ("Sampling period," "Median filter," etc.) to be edited.

Setting items	
[A1] Sampling period	[A12] Mask far
[A2] Moving average	[A16] Error mode
[A3] Median filter	[A17] Set clamp value
[A6] Measurement direction	[A18] Error hold time
[A7] Measured value offset	[A99] End
[A11] Mask near	

Press the ● key to confirm.



Press the + or - key to select the setting.

Press the ● key to confirm.



Press the + or - key to select the next setting item to be edited.



Press the ● key to edit the next selected setting item, and when finished, press the ● key to confirm.



After configuring all settings, press the ■ key twice to return to RUN mode.

■ Number-based changes

Measured value offset / Mask near / Mask far / Error mode / Error hold time

[A] 7 Measured value offset
0.0mm

Select one of the above setting items and press the ● key.

[A] 7 Measured value offset
+0000.0mm

The leftmost digit will be highlighted.

[A] 7 Measured value offset
+0030.0mm

Press the + or - key to edit the highlighted value.

Press the ● key to select the digit to the left.

Press the ■ key to move the highlight to the left.

After editing the rightmost digit, press the ● key to confirm the set value.

If a value that cannot be set is entered, the numerical value display will flash, and the leftmost digit will be highlighted (prompting the user to set the value again).

Press the + or - key to move to the next item to be configured.

When finished, press the ■ key twice to return to RUN mode.

3-1-2 [A1] Sampling period

Sets the time needed to perform one measurement (sampling time).

The CD2H uses automatic sensitivity compensation to ensure the optimal received light amount within a set sampling period.

When using a high-speed setting (such as 133.3 μ s), the response time becomes very fast, but the received light amount is reduced. This may prevent measurement from being possible at long distances, for black targets with minimal reflection, or for tilted targets. In such situations, set a longer sampling period or change the setting to Auto.

The response time will be slower when set to a longer sampling period, but this will allow more time for capturing light. Note that setting the sampling period longer than necessary will result in high saturation.

When set to Auto, the sampling period is always changed to the optimum value so that measurements can be performed with the optimum received light amount.

Use the received light waveform mode to check the received light amount.

- Setting value: 133.3 μ s / 150 μ s / 200 μ s / 300 μ s / 500 μ s / 1 ms / 2 ms / 5 ms / AUTO
- Auto: The sampling period is automatically adjusted to ensure the fastest sampling time according to the received light amount from the target.
- Default value: 200 μ s

3-1-3 [A2] Moving average

Performs averaging for the measured values.

The process is performed on median-filtered results.

This results in smoother changes in measured values, but processing the measured value takes longer as more measurements are performed.

During startup or alarm recovery, the moving average is performed using previously accumulated values until the specified number of measured values have been accumulated.

- 1/4/8/16/32/64/128/256/512 [Unit: No. of measurements (count)]
- Default value: 128

Example: 4-count averaging

As shown below, the average of the specified measurement count is output as the measured value.

Measurement count	1	2	3	4	5	6	7	8
Measured value	1.9	1.8	2.0	2.1	2.0	2.2	2.5	2.0

Filtering range and 1st result 1.95

Filtering range and 2nd result 1.975

Filtering range and 3rd result 2.075

Filtering range and 4th result 2.2

Filtering range and 5th result 2.175

* Control output response time according to sampling period and moving average setting

Unit: ms

		Moving average (count)								
		1	4	8	16	32	64	128	256	512
Sampling period	133.3 μ s	0.533	0.933	1.466	2.532	4.665	8.931	17.462	34.524	68.649
	150 μ s	0.6	1.05	1.65	2.85	5.25	10.05	19.65	38.85	77.25
	200 μ s	0.8	1.4	2.2	3.8	7	13.4	26.2	51.8	103
	300 μ s	1.2	2.1	3.3	5.7	10.5	20.1	39.3	77.7	154.5
	500 μ s	2	3.5	5.5	9.5	17.5	33.5	65.5	129.5	257.5
	1 ms	4	7	11	19	35	67	131	259	515
	2 ms	8	14	22	38	70	134	262	518	1030
	5 ms	20	35	55	95	175	335	655	1295	2575

3-1-4 [A3] Median filter

Cuts off sudden changes in measured values to help reduce variations. The median value of the measured values within the set measurement count is used as the definite value.

Using this in combination with the moving average should help stabilize measurement.

- Off: Median filtering is not used.
- 3/7/15/31: Specifies the count over which median filtering should be applied.
- Default value: 31

Example: Specifying median filtering for every 7 measurements:

Measurement count	1	2	3	4	5	6	7	8	9	10	
Measured value	1.9	1.8	2.0	2.1	2.0	2.2	2.5	2.0	1.8	2.1	
Filtering range and 1st result	← 2.0 →										
Filtering range and 2nd result		← 2.0 →									
Filtering range and 3rd result			← 2.0 →								

The following is the result of sorting measurements in the 1st filter range in ascending order.

In this situation, the center (4th) value of "2.0" is output as the measured value.

Unsorted	1.9	1.8	2.0	2.1	2.0	2.2	2.5
Sorted	1.8	1.9	2.0	2.0	2.1	2.2	2.5

3-1-5 [A6] Measurement direction

Sets whether to increase or decrease the height of the measured value with 0 mm as the center of the measurement range.

This setting applies to measured values (relative) and threshold settings.

- Default value: Positive

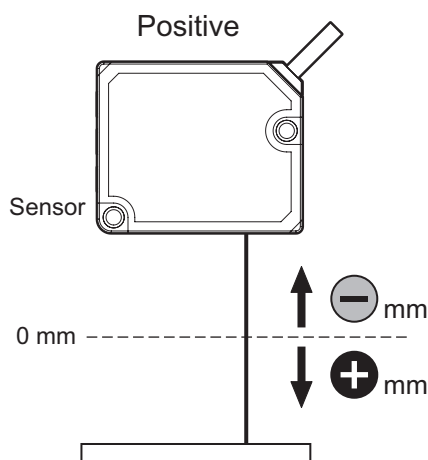

Measured values will increase as the object moves farther away from the sensor.

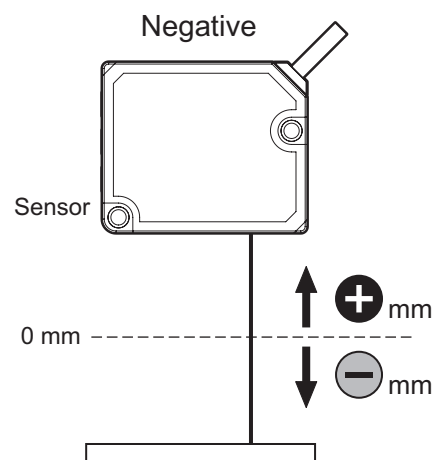

Measured values will increase as the object moves closer to the sensor.

3-1-6 [A7] Measured value offset

Stores the offset amount so that the measured value (relative) becomes zero during offset operation.

Resetting the offset will set the offset value to 0 (zero).

The offset value will be updated during each offset operation.

Offset values can also be entered manually as desired.

* The measured value (relative) becomes 0 (zero) at the center of measurement range for each sensor by default (350 mm for the CD2H-350).

* The control output thresholds will also apply during offset operation.

* The analog output range is also offset during offset operation.

The position at which offset is performed becomes the analog output center value.

- When 4 to 20 mA is selected, the offset position becomes 12 mA.
- When 0 to 10 V is selected, the offset position becomes 5 V.

Example 1: If the CD2H-350 indicates a measured value (relative) of 150.0 mm (absolute value: 500.0 mm) and offset adjustment is performed, 150.0 mm will be stored as the analog current output and [A7] measured value offset.

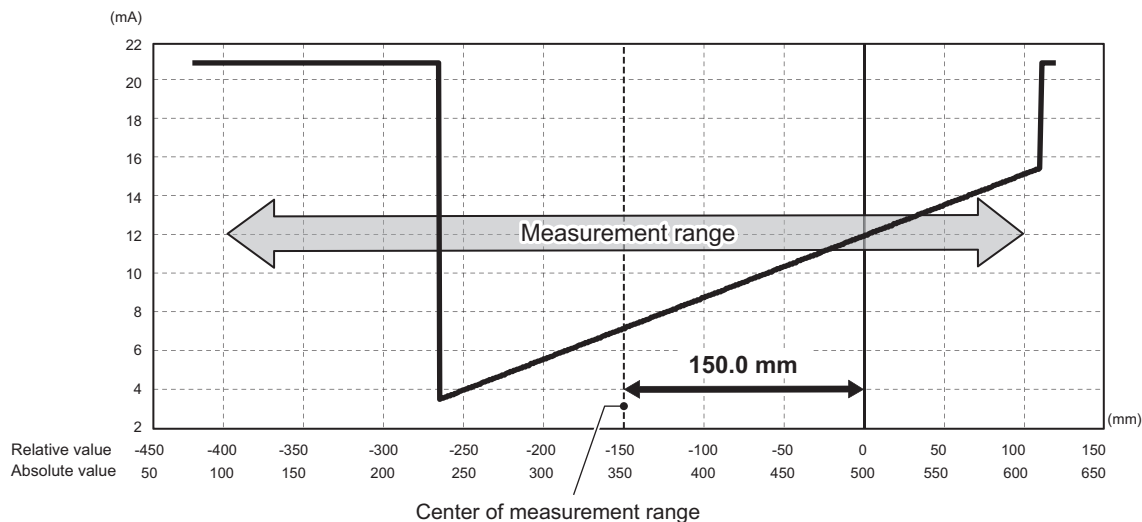

Example 2: If the CD2H-350 indicates a measured value (relative) of -200.0 mm (absolute value: 150.0 mm) and offset adjustment is performed, -200.0 mm will be stored as the [A7] measured value offset.

3-1-7 [A8] Span Teach, Auto

This function uses an actual measured object to adjust the measured value. The measured distance between the IO-Link device and the display can be adjusted with two points (excluding analog output*).

This function is primarily used when:

- The CD2H is installed at an angle to the measured object but the measured value should be the same as when the CD2H is installed with a vertical orientation.
 - The actual measured object will be used to adjust for errors arising from changes in the measured object surface conditions (glossy/not glossy, smooth/rough, bright colors/dark colors, etc.).
- * See “3-3-3 [C31] Analog Teach 4mA Auto / [C32] Analog Teach 20mA Auto” on page 3-30 to “3-3-6 [C38] Analog Teach 0V Manual / [C39] Analog Teach 10V Manual” on page 3-31 for details on how to set the adjustment of the analog output.

Usage example)

As shown in the following graph, when the 1st point measured value (Point A) is displayed as 10.5 mm and the 2nd point measured value (Point B) is displayed as 19.8 mm, the 1st point measured value can be displayed and output as 10.0 mm (Point C) and the 2nd point measured value can be displayed and output as 20.0 mm. However, it is not possible to make large adjustments such as changing the 1st point measured value to 1000.0 mm and the 2nd point measured value to 1020.0 mm.

See the section “Ranges in which adjustment cannot be set” below for details on ranges in which adjustment cannot be set.

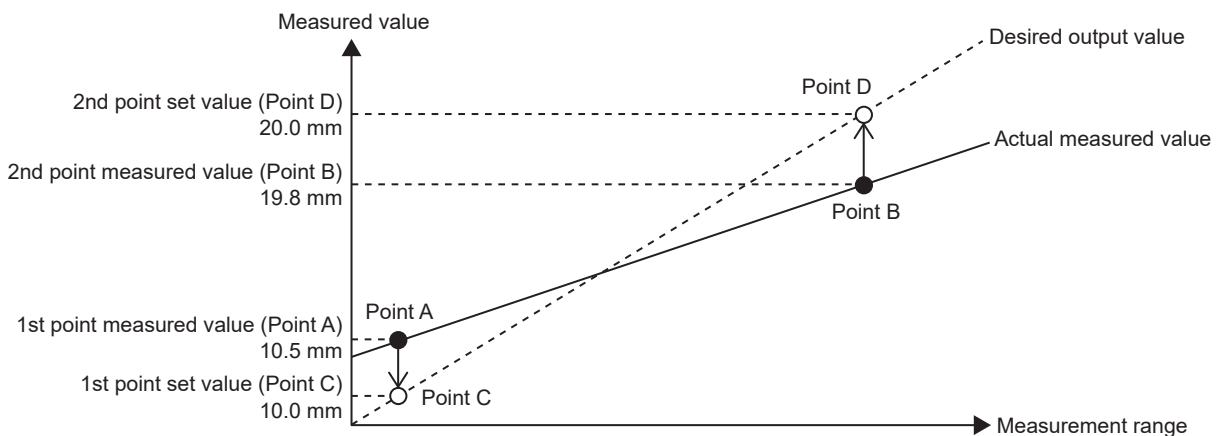

Ranges in which adjustment cannot be set

- The adjustment cannot be set if the span value exceeds ± 2 based on the following calculation.

$$\text{Span value} = (\text{Point D} - \text{Point C}) \div (\text{Point B} - \text{Point A})$$

- The adjustment cannot be set if the shift value exceeds the range for the model based on the following calculation.

$$\text{Shift value} = (\text{Point A} \times \text{span value}) - \text{Point C}$$

CD2H-30x:	± 5 mm
CD2H-50x:	± 10 mm
CD2H-130x:	± 70 mm
CD2H-245x:	± 175 mm
CD2H-350x:	± 250 mm
CD2H-700x:	± 500 mm

The setup procedure is as follows. Measure an actual measured object, and make adjustments on the basis of the measured value.

(1) Display setting item [A8] Span Teach, Auto.

↓

<Teach the 1st point measured value>

(2) Place the measured object at the position of the 1st point, where adjustment will be performed, and press the ● key to display the 1st point measured value (Point A).

* The relative distance with no measured value adjustment or offset applied is displayed.

* The 1st point measured value is taught with the measured value (the value on the top row of the display) when the ● key is pressed.

↓

<Enter the 1st point set value>

(3) Press the ● key, and then enter the 1st point set value (Point C) based on the 1st point measured value (Point A).

Pressing the ● key moves the cursor between digits, so select the digit to change, and then change it with the + and – keys. If an incorrect value is entered, press the ■ key to return to the previous digit and enter the value again.

Enter subsequent values in the same manner.

(4) After changing the value of the final digit on the right side, press the ● key to confirm the 1st point set value.

↓

<Teach the 2nd point measured value>

(5) After the 1st point set value is confirmed, the 2nd point measured value (Point B) is displayed. (The relative distance with no measured value adjustment or offset applied is displayed.)

* The relative distance with no measured value adjustment or offset applied is displayed.

(6) Place the measured object at the position of the 2nd point, where adjustment will be performed, and press the ● key to display the 2nd point measured value (Point B).

* The 2nd point measured value is taught with the measured value (the value on the top row of the display) when the ● key is pressed.

↓

<Enter the 2nd point set value>

(7) Enter the 2nd point set value (Point D) based on the 2nd point measured value (Point B).

(8) After changing the value of the final digit on the right side, press the ● key to confirm the 2nd point set value.

(9) The menu returns to [A8] Span Teach, Auto. This completes the setup.

MEMO

- There are no restrictions on the size of the values entered for the 1st and 2nd points, so the distance of the 1st point can be set to a larger value than the distance of the 2nd point.
- After measured value adjustment, if the measured value offset is not zero, an arrow icon will appear on the Distance(rel.) display.



- To initialize (release) [A8] Span Teach, Auto, use [E4] Span Teach Reset (page 3-47).
- * If initialization is performed with [E4] Span Teach Reset, [A9] Span Teach, Manual will also be initialized (released).
- * If measured value adjustment is initialized, the measured value offset will also be initialized (released).

3-1-8 [A9] Span Teach, Manual

In this adjustment method, the measured values of the 1st and 2nd points are checked, and then the set values for these points are entered manually. In the previous section, [A8] Span Teach, Auto, the key on the sensor is pressed to obtain the measured value to use as the reference, but pressing this key may result in a slight sensor misalignment, leading to a corresponding deviation in the measured value.

With Span Teach, Manual (described here), the measured and set values are entered directly, allowing for adjustment with no deviation.

- * Measured values with no offset or measured value adjustment applied must be entered for the 1st point measured value and 2nd point measured value.
- * If an offset has been applied, press and hold the ● key, and then select “Reset” for SET Zero point teach.

The setup procedure is as follows.

(1) Display setting item [A9] Span Teach, Manual.

↓

<Enter the 1st point measured value>

(2) Press the ● key to display “+000.00 mm” for the 1st point measured value (the decimal point position depends on the model). Enter the 1st point measured value (Point A), which will be the reference for the adjustment.

Pressing the ● key moves the cursor between digits, so select the digit to change, and then change it with the + and – keys. If an incorrect value is entered, press the ■ key to return to the previous digit and enter the value again.

Enter subsequent values in the same manner.

- (3) After changing the value of the final digit on the right side, press the ● key to confirm the 1st point measured value.
- (4) After the 1st point measured value is confirmed, "+000.00 mm" is displayed for the 1st point set value (the decimal point position depends on the model).

↓

<Enter the 1st point set value>

- (5) Enter the set value (Point C).
- (6) After changing the value of the final digit on the right side, press the ● key to confirm the 1st point set value.
- (7) After the 1st point set value is confirmed, "+000.00 mm" is displayed for the 2nd point measured value.

↓

<Enter the 2nd point measured value>

- (8) Enter the distance to the 2nd point, which will be the reference from which adjustment is performed (Point B).

- (9) After changing the value of the final digit on the right side, press the ● key to confirm the 2nd point measured value.

- (10) After the 2nd point measured value is confirmed, "+000.00 mm" is displayed for the 2nd point set value.

↓

<Enter the 2nd point set value>

- (11) Enter the set value (Point D).
- (12) After changing the value of the final digit on the right side, press the ● key to confirm the 2nd point set value.
- (13) The menu returns to [A9] Span Teach, Manual. This completes the setup.

* See "[A8] Span Teach, Auto" for details on Point A to Point D and on ranges in which adjustment cannot be set.

MEMO

- There are no restrictions on the size of the values entered for the 1st and 2nd points, so the distance of the 1st point can be set to a larger value than the distance of the 2nd point.
- After measured value adjustment, if the measured value offset is not zero, an arrow icon will appear on the Distance(rel.) display.



- To initialize (release) [A9] Span Teach, Manual, use [E4] Span Teach Reset (page 3-47).
 - * If initialization is performed with [E4] Span Teach Reset, [A8] Span Teach, Auto will also be initialized (released).
 - * If measured value adjustment is initialized, the measured value offset will also be initialized (released).
-

3-1-9 [A11] Mask near / [A12] Mask far

Sets a masked range where measurement will not be performed within the measurement range.

This setting can be used to ignore surrounding ambient light or measured objects that are not measurement targets.

It is recommended to use the received light waveform mode when using this setting.

For near-side measurements, the mask will be applied between the near-side measurement limit and the setting value.

For far-side measurements, the mask will be applied between the far-side measurement limit and the setting value.

3-1-10 [A16] Error mode

Sets the behavior when an alarm occurs (when no measurement data is available or when measurement is not possible).

- Default value: Clamp value

● Clamp value

The measured value becomes the set clamp value while the alarm is detected.

This setting specifies how the measured value should be displayed when measurement is not possible.

The specified value is displayed (set clamp value).

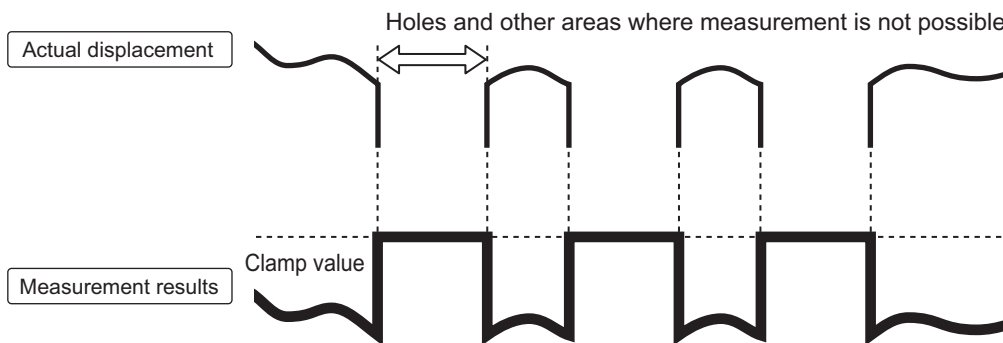

● Hold last value

The measured value immediately before the alarm occurred is held. This value is held until measurement is once again possible.

The value immediately before the alarm occurred is held.

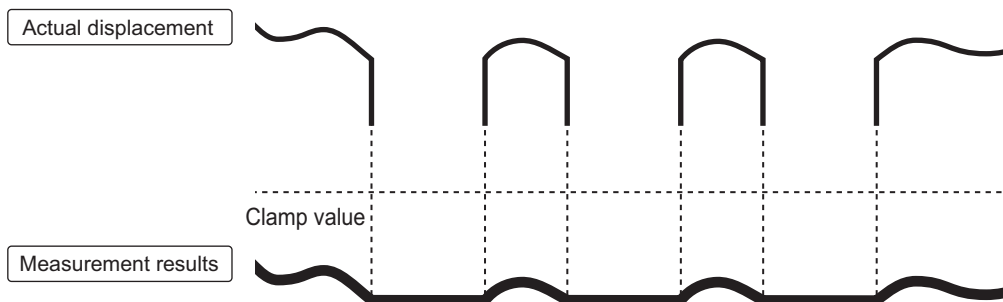

● Hold last value + timer

Performs a "Clamp value" operation after the "Hold last value" operation is performed for the specified time.

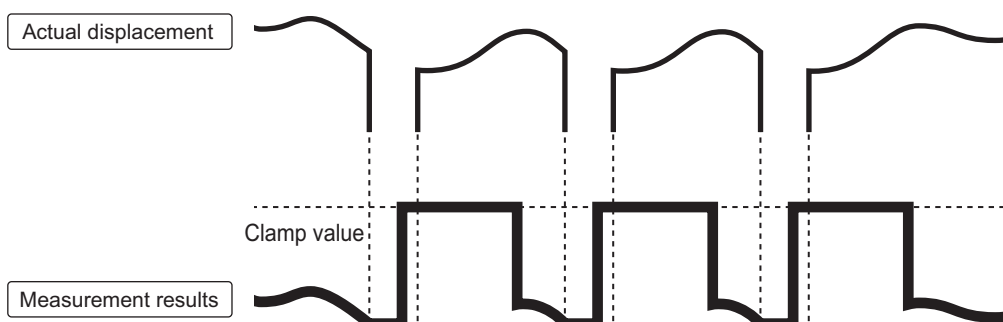

3-1-11 [A17] Set clamp value

Sets the value to be displayed when an alarm occurs (when no measurement data is available or when measurement is not possible).

The value specified here will be displayed when “Clamp value” is selected.

- Setting range: -2000.0 to +2000.0 mm
- Default value: 2000.0 mm

3-1-12 [A18] Error hold time

Becomes available when “Hold last value + timer” is selected for the set clamp value. The length of time the value immediately before the alarm occurred is held can be set in units of 1 ms.

- Setting range: 1 to 100,000 ms
- Default value: 1 ms

3-2 [B] Output 1 (DO1) Settings

Use this setting to configure Output 1 settings, such as the output mode, threshold setting, and delay timer.

3-2-1 Key Operations for Configuring Settings

■ Procedure

RUN mode

Distance(rel.)
150.1mm

Press the ● key.

↓
A Measurement
B Output 1

Press the + or - key to highlight "Output 1."

Press the ● key to access the "Output 1" settings.

↓
B 1 Output1 Mode
DO1 Zone

Press the ● key to edit the output mode settings. ("DO1 1 point," etc. will be highlighted.)

Press the + or - key to select the desired output mode, and then press the ● key to confirm. (Select from "1 point," "Zone," "FGS2," "No measurement," "Light level error," or "Edge.")

↓
B 8 DO1 Teach 1 Manual
-32.2mm

Press the + or - key to select the setting item to be edited, such as "Teach 1 Auto," "Teach 1 Manual," or "Output mode."

Press the ● key to edit the selected setting item, and when finished, press the ● key to confirm.

↓
B 16 DO1 Output mode
Near On

Press the + or - key to select the next setting item to be edited.

Press the ● key to edit the selected setting item, and when finished, press the ● key to confirm.

↓
After configuring all settings, press the ■ key twice to return to RUN mode.

■ Number-based changes

DO1 Teach 1 Manual / DO1 Teach 2 Manual / DO1 Edge Max. / DO1 Edge Min. / DO1 Cycle offset / DO1 Timer set / DO1 Hysteresis / DO1 Tolerance

[B] 8 DO1 Teach 1 Manual
-32.2mm

Select one of the above settings and press the ● key.

[B] 18 DO1 Timer set
1ms



[B] 8 DO1 Teach 1 Manual
-003².2mm

The leftmost digit will be highlighted.

Press the + or - key to edit the highlighted value.

Press the ● key to select the digit to the left.

[B] 18 DO1 Timer set
000¹0ms



After editing the rightmost digit, press the ● key to confirm the set value.

If a value that cannot be set is entered, the numerical value display will flash, and the leftmost digit will be highlighted (prompting the user to set the value again).



Press the + or - key to move to the next item to be configured.



When finished, press the ■ key twice to return to RUN mode.

3-2-2 [B1] Output1 Mode

Sets how detection should be performed for the measured value.

This setting defines the relationship between the threshold or hysteresis and output.

■ DO1 1 point

Output 1 turns off at a position at a distance equivalent to hysteresis from the position set through teaching or by the threshold.

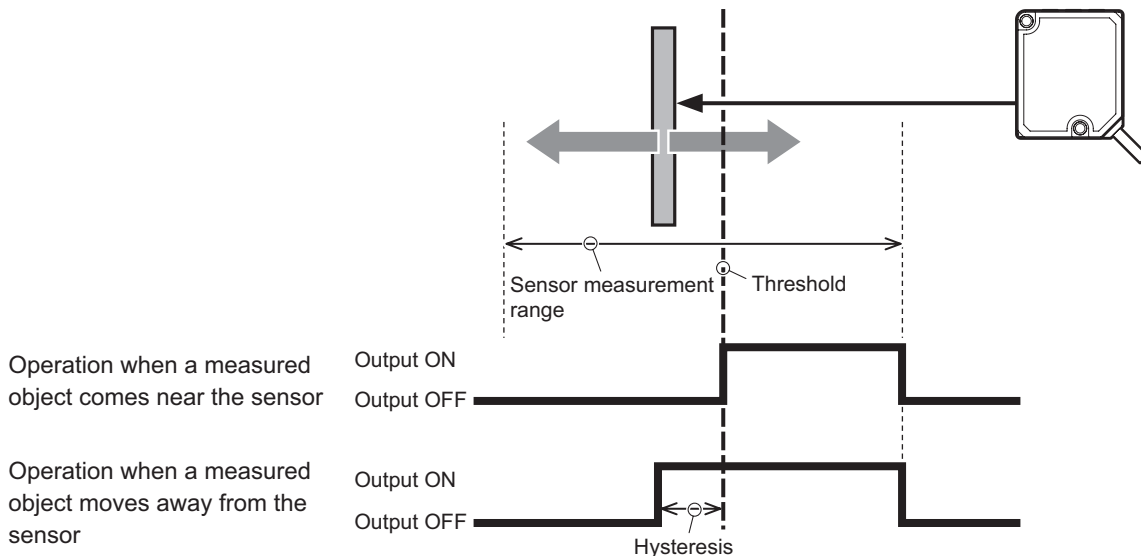

* See page 3-27 for more information on hysteresis.

■ DO1 Zone

Position set through Teach 1 Auto (near-side measurement) or by Teach 1 Manual.

Position set through Teach 2 Auto (far-side measurement) or by Teach 2 Manual.

Output 1 turns on between these two points. Operation will be suspended for the set hysteresis amount during operation with output turned off.

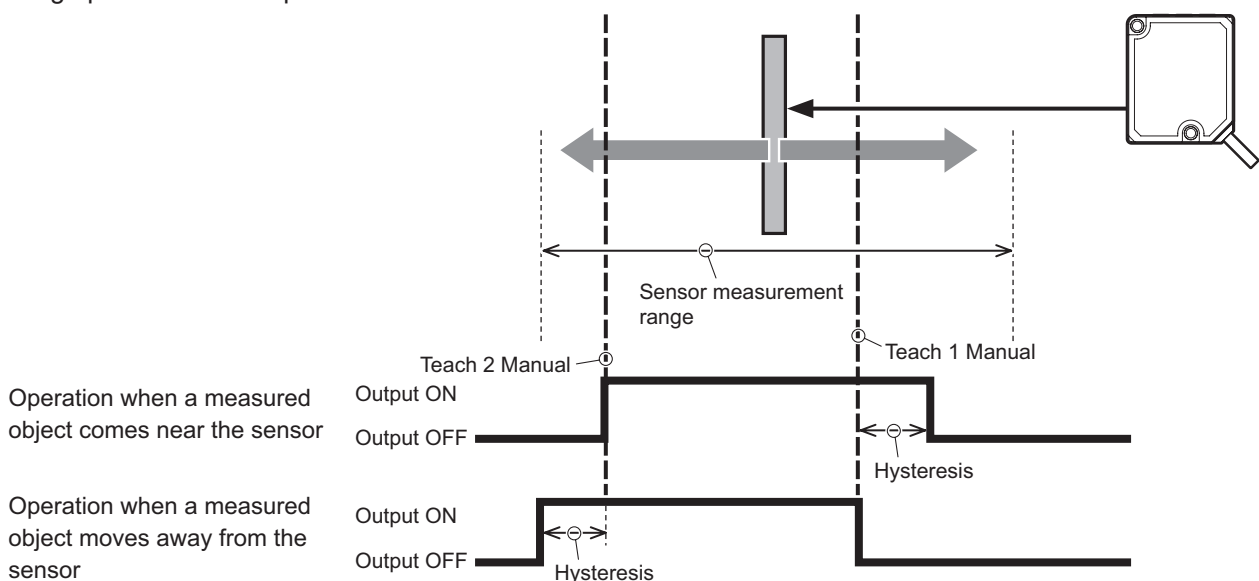

* See page 3-27 for more information on hysteresis.

■ DO1 FGS2

DO1 Control Output 1 turns off within an area equivalent to the tolerance set centered on the Teach 1 Manual position (when “Near On” is selected for the output mode).

Operation will be suspended for the set hysteresis amount during operation with output turned off.

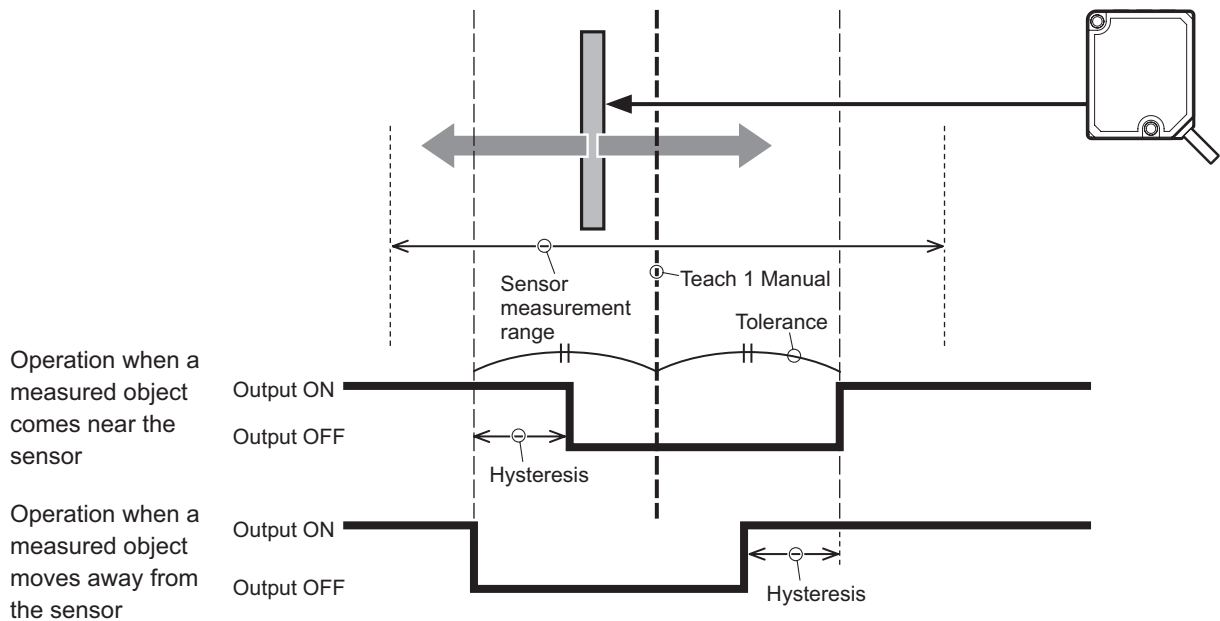

* See page 3-27 for more information on hysteresis.

■ DO1 No measurement

Output 1 turns on when an alarm occurs (when outside the measurement range or when measurement is not possible).

■ DO1 Light level error

Sets the output to use if a light level error occurs.

Under normal operation, the automatic sensitivity function is enabled, and the display shows a value of about 3000.

If an object is placed in the measurement range and the light level becomes about 1300, measures to counter the low light level will be necessary, such as making the sampling period longer.

- Default threshold for light level error: 1700

■ DO1 Edge

This function is used in the following situations.

- When sudden changes are detected
- When the reference position changes in waves, making setting thresholds difficult

Example: • Booklet counting

- Peak/valley edge mode

● Edge measurement value

The difference between the current measured value and the measured value before the cycle offset count becomes the edge measurement value.

The edge measurement value can be displayed in real-time or as a held value.

The edge measurement value will be held if the edge measurement value falls within the range between the edge lower limit and edge upper limit.

Afterward, the held edge measurement value will be updated to the value when the edge measurement value goes beyond this range and then falls back into this range.

- Output when the edge measurement value falls within the range between the “Edge Min. (edge lower limit)” and “Edge Max. (edge upper limit).” (“Edge Min.” and “Edge Max.” are set according to the change amount. Plus and minus signs are not used.)
- The detection direction is configured as follows. (These settings are similar to rising edge or falling edge detection.)

Detects when the measured value changes positively: Positive direction

Detects when the measured value changes negatively: Negative direction

Detects when the measured value changes either positively or negatively: Both

* The above directions are reversed if “Measurement direction” is changed in “Measurement.”

Overview diagram of edge mode

Measured object
(example)

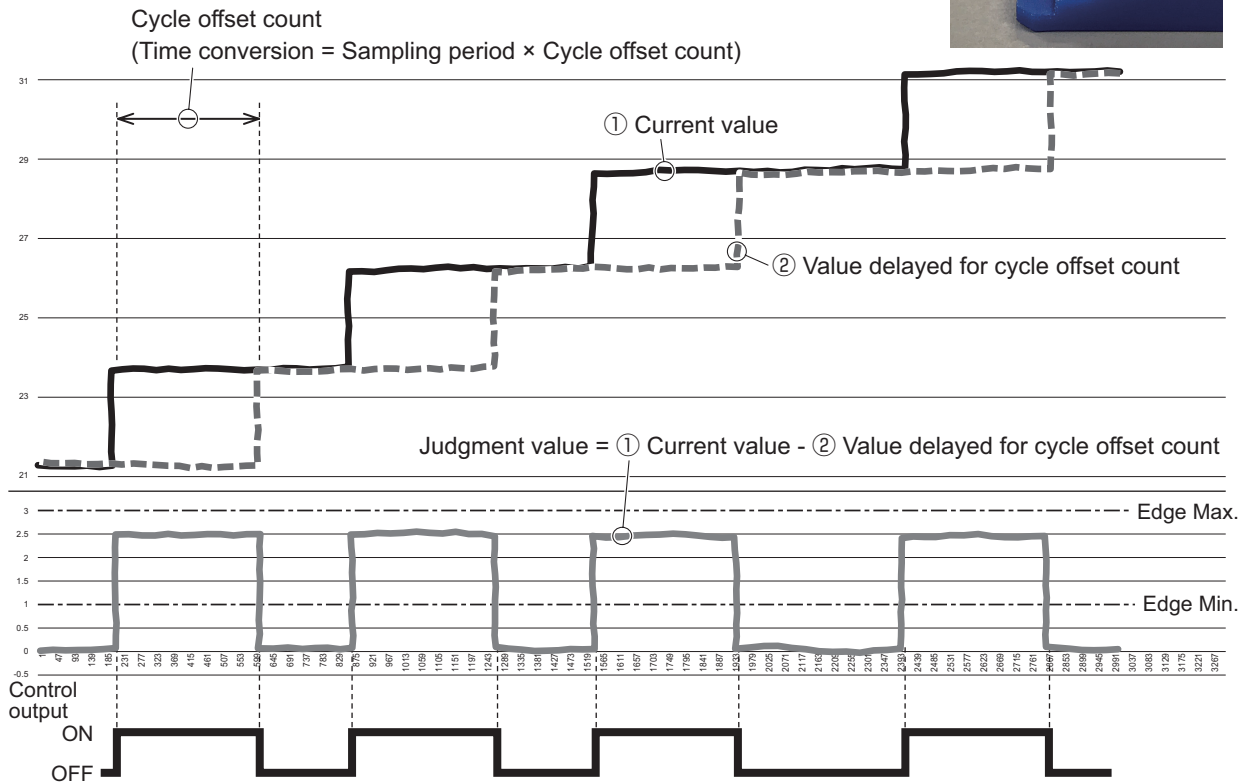
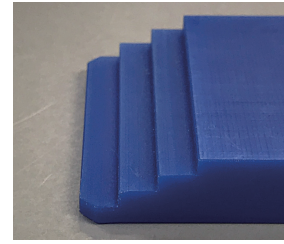

Edge mode is largely influenced by the sampling period, moving average, and median filter settings.

- Sampling period: At least 20 sampling cycles are required between the edge intervals being detected.
- Moving average: This should be set as low as possible. (A setting of “1” is best.)

If the moving average results in the edges becoming unclear, the amount of change will be small, and stable detection will not be possible.

- Median filter: Set to “Off.”

If the median value is traced, the timing of the edge shape will be off.

Booklet count settings example

Example detection conditions

- Line speed = Approx. 100 mm/sec
- Sampling period = 0.5 ms
- Moving average = 1 count
- Median filter = Off
- Narrowest edge spacing = Approx. 5 mm
- Smallest gap = Approx. 2 mm

Measured object (booklet)

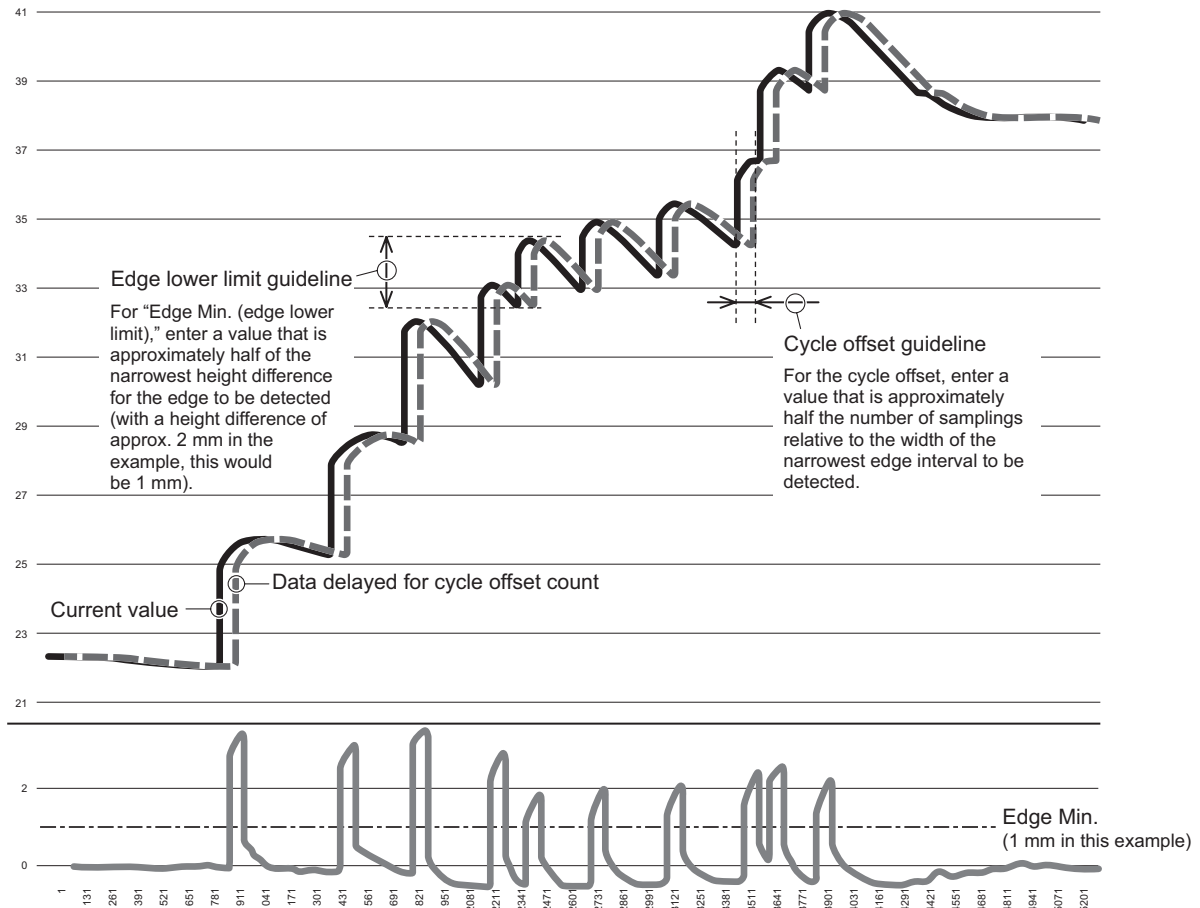

Finding the cycle offset in the above example

$$\boxed{\text{Narrowest width (5 mm)}} \div 2 \div \boxed{\text{Movement speed (100 mm/s)}} \div \boxed{\text{Sampling period (0.5 ms)}} = 5 \div 2 \div 100 \div 0.0005 \text{ (s)} = 50 \text{ (count)}$$

Edge hold behavior for example edge measurement values

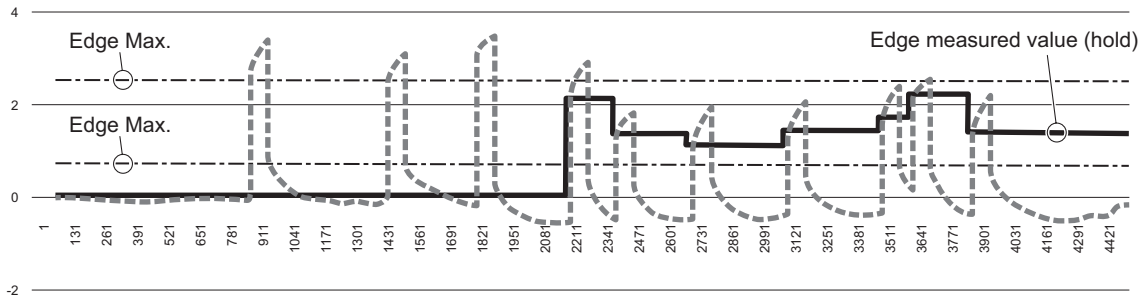

No hold operation is performed for edge measurement values (hold off), and values are displayed as a gray dashed line.

Variations in the actual conveyor surface level will likely affect the edge measurement value.

We strongly recommend conducting trial operation under various circumstances when considering using this function.

3-2-3 [B6] DO1 Teach 1 Auto / [B7] DO1 Teach 2 Auto

■ 1 point

The current value is displayed for Teach 1 Auto, and pressing the ● key twice writes the current value to Teach 1 Manual. Teach 2 Auto is not displayed.

■ Zone

The current value is displayed for Teach 1 Auto, and pressing the ● key twice writes the current value to Teach 1 Manual. After the next measured object is transferred, the current value is displayed for Teach 2 Auto, and pressing the ● key twice writes the current value to Teach 2 Manual.

* Supplementary information: This setting can be configured when either (Teach 1 Auto/Teach 1 Manual) < (Teach 2 Auto/Teach 2 Manual) or (Teach 1 Auto/Teach 1 Manual) > (Teach 2 Auto/Teach 2 Manual) applies.

■ FGS2

The current value is displayed for Teach 1 Auto, and pressing the ● key twice writes the value to Teach 1 Manual. Teach 2 Auto is not displayed.

■ No measurement

Teach 1 Auto and Teach 2 Auto are not displayed.

■ Light level error

The current value is displayed for Teach 1 Auto, and pressing the ● key twice writes the value to Teach 1 Manual. Teach 2 Auto is not displayed.

■ Edge

Teach 1 Auto and Teach 2 Auto are not displayed.

3-2-4 [B8] DO1 Teach 1 Manual / [B9] DO1 Teach 2 Manual

■ 1 point

Edits and writes the value written using Teach 1 Auto or the existing setting value.

■ Zone

Edits and writes the value written using Teach 1 Auto or Teach 2 Auto or the existing setting value.

* Supplementary information: This setting can be configured when either (Teach 1 Auto/Teach 1 Manual) < (Teach 2 Auto/Teach 2 Manual) or (Teach 1 Auto/Teach 1 Manual) > (Teach 2 Auto/Teach 2 Manual) applies.

■ FGS2

Edits and writes the value written using Teach 1 Auto or the existing setting value.

■ No measurement

Teach 1 Manual and Teach 2 Manual are not displayed.

■ Light level error

Edits and writes the value written using Teach 1 Auto or the existing setting value.

■ Edge

Teach 1 Manual and Teach 2 Manual are not displayed.

3-2-5 [B11] DO1 Edge Min.

Enter the lower limit of the measured value (the difference between the current value and the measured value before the cycle offset count) for edge mode. This is output when the measured value falls within the upper and lower limits.

This is displayed only when edge mode is selected.

3-2-6 [B12] DO1 Edge Max.

Enter the upper limit of the measured value (the difference between the current value and the measured value before the cycle offset count) for edge mode. This is output when the measured value falls within the upper and lower limits.

This is displayed only when edge mode is selected.

3-2-7 [B13] DO1 Switch direction

Sets the change direction of the measured value for edge mode. Changing the measurement direction will reverse this setting.

- Positive: Detection is performed only when the measured value changes positively (rising edge detection).
- Negative: Detection is performed only when the measured value changes negatively (falling edge detection).
- Both (rising and falling): Detection is performed on both the rising and falling edge.

3-2-8 [B14] DO1 Cycle offset

Sets which previous measured value (counted from the current value) to use for comparison in edge mode.
 $\text{Sampling period} \times \text{Cycle offset} = \text{Offset time}$ (how much time has passed since the previous measured value used for comparison)

3-2-9 [B16] DO1 Output mode

The following figure shows the changes in on/off statuses for each setting.

Sets the output operation polarity. This function is similar to light on/dark on switching.

- Near On: Turns the output on at the side nearest the threshold or within the range of Teach 1 Manual and Teach 2 Manual.
- Far On: Turns the output off at the side nearest the threshold or within the range of Teach 1 Manual and Teach 2 Manual.

■ 1 point

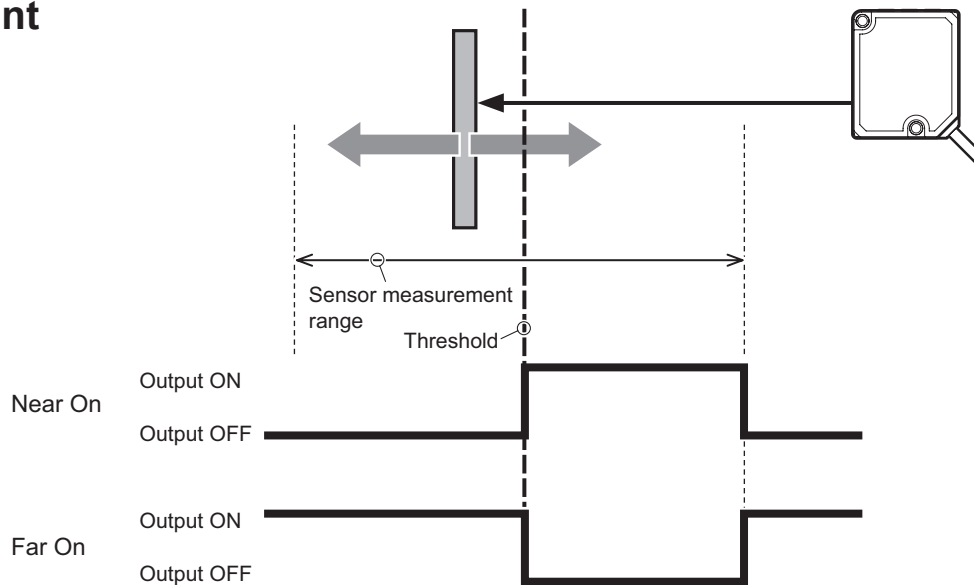

■ Zone

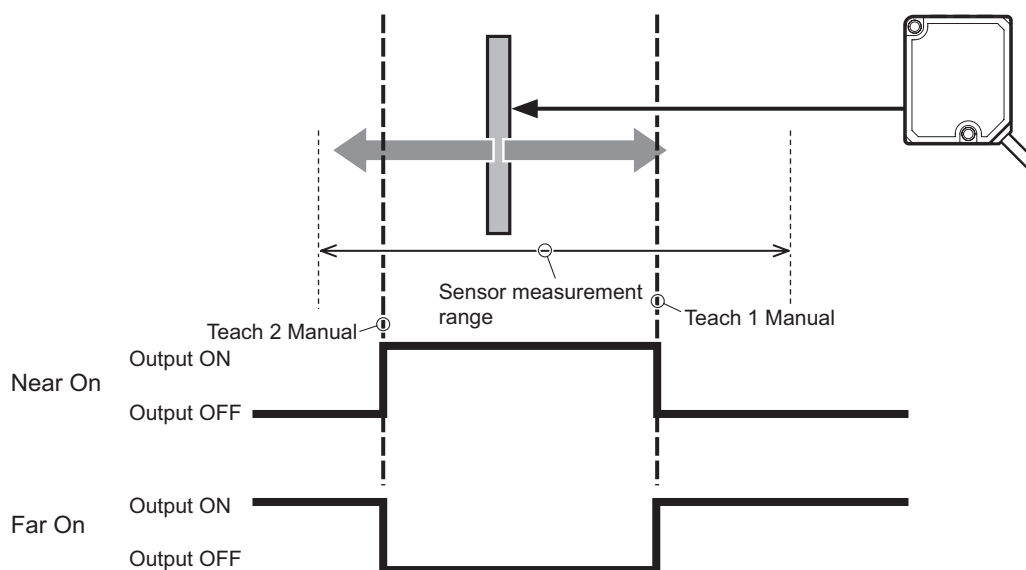

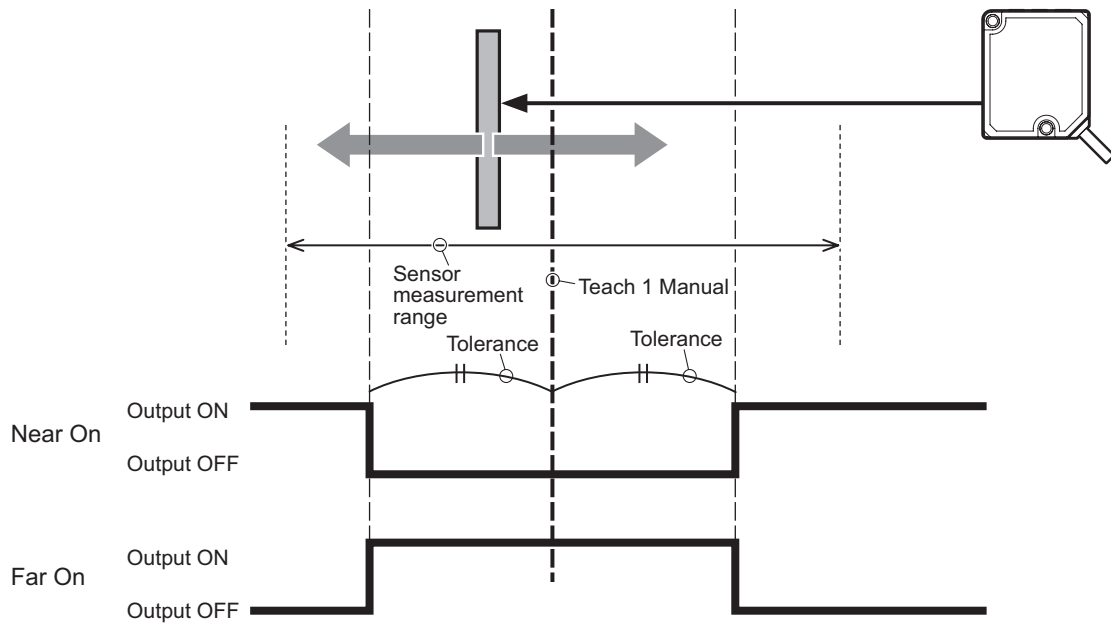

3-2-10 [B17] DO1 Delay timer

Selects the delay function.

- Off: The control output is turned on when the judgment is turned on.
- On delay: The output turns on after the specified time delay after the judgment is turned on. This setting is useful when trying to prevent chattering that causes on/off switching to be repeated at high speed.
- Off delay: The output turns off after the specified time delay after the judgment is turned off. This setting is useful when the ON time is very short and the input device cannot respond effectively.
- On/off delay: Mixed On delay and Off delay operation is performed.
- One shot: The control output is turned on for the specified time and then turned off.

3-2-11 [B18] DO1 Timer set

Sets the delay time. For one-shot operation, this setting becomes the ON time instead of the delay time.

* Individual delay times cannot be set for On/Off delay operation.

* Turn off the delay function to set a delay time of 0 ms.

Setting range: 1 to 30,000 ms

■ Timing chart: Difference in on/off operation according to the delay set for measured value changes

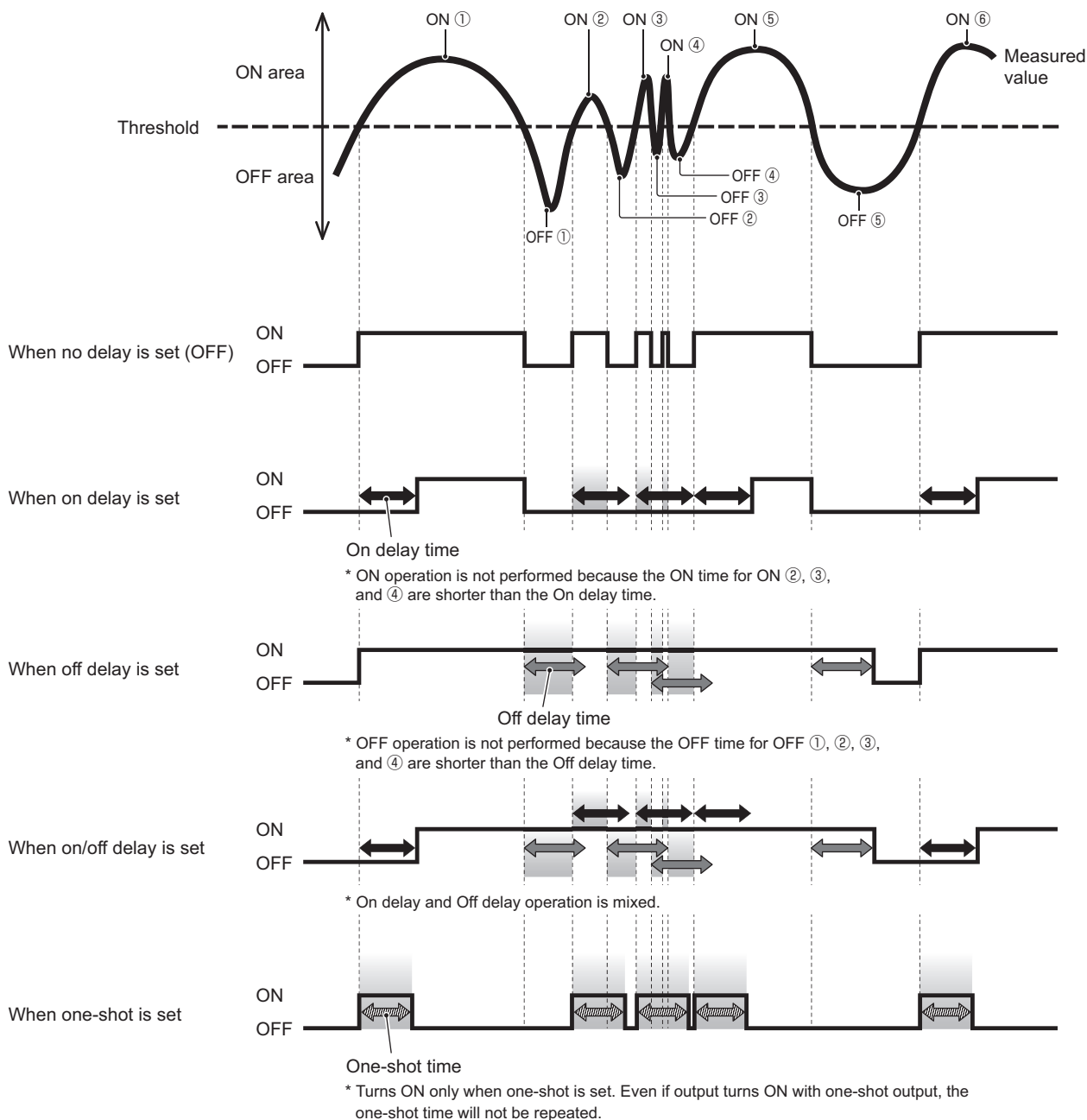

3-2-12 [B19] DO1 Hysteresis

When the measured value approaches the threshold value (upper or lower), the control output may turn on/off repeatedly (chattering).

This condition can be prevented by providing a range of values at which the output should be turned on and then off after the threshold is exceeded.

This range is referred to as “hysteresis.” The hysteresis can be set as desired with the CD2H.

This will result in operation being suspended for the hysteresis amount when the control output turns off.

The output mode (1-point teaching, zone teaching, FGS2) will determine how hysteresis will be applied.

See the section on the output mode (which outlines the relationship between thresholds/hysteresis and output) in page 3-16 for more information.

3-2-13 [B20] DO1 Tolerance

This setting is only available when set to FGS2.

The setting range is the +/- tolerance range centered on the teaching point.

This setting can be used to change the setting range whenever the master or reference position changes.

3-2-14 [B21] DO1 Edge hold

This setting is only available when set to edge mode.

When hold operation is selected, the value when measurement enters the set upper and lower edge limit range.

3-3 [C] Output 2/Analog Output (DO2/AO) Settings

Use this setting to configure Output 2 settings such as analog output, control output, threshold setting, and delay timer.

3-3-1 Key Operations for Configuring Settings

■ Procedure

RUN mode

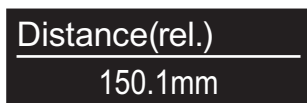

Press the ● key.

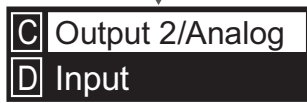
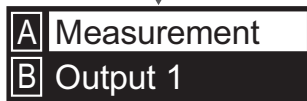

Press the + or - key to highlight "Output 2/Analog."
Press the ● key to access the "Output 2/Analog" settings.

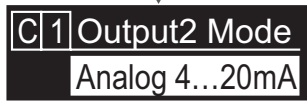
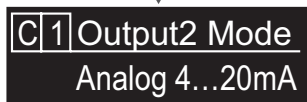

Press the ● key to edit output mode settings. ("Analog 4...20mA" or other settings will be highlighted.)
Press the + or - key to select the desired output mode, and then press the ● key to confirm.

The selections available for Output 2/Analog output (DO2/AO) are listed below.

- Analog 4...20mA Outputs the measured value as an analog current of 4 to 20 mA.
- Analog 0...10V Outputs the measured value as an analog voltage of 0 to 10 V.
- DO2 1 point Sets the control output threshold (1 point). See page 3-16 for more information.
- DO2 Zone Sets the control output upper and lower limit thresholds (2 points). See page 3-16 for more information.
- DO2 FGS2 Determines the tolerance range (+/-) centered on the position of Teach 1 Manual. See page 3-17 for more information.
- DO2 not equal to Q1 Inverts the output of Output 1 (DO1).
- DO2 No measurement Output when measurement is not possible. See page 3-17 for more information.
- DO2 Light level error Output when the received light level falls below the threshold. See page 3-17 for more information.
- DO2 Edge Used for identifying height differences. See page 3-18 for more information.
- Off Disables use of Output 2/Analog output (DO2/AO).

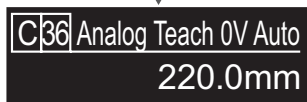

C36 Analog Teach 0V Auto
220.0mm

Press the + or - key to select the setting item to be edited, such as "Analog Teach 0V Auto," or "Analog Teach 10V Auto."

Press the ● key to edit the selected setting item, and when finished, press the ● key to confirm.

C37 Analog Teach 10V Auto
-150.0mm

C37 Analog Teach 10V Auto
-150.0mm

Press the + or - key to select the next setting item to be edited.

Press the ● key to edit the selected setting item, and when finished, press the ● key to confirm.

After configuring all settings, press the ■ key twice to return to RUN mode.

Note

When setting the analog output range, the set distance interval cannot be less than 10% of the measurement range.

- Analog Teach 4mA Auto to Analog Teach 20mA Auto
- Analog Teach 0V Auto to Analog Teach 10V Auto

■ Number-based changes

Analog Teach 4mA Manual / Analog Teach 20mA Manual / Analog Teach 0V Manual / Analog Teach 10V Manual / DO2 Teach 1 Manual / DO2 Teach 2 Manual / DO2 Edge Max. / DO2 Edge Min. / DO2 Cycle offset / DO2 Timer set / DO2 Hysteresis / DO2 Tolerance

C38 Analog Teach 0V Manual
220.0mm

Select one of the above settings and press the ● key.

C38 Analog Teach 0V Manual
+0220.0mm

The leftmost digit will be highlighted.

C38 Analog Teach 0V Manual
+0225.0mm

Press the + or - key to edit the highlighted value.

Press the ● key to select the digit to the left.

C38 Analog Teach 0V Manual
225.0mm

After editing the rightmost digit, press the ● key to confirm the set value.

If a value that cannot be set is entered, the numerical value display will flash, and the leftmost digit will be highlighted (prompting the user to set the value again).

Press the + or - key to move to the next item to be configured.

When finished, press the ■ key twice to return to RUN mode.

Note

When setting the analog output range, the set distance interval cannot be less than 10% of the measurement range.

- Analog Teach 4mA Auto to Analog Teach 20mA Auto
- Analog Teach 0V Auto to Analog Teach 10V Auto

3-3-2 [C1] Output2 Mode

The following can also be set for Output 2/Analog output (DO2/AO) in addition to the control output set for DO1.

- Analog output settings (“Analog 4...20mA” or “Analog 0...10V.”)
- Output 1 (DO1) inversion

Other control output settings can be configured similar to DO1 control output 1. (See “[B] Output 1 (DO1) Settings” on page 3-14.)

3-3-3 [C31] Analog Teach 4mA Auto / [C32] Analog Teach 20mA Auto

3-3-4 [C36] Analog Teach 0V Auto / [C37] Analog Teach 10V Auto

When analog output (4...20mA or 0...10V) is selected, teaching is performed to write each threshold to the output range. (The analog output range cannot be set to less than 10% of the measurement range.)

- With “Analog 4...20mA” selected

The current value is displayed in “Analog Teach 4mA Auto,” and pressing the ● key twice writes the value to “Analog Teach 4mA Manual.”

```
[C31] Analog Teach 4mA Auto
-175.0mm
```

The current value is displayed in “Analog Teach 20mA Auto,” and pressing the ● key twice writes the value to “Analog Teach 20mA Manual.”

```
[C32] Analog Teach 20mA Auto
0.0mm
```

- With “Analog 0...10V” selected

The current value is displayed in “Analog Teach 0V Auto,” and pressing the ● key twice writes the value to “Analog Teach 0V Manual.”

```
[C36] Analog Teach 0V Auto
220.0mm
```

The current value is displayed in “Analog Teach 10V Auto,” and pressing the ● key twice writes the value to “Analog Teach 10V Manual.”

```
[C37] Analog Teach 10V Auto
-150.0mm
```

Edits and writes the threshold value written using teaching or the existing setting value as desired. (The analog output range cannot be set to less than 10% of the measurement range.)

See “Number-based changes” on page 3-15.

■ Relationship between analog output setting range and measuring distance

When analog current output (4 to 20 mA) is selected, 21 mA is output outside the measurement range. (The figure below uses the CD2H-350 as an example.)

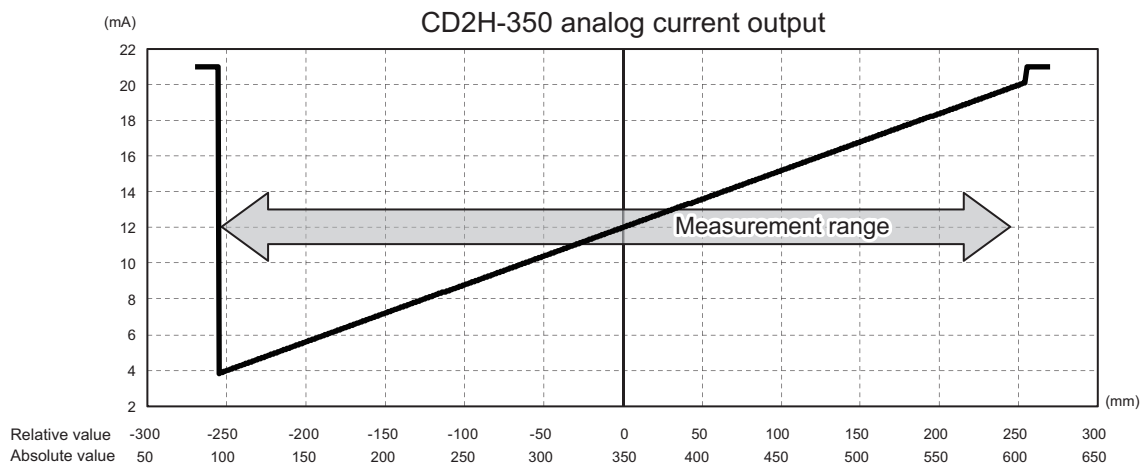

When analog voltage output (0 to 10 V) is selected, 11 V is output outside the measurement range. (The figure below uses the CD2H-350 as an example.)

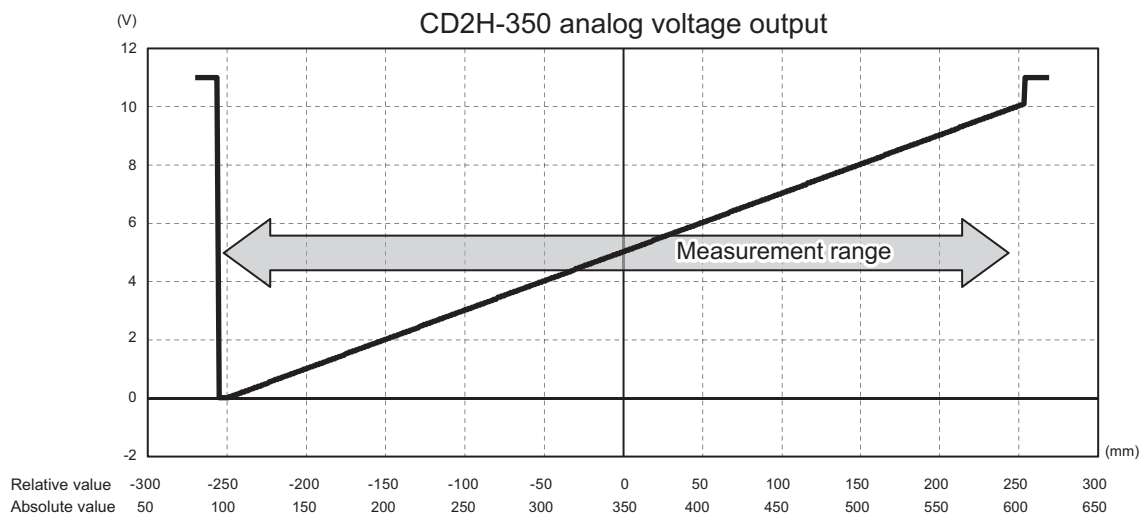

■ Relationship between offset and analog output range

The offset position results in an area being outside the analog output range.

In these examples, measurement continues on the sensor display, but analog output is outside the output range.

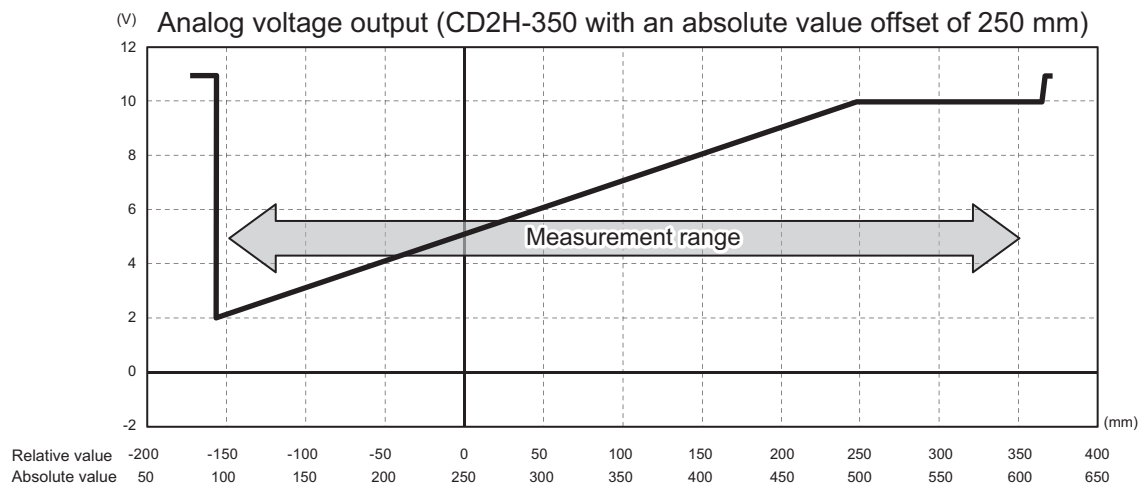
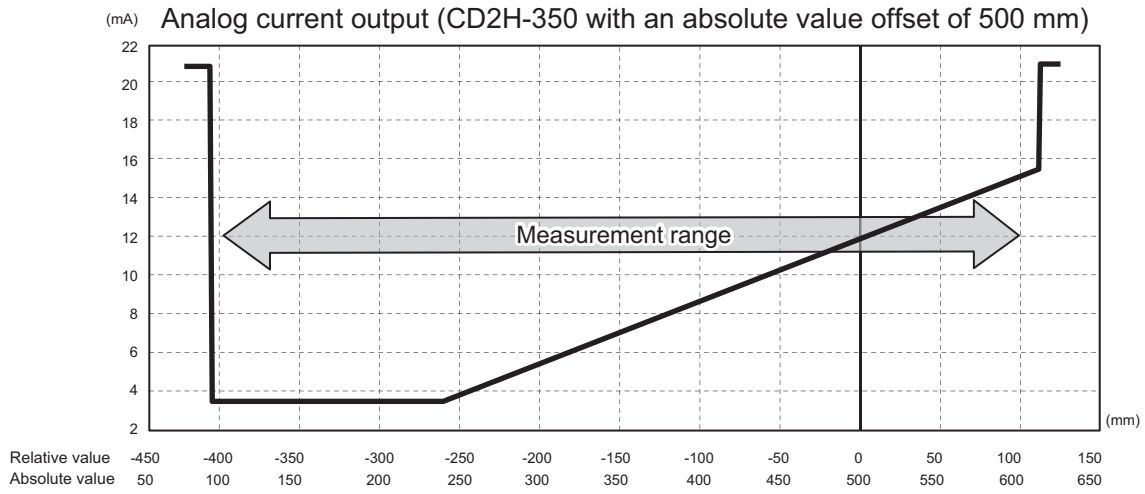

■ Relationship between analog output range setting and analog output

(The figure below uses the CD2H-350 as an example.)

- Analog output current (4...20mA) selected for Output 2/Analog output (DO2/AO)
- When “-100” is input for “Analog Teach 4mA Manual,” and “100” is input for “Analog Teach 20mA Manual”

Even though measurement is being performed on the sensor display, analog output will not change from 21 mA.

* The analog output range cannot be set to less than 10% of the measurement range.

The measurement range for the CD2H-350 becomes 100 to 600 mm (500 mm range).

When “Analog Teach 4mA Manual” is “0” (zero), “49.99 mm” cannot be input for “Analog Teach 20mA Manual.”

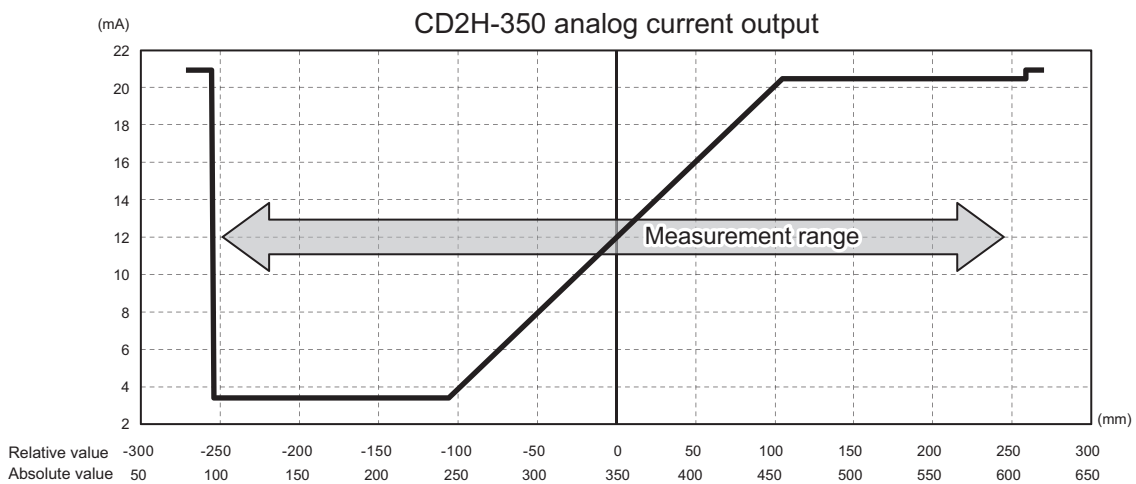

■ Analog output tilting

(The figure below uses the CD2H-350 as an example.)

- Analog output current (4...20mA) selected for Output 2/Analog output (DO2/AO)
- When “100” is input for “Analog Teach 4mA Manual” (or “Analog Teach 0V Manual”) and “-100” is entered for “Analog Teach 20mA Manual” (or “Analog Teach 10V Manual”)

The tilt can also be reversed by changing “Measurement direction” in the measurement settings.

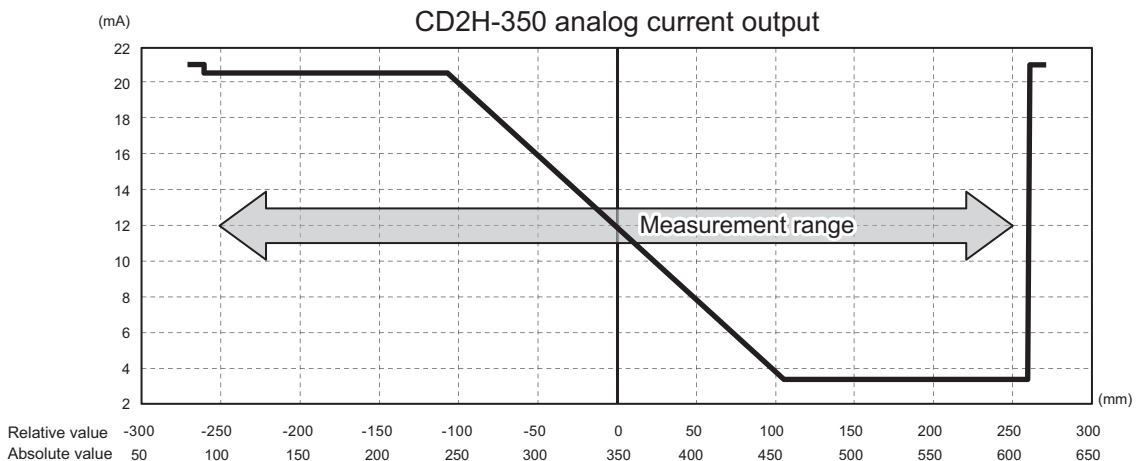

■ Offset operation and analog output after changing analog output setting range

If offset operation is performed after changing the analog output setting range, the offset point will be set to the median value of analog output.

Example:

- (1) Analog output behavior when “-50mm” is input for “Analog Teach 4mA Manual” and “150mm” is input for “Analog Teach 20mA Manual”

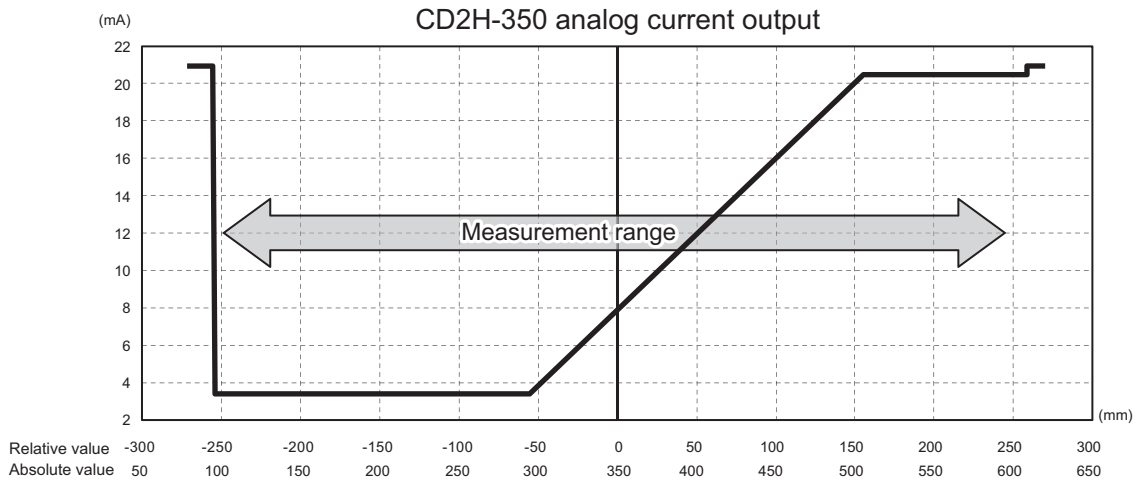

- (2) Analog output behavior after (1) above and offset operation is executed with a relative value of 100 mm

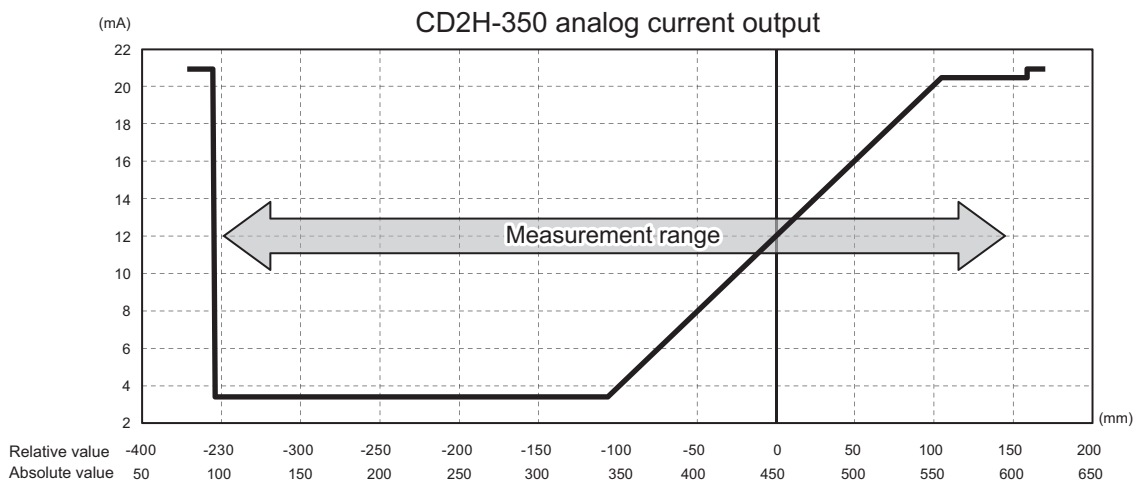

In the above example, although “-50mm” is input for “Analog Teach 4mA Manual” and “150mm” is input for “Analog Teach 20mA Manual,” offset operation results in 4 mA being output when the relative value is “-100mm,” and 20 mA being output when the relative value is “100mm.”

Note that the analog output median value will be set as the offset point, resulting in deviations from the settings for “Analog Teach 4mA Manual” and “Analog Teach 20mA Manual.”

Also, note that the offset can be released so that the conditions described in (1) above are applied.

3-3-7 [C6] DO2 Teach 1 Auto / [C7] DO2 Teach 2 Auto

The settings for “[B6] DO1 Teach 1 Auto / [B7] DO1 Teach 2 Auto” (page 3-21) can also be used for DO2 (Output 2).

3-3-8 [C8] DO2 Teach 1 Manual / [C9] DO2 Teach 2 Manual

The settings for “[B8] DO1 Teach 1 Manual / [B9] DO1 Teach 2 Manual” (page 3-22) can also be used for DO2 (Output 2).

3-3-9 [C11] DO2 Edge Min.

The settings for “[B11] DO1 Edge Min.” (page 3-22) can also be used for DO2 (Output 2).

3-3-10 [C12] DO2 Edge Max.

The settings for “[B12] DO1 Edge Max.” (page 3-22) can also be used for DO2 (Output 2).

3-3-11 [C13] DO2 Switch direction

The settings for “[B13] DO1 Switch direction” (page 3-23) can also be used for DO2 (Output 2).

3-3-12 [C14] DO2 Cycle offset

The settings for “[B14] DO1 Cycle offset” (page 3-23) can also be used for DO2 (Output 2).

3-3-13 [C16] DO2 Output mode

The settings for “[B16] DO1 Output mode” (page 3-24) can also be used for DO2 (Output 2).

3-3-14 [C17] DO2 Delay timer

The settings for “[B17] DO1 Delay timer” (page 3-25) can also be used for DO2 (Output 2).

3-3-15 [C18] DO2 Timer set

The settings for “[B18] DO1 Timer set” (page 3-26) can also be used for DO2 (Output 2).

3-3-16 [C19] DO2 Hysteresis

The settings for “[B19] DO1 Hysteresis” (page 3-27) can also be used for DO2 (Output 2).

3-3-17 [C20] DO2 Tolerance

The settings for “[B20] DO1 Tolerance” (page 3-27) can also be used for DO2 (Output 2).

3-3-18 [C40] DO2 Edge hold

The settings for “[B21] DO1 Edge hold” (page 3-27) can also be used for DO2 (Output 2).

■ Output 1 (DO1) and Output 2/Analog output (DO2/AO) detection mode setting parameters

	Output 1, Output 2						Output 2 only		
	1 point	Zone	FGS2	No measurement	Light level error	Edge	Analog 4...20mA	Analog 0...10V	Output 1 inversion
Output 2 Teach 4mA Auto							✓		
Output 2 Teach 20mA Auto							✓		
Output 2 Teach 4mA Manual							✓		
Output 2 Teach 20mA Manual							✓		
Output 2 Teach 0V Auto								✓	
Output 2 Teach 10V Auto								✓	
Output 2 Teach 0V Manual								✓	
Output 2 Teach 10V Manual								✓	
Output 1, Output 2 Teach 1 Auto	✓	✓	✓		✓				
Output 1, Output 2 Teach 2 Auto		✓							
Output 1, Output 2 Teach 1 Manual	✓	✓	✓		✓				
Output 1, Output 2 Teach 2 Manual		✓							
Output 1, Output 2 Edge Min.						✓			
Output 1, Output 2 Edge Max.						✓			
Output 1, Output 2 Switch direction						✓			
Output 1, Output 2 Cycle offset						✓			
Output 1, Output 2 Output polarity	✓	✓	✓	✓	✓	✓			
Output 1, Output 2 Delay timer	✓	✓	✓		✓	✓			
Output 1, Output 2 Delay time	✓	✓	✓		✓	✓			
Output 1, Output 2 Hysteresis	✓	✓	✓			✓			
Output 1, Output 2 Tolerance			✓						

3-4 [D] Input

Used to configure various external input settings (teach input, hold input, offset input, etc.).

3-4-1 Key Operations for Configuring Settings

■ Procedure

RUN mode

Distance(rel.)
150.1mm

Press the ● key.

C Output 2/Analog
D Input

Press the + or - key to highlight "Input."

Press the ● key to edit "Input."

Press the ● key to edit output mode settings. ("Off" or other settings will be highlighted.)

D 1 Input Function
Laser Off

Press the + or - key to select the "Input Function" ("Laser Off," "Hold," etc.), and then press the ● key to confirm.

D 1 Input Function
Input Hold Mode

Press the + or - key to select the next setting item to be edited.

Press the ● key to edit the selected setting item, and when finished, press the ● key to confirm.

D 2 Input Hold Mode
Peak-to-peak value

After configuring all settings, press the ■ key twice to return to RUN mode.

3-4-2 [D1] Input Function

Sets the operation of external input.

- Off: External input is not used (disabled).
- Multi operations: Operation is performed using the following functions according to the input time.

Input time

500 to 1000 ms: Laser off input OFF (Laser on)

1000 to 1500 ms: Laser off input ON (Laser off)

1500 to 2000 ms: Output 1 (DO1) Teach 1 Auto

2000 to 2500 ms: Output 1 (DO1) Teach 2 Auto

2500 to 3000 ms: DO2/AO (Output 2) Teach 1 Auto

3000 to 3500 ms: DO2/AO (Output 2) Teach 2 Auto

3500 to 5000 ms: Offset (Zero point setting)

5000 ms or more: Offset release

External input multi-operation input times and operations

		Input time							
		500 to 1000 ms	1000 to 1500 ms	1500 to 2000 ms	2000 to 2500 ms	2500 to 3000 ms	3000 to 3500 ms	3500 to 5000 ms	More than 5000 ms
Laser off input OFF		✓							
Laser off input ON			✓						
Output1 Mode selection	1 point			Teach 1 Auto					
	Zone			Teach 1 Auto	Teach 2 Auto				
	FGS2			Teach 1 Auto					
	No measurement								
	Light level error								
	Edge								
Output2 Mode selection	Analog 4...20mA					Teach 1 Auto	Teach 2 Auto		
	Analog 0...10V					Teach 1 Auto	Teach 2 Auto		
	1 point					Teach 1 Auto			
	Zone					Teach 1 Auto	Teach 2 Auto		
	FGS2					Teach 1 Auto			
	No measurement								
	Light level error								
Edge									
Zero point teach								✓	
Zero point teach reset									✓

- Input Hold Mode: Select when using various hold functions.
 - When “Hold” is selected for the “Input Function,” the Hold Selection menu will be displayed. (Select from “Measured value,” “Peak value,” “Lowest value,” “Peak-to-peak value,” “Auto peak value,” “Auto lowest value,” “Average value,” or “Normal.”)
 - Use the input terminal as hold input or hold reset input.
 - Hold input: When selecting “Measured value,” “Peak value,” “Lowest value,” “Peak-to-peak value,” “Average value,” or “Normal” as the hold mode
 - Hold reset input: When selecting “Auto peak value” or “Auto lowest value” as the hold mode
 - * See “[D2] Input Hold Mode” (page 3-41) for more information on Input Hold Mode and the external input function.

- Zero point teach: Use the input terminals as zero point teach or zero point teach reset.
 - [D5] “Trigger on” selected as the input mode
 - Input ON rising edge: Zero point teach operation
 - Input time 1000 ms or more falling edge: Zero point teach reset
 - [D5] “Trigger off” selected as the input mode
 - Input OFF falling edge: Zero point teach operation
 - Input ON state: Zero point teach reset

- Laser off: Use the input terminals as laser off input. The laser will turn ON during input, and measurement will stop.
 - [D5] “Trigger on” selected as the input mode
 - With input ON: Laser off input ON (Laser off)
 - With input OFF: Laser off input OFF (laser on, measurement)
 - [D5] “Trigger off” selected as the input mode
 - With input ON: Laser off input OFF (laser on, measurement)
 - With input OFF: Laser off input ON (Laser off)

- Default value: Laser off

3-4-3 [D2] Input Hold Mode

Sets various hold operations for the measured value.

- Measured value: When “Trigger on” is selected as the input mode, the external input (hold input) rising edge measured value is output. When “Trigger off” is selected as the input mode, the external input (hold input) falling edge measured value is output. (Control output/Analog output)

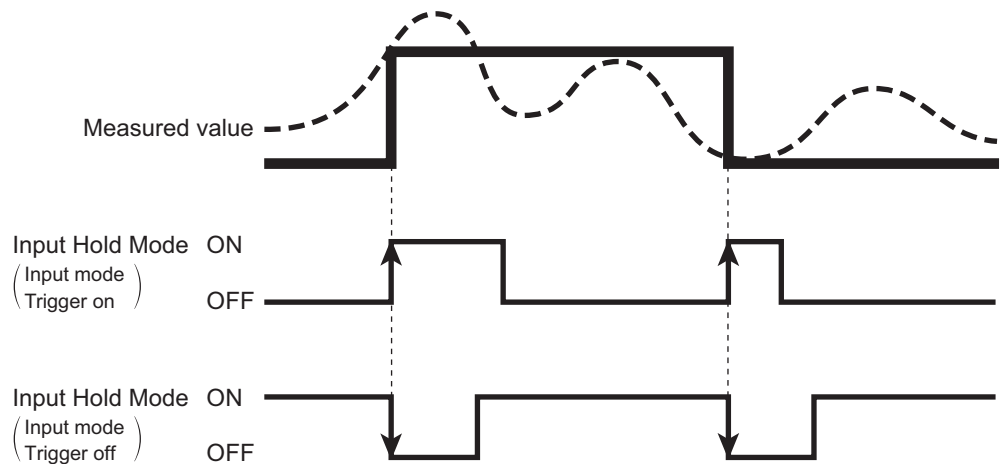

- Peak value: When “Trigger on” is selected as the input mode, the maximum value while the external input (hold input) is off is displayed and held as the next rising edge. When “Trigger off” is selected as the input mode, the maximum value while the external input (hold input) is on is displayed and held as the next falling edge. (Control output/Analog output)

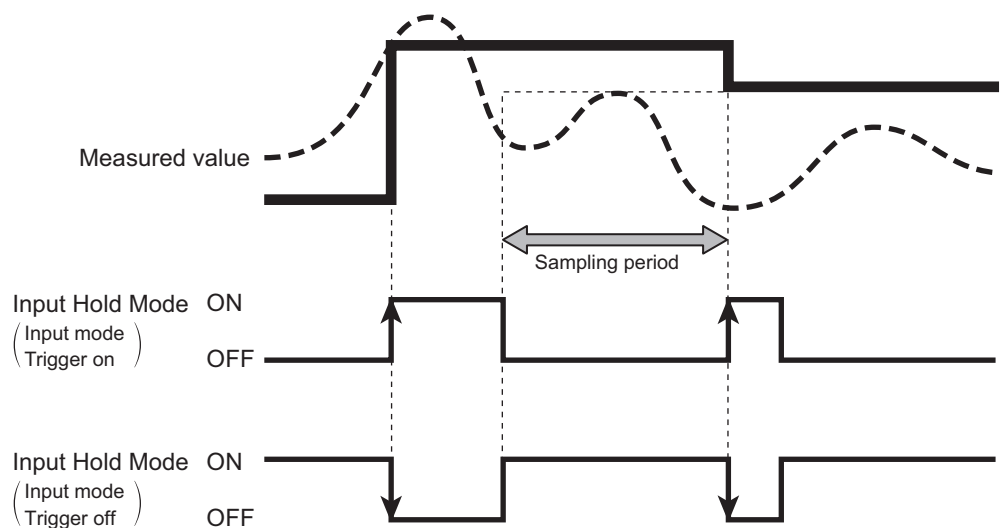

- **Lowest value:** When “Trigger on” is selected as the input mode, the maximum value while the external input (hold input) is off is displayed and held as the next rising edge. When “Trigger off” is selected as the input mode, the maximum value while the external input (hold input) is on is displayed and held as the next falling edge. (Control output/ Analog output)

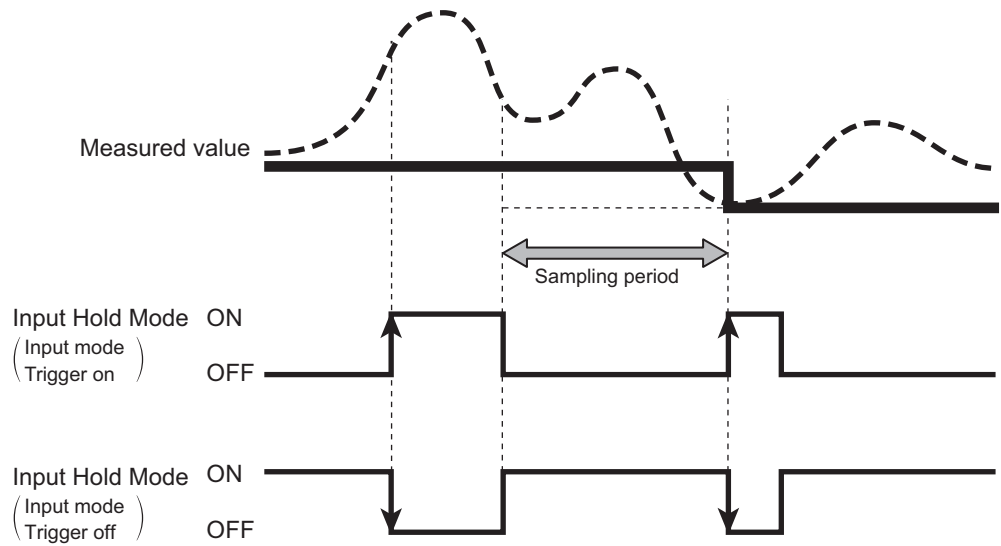

- **Peak-to-peak value:** When “Trigger on” is selected as the input mode, the difference between the maximum value and minimum value while the external input (hold input) is off is displayed and held as the next rising edge. When “Trigger off” is selected as the input mode, the difference between the maximum value and minimum value while the external input (hold input) is on is displayed and held as the next falling edge. (Control output/Analog output)

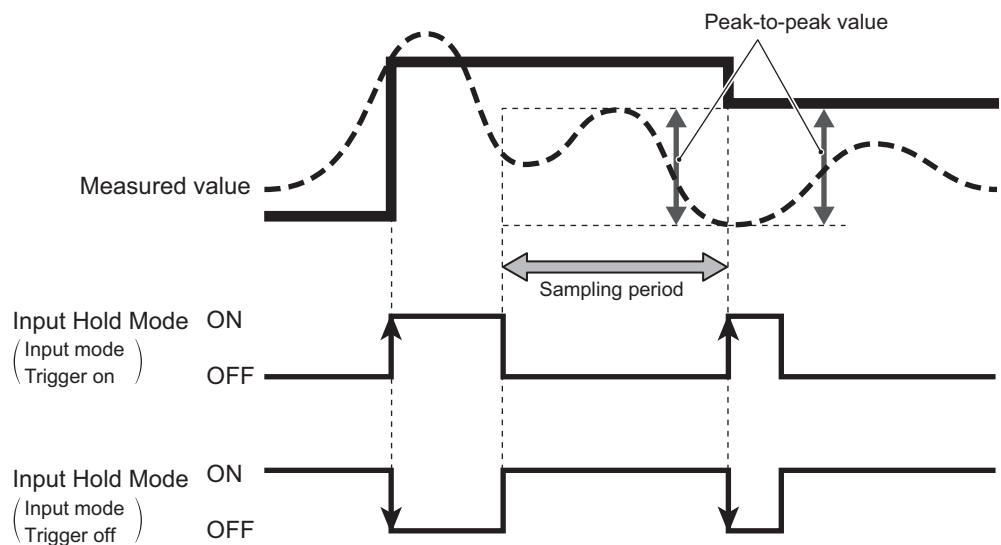

- Auto peak value: Automatically updates the peak value.

When “Trigger on” is selected as the input mode, the value is reset to the current value at the rising edge of the external input (hold reset input).

When “Trigger off” is selected as the input mode, the value is reset to the current value at the falling edge of the external input (hold reset input). (Control output/Analog output)

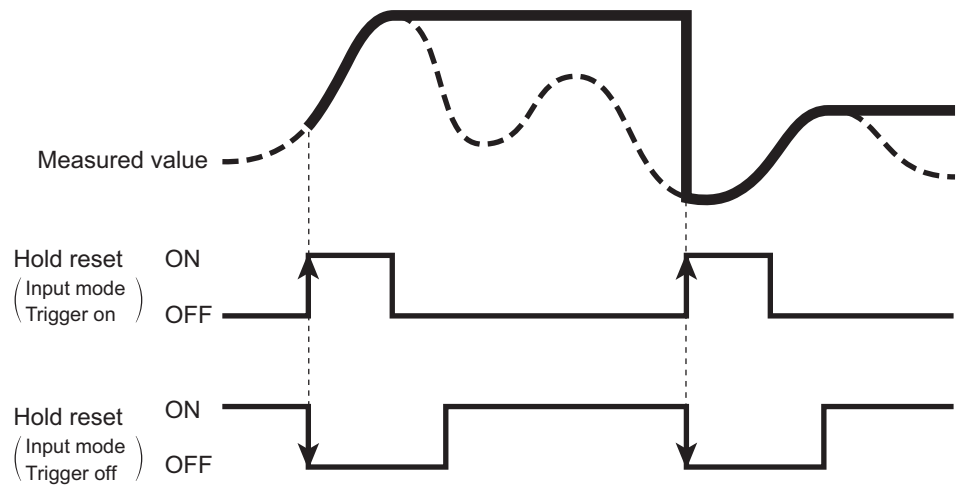

- Auto lowest value: Automatically updates the bottom value.

When “Trigger on” is selected as the input mode, the value is reset to the current value at the rising edge of the external input (hold reset input).

When “Trigger off” is selected as the input mode, the value is reset to the current value at the falling edge of the external input (hold reset input). (Control output/Analog output)

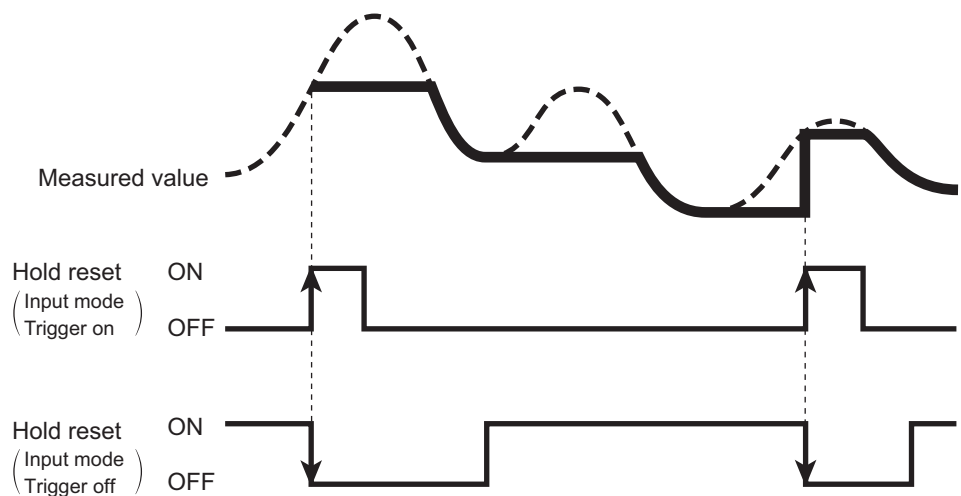

- Average value: When “Trigger on” is selected as the input mode, the average value while the external input (hold input) is off is displayed and held as the next rising edge. When “Trigger off” is selected as the input mode, the average value while the external input (hold input) is on is displayed and held as the next falling edge. (Control output/ Analog output)

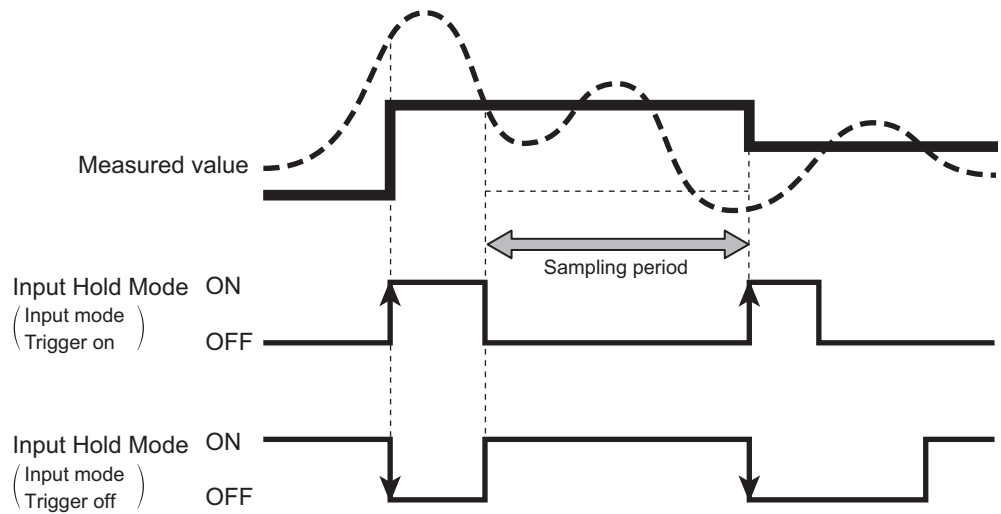

- Normal: When “Trigger on” is selected as the input mode, the measured value is held while the external input (hold input) is on. When “Trigger off” is selected as the input mode, the measured value is held while the external input (hold input) is off. (Control output/Analog output)

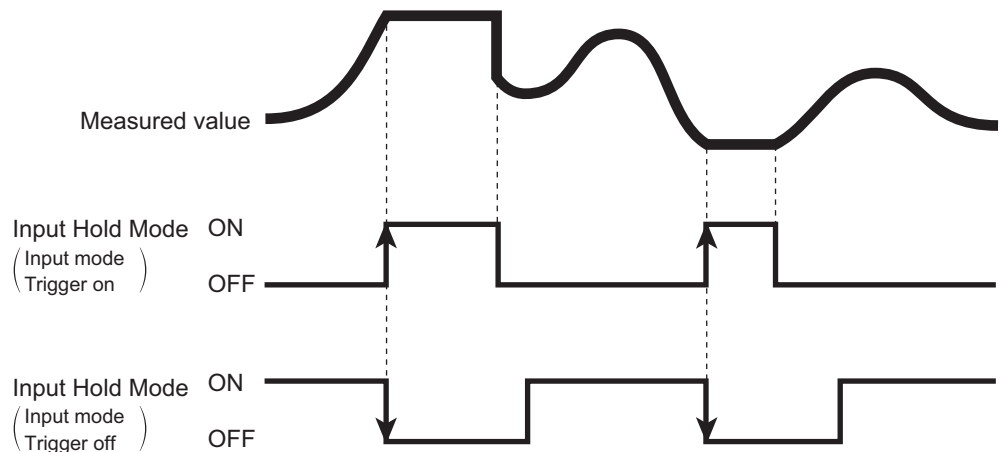

3-4-4 [D4] Input delay

Operates as an input when the input continues for longer than the delay time (100 ms) when input delay is enabled.

This function prevents external inputs from turning on/off at high speed.

- No: Input delay OFF
- Yes: Input delay ON (100 ms)
- Default value: No

* The minimum input time is 6 ms.

3-4-5 [D5] Input mode

Sets the external input operation polarity.

- Trigger on: Turns the trigger on at input.
- Trigger off: Turns the trigger off at input.
- Default value: Trigger on

3-5 [E] Device

Configures various device settings (initialization, display language, no. of decimal places, inverted display, etc.).

3-5-1 Key Operations for Configuring Settings

■ Procedure

RUN mode

```
Distance(rel.)
-----
150.1mm
```

Press the ● key.

```
[E] Device
[F] Information
```

Press the + or - key to highlight "Device."

Press the ● key to edit "Device." ("Reset factory settings" will be displayed.)

```
[E] 1 Reset factory settings
```

```
[E] 6 Language
-----
Japanese
```

Press the + or - key to select the setting item ("Language," "No of decimal places," "Rotate display," etc.), and then press the ● key to confirm.

```
[E] 6 Language
-----
English
```

Press the + or - key to select the next setting item to be edited.

Press the ● key to edit the selected setting item, and when finished, press the ● key to confirm.

After configuring all settings, press the ■ key twice to return to RUN mode.

3-5-2 [E1] Reset factory settings

Initializes the device and restores factory settings.

- Yes: Perform initialization.
- No: Cancels initialization.

After resetting the device to factory settings, "Initial Setting" immediately begins. The setup procedure is as follows.

- (1) Press the ● key to access language selection. "(Language English)" is displayed.
- (2) Press the ● key to change the language.
- (3) Press the + or - key to select the desired language, and then press the ● key.
- (4) "(Output PNP/NPN/PP)" will be displayed in the selected language.
- (5) Press the ● key to apply PP (Push-Pull). "(PP)"
- (6) Press the + or - key to select the desired output, and then press the ● key.
- (7) "Setting finish" will be displayed.
- (8) Press the ● key to return to RUN mode.

3-5-3 [E2] Reset customer settings

Initializes the device using previously saved settings.

- No: Cancels initialization.
- Yes: Initializes the device using previously saved settings.

3-5-4 [E3] Save customer settings

Saves the current settings for use as default values.

- No: Does not save the current settings as customer settings.
- Yes: Saves the current settings as customer settings.

3-5-5 [E4] Span Teach Reset

Releases (initializes) the adjustments made with [A8] Span Teach, Auto and [A9] Span Teach, Manual. The offset is also released when Span Teach Reset is executed. (The measured value offset will become zero.)

- No: Cancels initialization.
- Yes: Initializes the measured value adjustment.

3-5-6 [E6] Language

Sets the display language.

- Select from English, German, Spanish, Japanese, Simplified Chinese, Traditional Chinese, or Korean.
- Default value: Selected during “Initial Setting.”

3-5-7 [E7] No of decimal places

Sets the number of decimal places to display.

- 0: No decimal place
- 0.1: First decimal place
- 0.01: Second decimal place

The selection choices vary depending on the model (distance).

- CD2H-30xxxA/CD2H-50xxxA: Select from 0, 0.1, 0.01, or 0.001.
Default value: 0.01 mm
- CD2H-130xxx/CD2H-245xxx/CD2H-350xxx/CD2H-700xxx: Select from 0, 0.1, or 0.01.
Default value: 0.1 mm

3-5-8 [E11] Display off time

Sets the time until the display turns off after key operation stops.

Changing this setting to 0 seconds will cause the OLED display to stay on, shortening the life of the component.

Set the display off time to 10 seconds or more whenever possible.

The OLED display will turn back on if any of the operation keys are pressed.

- Off: The display brightness will be set to 20%, and the display will stay on.
- 10sec or more: The set display brightness and off time will be applied. The display will turn off after the display off time has passed.
- Default value: 300sec

3-5-9 [E12] Display brightness

Sets the brightness of the display.

- Default value: 20%

3-5-10 [E13] Rotate display

Sets the display orientation.

The standard orientation is with the [■] key toward the top.

- 0°: The display is not flipped horizontally.
- 180°: The display is flipped horizontally. (For use when looking at the display upside-down.)
- Default value: 0°

3-5-11 [E16] Laser

Manually turns the laser on or off.

- On: Turns the laser on.
- Off: Turns the laser off.

3-5-12 [E17] Output NPN/PNP/PP

Switches the output between PNP/NPN and Push-pull.

- PNP: Operates in PNP.
- NPN: Operates in NPN.
- PP: Operates in Push-pull.
- Default value: Selected during "Initial Setting."

3-6 [F] Information

Displays information about the device.

3-6-1 Key Operations for Configuring Settings

■ Procedure

RUN mode

```
Distance(rel.)
-----
150.1mm
```

Press the ● key.

```

↓
[E] Device
[F] Information
```

Press the + or - key to highlight "Information."

Press the ● key to access the "Information" menu. ("Model number" will be displayed.)

```

↓
[F 1] Model number
-----
0000
```

```

↓
[F 6] Sensor operating hours
-----
62:18:09
```

Press the + or - key to select the item ("Serial number," "Sensor operating hours," "Laser operating hours," etc.) to be checked.

After confirming all items, press the ■ key twice to return to RUN mode.

3-6-2 [F1] Model number

Displays the model number.

3-6-3 [F2] Serial number

Displays the serial number.

3-6-4 [F3] Firmware version

Displays the firmware version.

3-6-5 [F6] Sensor operating hours

Displays the total sensor ON time. (HH: MM: SS)

3-6-6 [F7] Laser operating hours

Displays the total hours that the sensor laser has been in operation. (HH: MM: SS)

3-6-7 [F8] Internal temperature

Displays the internal temperature of the sensor.

3-6-8 [F11] Error count

Displays the number of times the following error situations have occurred.

- Displayed when the internal temperature exceeds 70°C.
- Displayed when the internal temperature drops below -20°C.
- Displayed when the power supply voltage falls below 9 V.
- Displayed when overheating occurs (when the internal temperature exceeds 140°C).
- Displayed when an IO-Link communication error occurs.

3-6-9 [F13] Error history

Displays the following.

- 0x00000001: Displayed as “0x01” on the display of the CD2H.
Over-temperature (An error will occur if the internal temperature rises above 70°C.)
Displayed when the internal temperature exceeds 70°C.
- 0x00000002: Displayed as “0x02” on the display of the CD2H.
Under-temperature (An error will occur if the internal temperature drops below -20°C.)
Displayed when the internal temperature drops below -20°C.
- 0x00000005: Displayed as “0x05” on the display of the CD2H.
Low voltage (An error will occur when the power supply voltage drops below about 9V (*1).)
(*1 There are variations in voltage values. (Min. 6 V, Typ. 7.2 V, Max. 9 V))
Displayed when the power supply voltage falls to 9 V or less. (Detected voltages may vary. (Min. 6 V, Max. 9 V))
- 0x00000006: Displayed as “0x06” on the display of the CD2H.
Overheat (An error will occur if the internal temperature rises above 140°C.)
Displayed when overheating occurs (when the internal temperature exceeds 140°C).



4

IO-Link

This chapter introduces how to use the product as an IO-Link device.

4-1 IO-Link Master UR Series Connection Operation Settings

4-1-1 Connecting the CD2H and the UR

- Brown wire (power supply +) from CD2H
— L+ terminal block on UR
- Black wire (signal wire) from CD2H
— I/O terminal block on UR
- Blue wire (power supply -) from CD2H
— M terminal block on UR

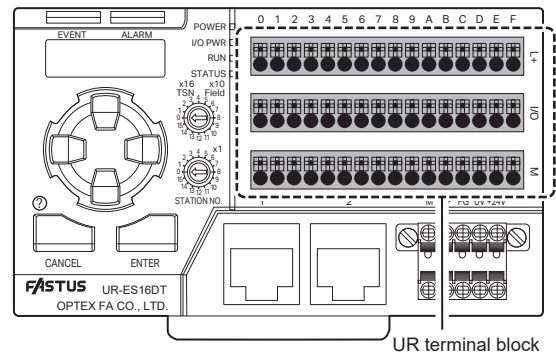

4-1-2 Functions When Connecting the CD2H and the UR

■ Checking the connected model name on the process data monitor

The connected model name, such as “P1. CD2H-245xxx,” can be displayed on the display.

■ Checking the current measured value on the process data monitor

Display example: “P3. Distance 150.1 mm”

The four following process data can be displayed by configuring the “D40. Process data select” settings under Device settings.

- Distance + DO1/DO2
- Received light amount + DO1/DO2
- DO1 edge amount + DO1/DO2
- DO2 edge amount + DO1/DO2

■ Backing up/restoring CD2H settings to the UR from the master parameters menu

- CD2H settings can be backed up to the UR (automatically or manually).
- Settings backed up to the UR can be uploaded to the CD2H (automatically or manually).

● Application example

Connect the CD2H and the UR.

Set the “M31. Automatic device parameter backup” for the master parameter on the UR to “Both.”

(The latest CD2H settings will be automatically backed up to the UR.)

(The settings backed up to the UR will be automatically uploaded to the CD2H.)

If the CD2H becomes damaged for some reason, the settings backed up to the UR will be automatically uploaded if a different CD2H of the same model is connected.

■ Changing CD2H settings from the UR using the Device settings menu

The CD2H settings can be checked using the UR.

● Application example

The CD2H settings can be checked and edited using key operations on the UR.

The CD2H measured values can be checked using key operations on the UR.

4-2 Front Panel Operations of the UR

4-2-1 Overview of Display Operations

The following display operations can be made through the front panel of the UR.

- Process data display
- Master parameter display
- Device setting display
- Event/error display

The displays are operated, using the following keys.

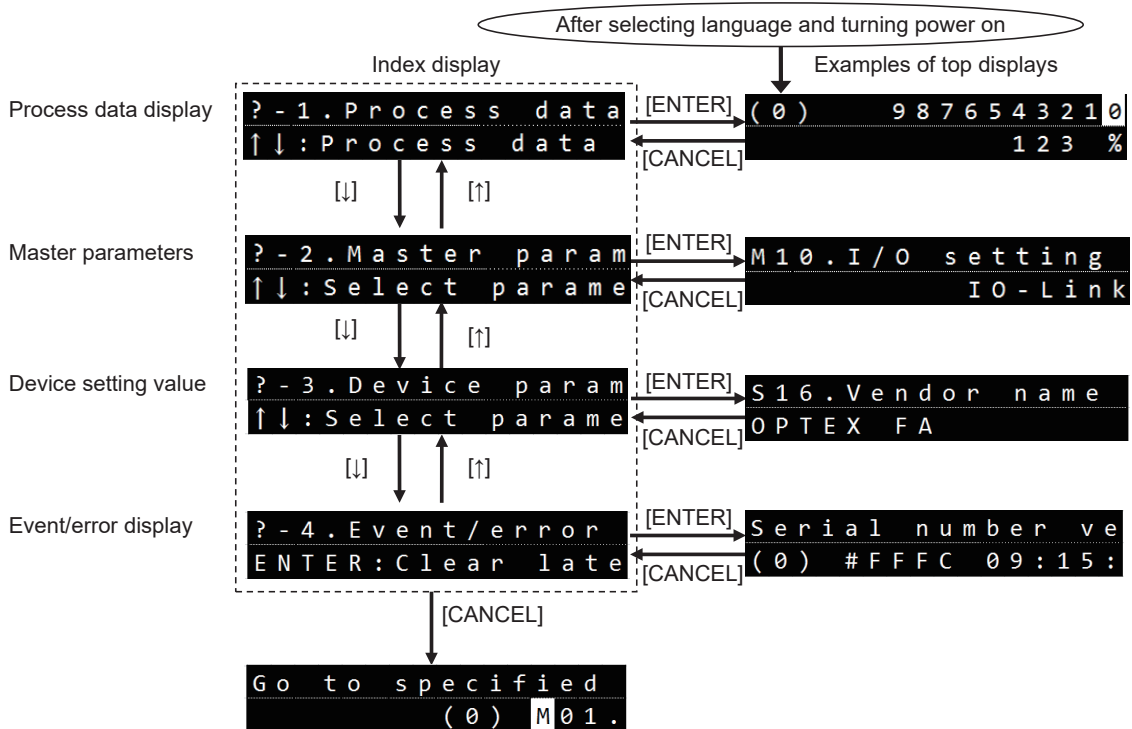
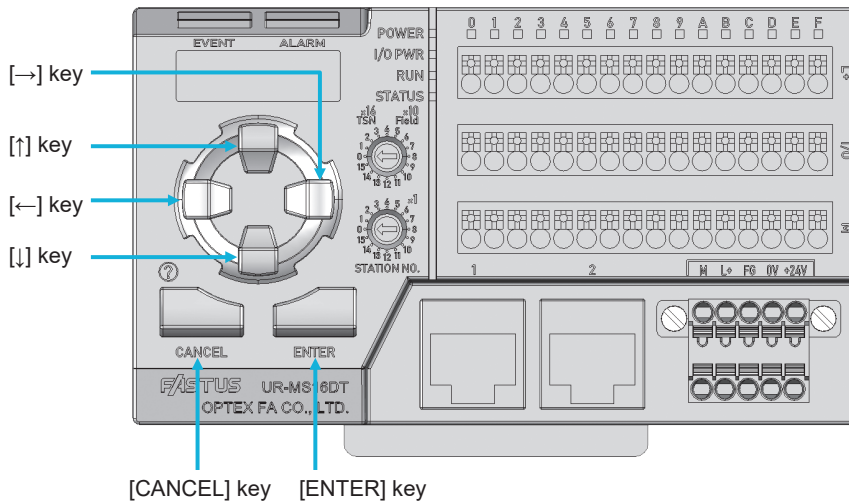

4-2-2 Master Parameters Display

Through the operations of front panel of the UR, the master parameters, user settings, of the UR can be edited and monitored.

Index display:

```
? - 2 . M a s t e r   p a r a m
↑ ↓ : S e l e c t   p a r a m e
```

Display transition:

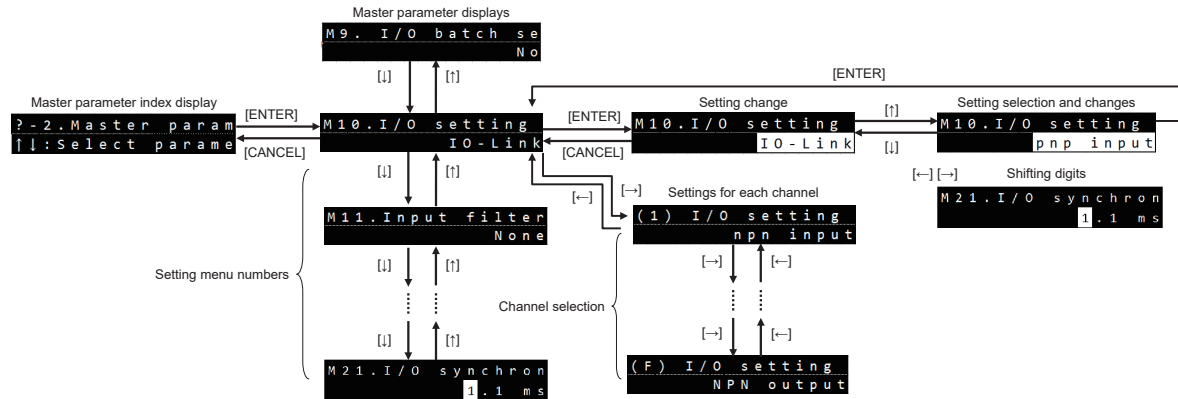

Note: “M5. Language” will be displayed, when the power is turned on for the first time. See “2-4-2 Language” in each IO-Link master’s user’s manual for further information.

Description of each display:

The following are displayed on the upper row.

Left: M□: (setting menu number of this product)

Right: Setting name

The setting value is displayed on the lower row.

Example:

```
Setting menu number  Setting name
M 1 0 . I / O   s e t t i n g
I O - L i n k
Setting value
```

Channel settings

Example:

Channel number display (will switch to channel number display when the channel is switched or five seconds have passed).

```
( 1 ) I / O   s e t t i n g
n p n   i n p u t
```

■ UR master settings: Detailed explanation of backup and restore

Setting items	Setting value range	Description
M31. Automatic device parameter backup	None (default value)	Restore and backup are not automatically performed. Storage functionality is controlled manually (M32. Device parameter backup/restore).
	Backup	Automatically perform a backup (upload parameters to the UR) when there is a change to the setting values of the CD2H. If parameters of the CD2H are changed from the UR, the backup operation will automatically start 10 seconds after the last change. Note: If a device with a different vendor ID or device ID is connected, a backup will be performed each time upon startup. Re-configure "M30. Device validation" immediately to clear the validation error (FFFE h).
	Restore	Automatically restore (download parameters from the UR to the CD2H) if the parameters of the CD2H differ from the data stored on the UR during startup. In this case, note that even if the set values of the CD2H are changed, it will be overwritten at the next startup with the data saved in the UR.
	Both	Automatically perform both backup and restore. The storage data stored on the UR will always match the parameters of the CD2H. In other words, parameters of the CD2H are backed up to the UR whenever they are changed. If any parameter is different from the CD2H during startup, the parameters stored in the UR will be restored.
M32. Device parameter backup/restoration	No (default value)	Manual backup/restore of parameters is not performed.
	Backup	Manually backup the CD2H (upload parameters from the CD2H to the UR).
	Restore	Manually restore to the CD2H (download parameters from the UR to the CD2H). Note: This will not be performed if there is no backup data stored in the UR.
	Delete	Delete backup data stored in the UR. Note: This will not be performed if there is no backup data stored in the UR.

4-2-3 Device Identification Display

Device information from the CD2H can be confirmed and a specified index number can be read and written by the UR.

The specified index number can be written even if IO-Link data is not installed.

Index display:

```
? - 3 . Device param
↑↓: Select parame
```

(Not displayed if no IO-Link device is connected)

Menu transitions:

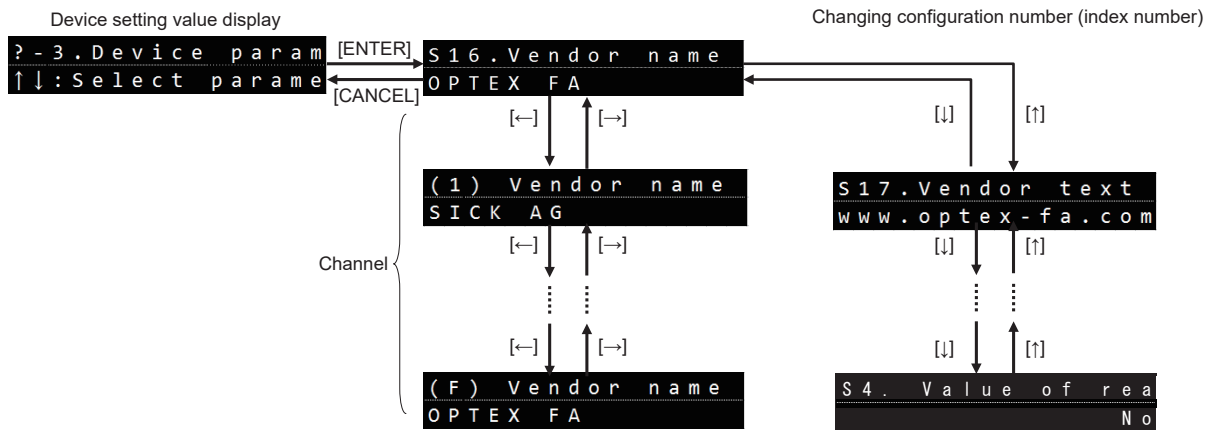

Description of each display:

The following are displayed on the upper row.

Left: Sx: IO-Link device index number

Right: Setting name

The setting parameter is displayed on the lower row.

Example:

```

Index      IO-Link device setting name
number
┌────────┬───────────────────────────────────┐
│ S 1 6 . V e n d o r   n a m e       │
├────────┴───────────────────────────────────┤
│ O P T E X   F A                       │
└────────┬───────────────────────────────────┘
          Setting parameter
  
```

■ UR device settings: Detailed information on CD2H settings

Number	Setting items	Description	Setting value range/options
D1	Reset	Configures the settings related to initialization.	*****, Reset factory setting, Save customer setting, Reset customer setting
D2	Cycle time	Configures the sampling period settings.	AUTO, 133 μ s, 150 μ s, 200 μ s, 300 μ s, 500 μ s, 1 ms, 2 ms, 5 ms
D3	Average filter	Sets the number of measurements to perform for the moving average.	Off, 4, 8, 16, 32, 64, 128, 256, 512
D4	Median filter	Sets the number of measurements to use for the median filter.	Off, 3, 7, 15, 31
D5	Measurement direction	Select from Positive or Negative.	Positive, Negative
D6	Measurement value offset	Stores the difference value to set the display to zero.	This setting stores the difference value to set the display to zero when zero-point teaching (offset) is used.
D7	Error mode	Selects whether to use hold or clamp value operation.	Substitute value, Hold last value, Hold last value + timer
D8	Substitute values	Sets the display value to use when measurement is not possible.	Set a numerical value.
D9	Q1 Switchpoint mode	Sets the DO1 Output mode.	Deactivated, 1point, Zone, FGS2, No measurement, Light level error, Edge
D10	Q1 SP1 sensing range	Sets DO1 Teach 1 Manual.	Set a numerical value.
D11	Q1 SP2 sensing range	Sets DO1 Teach 2 Manual.	Set a numerical value.
D12	Q1 Switchpoint logic	Sets the DO1 Output mode.	High-active (Not inverted), Low-active (Inverted) (Use High-active in general and Low-active for inverted operation.)
D13	Q1 Switchpoint hysteresis	Sets the DO1 Hysteresis.	Set a numerical value.
D14	Q1 Timer mode	Sets the DO1 Delay timer.	Deactivated, T-on delay, T-off delay, T-on/T-off delay, Impulse (one shot)
D15	Q1 Timer setup (setup time in ms)	Sets the DO1 Timer set.	Set a numerical value from 1 ms.
D16	Q1 ObSB tolerance	Sets the DO1 Tolerance.	Set a numerical value. (This becomes the detection margin when FGS2 is selected as the Output1 Mode.)
D17	Q1 Cycle offset	Sets the DO1 Cycle offset.	Set a numerical value. (This becomes the setting value of the previous measured value used for difference calculation when edge mode is selected as the Output1 Mode.)
D18	Q1 Min height jump	Sets the DO1 Edge Min.	Set a numerical value.
D19	Q1 Max height jump	Sets the DO1 Edge Max.	Set a numerical value.
D20	Q1 Edge Hysteresis	Sets the hysteresis for DO1 Edge.	Set a numerical value. (Displayed only when connected to the UR, and applied only when edge mode is used.)
D21	Q1 Switch direction	Sets the DO1 Switch direction.	Both edges, Negative, Positive
D22	Q1 Edge Hold	Sets the DO1 Edge hold.	OFF, Hold (Values within the range of Edge Min./Edge Max. will be held.)

Number	Setting items	Description	Setting value range/options
D23	Q2 Switchpoint mode	Sets the Output2 Mode.	Deactivated, Analog 4-20mA, Analog 0-10V, 1 point, Zone, FGS2, No measurement, Light level error, Edge, Q1 Not
D24	Q2 SP1 sensing range	Sets DO2 Teach 1 Manual.	Set a numerical value.
D25	Q2 SP2 sensing range	Sets DO2 Teach 2 Manual.	Set a numerical value.
D26	Q2 Switchpoint logic	Sets the DO2 Output mode.	High-active (Not inverted), Low-active (Inverted) (Use High-active in general and Low-active for inverted operation.)
D27	Q2 Switchpoint hysteresis	Sets the DO2 Hysteresis.	Set a numerical value.
D28	Q2 Timer mode	Sets the DO2 Delay timer.	Deactivated, T-on delay, T-off delay, T-on/T-off delay, Impulse (one shot)
D29	Q2 Timer setup (setup time in ms)	Sets the DO2 Timer set.	Set a numerical value from 1 ms.
D30	Q2 ObSB tolerance	Sets the DO2 Tolerance.	Set a numerical value. (This becomes the detection margin when FGS2 is selected as the Output2 Mode.)
D31	Q2 Cycle offset	Sets the DO2 Cycle offset.	Set a numerical value. (This becomes the setting value of the previous measured value used for difference calculation when edge mode is selected as the Output2 Mode.)
D32	Q2 Min height jump	Sets the DO2 Edge Min.	Set a numerical value.
D33	Q2 Max height jump	Sets the DO2 Edge Max.	Set a numerical value.
D34	Q2 Edge Hysteresis	Sets the hysteresis for DO2 Edge.	Set a numerical value. (Displayed only when connected to the UR, and applied only when edge mode is used.)
D35	Q2 Switch direction	Sets the DO2 Switch direction.	Both edges, Negative, Positive
D36	Q2 Edge Hold	Sets the DO2 Edge hold.	OFF, Hold (Values within the range of Edge Min./ Edge Max. will be held.)
D37	Laser ON/OFF	Switches the laser on or off.	ON, OFF
D38	External input configuration	Sets the external input.	off, Sender off, Teach in, Sample HOLD, Peak HOLD, Bottom HOLD, Peak-to-peak HOLD, Auto peak, Auto bottom, Average HOLD, Normal hold, Zero point teach
D39	External input logic	Sets the external input polarity.	High-active (Not inverted), Low-active (Inverted) (Use High-active in general and Low-active for inverted operation.)
D40	Process Data Select	Selects the process data.	Distance + control outputs, Received light amount + control outputs, Timer value + control outputs, Q1 Edge + control outputs, Q2 Edge + control outputs. In addition, these five SSP formats.
D41	Current temperature	Displays the internal temperature of the sensor.	
D42	Operating hours sensor	Displays the operation time of the sensor.	
D43	Operating hours Laser	Displays the operation time of the laser.	

Number	Setting items	Description	Setting value range/options
D44	Firmware version	Displays the firmware version.	

4-3 Index List

Category	Name	Index No. DEC (HEX)	Subindex No.	Read/Write*	Backup	Format	Length in bytes	Default value	Setting Details	Remarks
System	System Command	2 (0x02)	0	W		UINT	1		0x41: Teach SP1 (far) 0x42: Teach SP2 (near) 0x82: Restore Factory settings 0xC0: Restore customer settings 0xC1: Save customer settings 0xC2: Zero point teach 0xC3: Zero point reset	Select the output (Q1 or Q2) to be set at Teach channel "Index No. 58 (0x3A)". SP: Switching Point
	Device Access Lock	12 (0x0C)	0	R/W	✓	UINT	2	0	bit 00: Reserved bit 01: Data storage lock bit 02: Reserved bit 03: Local user interface lock bit 04-15: Reserved	
	Profile Characteristics	13 (0x0D)	0	R		UINT	4	0x4000 0x000B	n+0,n+1: FunctionClass: Device ID n+2,n+3: Profile ID	
			1	R		UINT	2	0x000B	Profile ID 0x000B: Measuring sensor, high resolution	
			2	R		UINT	2	0x4000	FunctionClass: Device ID 0x4000	
Identification	Vendor Name	16 (0x10)	0	R		STRINGS	8	"OPTEX FA"		
	Vendor Text	17 (0x11)	0	R		STRINGS	16	www.optex-fa.com		
	Product Name	18 (0x12)	0	R		STRINGS	18	"CD2H-XXX"		
	Product ID	19 (0x13)	0	R		STRINGS	5	"XXXXX"		
	Product Text	20 (0x14)	0	R		STRINGS	19	"Displacement Sensor"		
	Serial Number	21 (0x15)	0	R		STRINGS	11			
	Hardware Version	22 (0x16)	0	R		STRINGS	4	"MP01"		
	Firmware Version	23 (0x17)	0	R		STRINGS	7	"1.0.0R"		
	Application Specific Tag	24 (0x18)	0	R/W	✓	STRINGS	32	*****		
	Function Tag	25 (0x19)	0	R/W	✓	STRINGS	32	*****		
Location Tag	26 (0x1A)	0	R/W	✓	STRINGS	32	*****			
Error	Error Count	32 (0x20)	0	R		UINT	2	0	Number of errors since last power-on	Cleared when power is turned off.
	Device Status	36 (0x24)	0	R		UINT	1	0x00	0x00: Device OK 0x01: Maintenance required 0x02: Out of specification 0x03: Functional check 0x04: Failure	
	Detailed Device Status	37 (0x25)	0	R		UINT	9	0	Expressed in 3 bytes per set of currently occurring EVENT information EVENT #1 n+0, n+1: EVENT code 0x4210: Internal temperature is +70°C or higher 0x4220: Internal temperature is -20°C or lower n+2: EVENT Details bit 00-02: Source (0: Unknown, 4: Caused by the application.) bit 03: Reserved bit 04-05: Type (1: Notification, 2: Warning, 3: Fault) bit 06-07: Mode (1: Single occurrence, 2: Resolved, 3: Occurrence) Same Format as above for events #2...3 thereafter.	
IO-Link	Process Data Input	40 (0x28)	0	R		INT	6		n+0...n+3: Distance/Edge/Timer value/Received light amount n+4: Reserved n+5: bit 00: Output 1 status bit 01: Output 2 status	See below.
			1	R		INT	4		n+0...n+3: Distance/Edge/Timer value/Received light amount	The values that can be monitored depend on the Process Data Select setting of Index No.120 (0x78).
			2	R		UINT	1		Reserved	

* R: Read Only, R/W: Read/Write, W: Write Only

Category	Name	Index No. DEC (HEX)	Subindex No.	Read/Write*	Backup	Format	Length in bytes	Default value	Setting Details	Remarks
IO-Link	Process Data Input	40 (0x28)	3	R		UINT	1		bit 00: Output 2 status	
			4	R		UINT	1		bit 00: Output 1 status	
Teach	Teach Channel	58 (0x3A)	0	R/W		UINT	1	0	0x00: Q1 0x01: Q1 0x02: Q2	The output is set to Q1 (D01) regardless of whether 0x00 or 0x01 is selected.
	Teach Status	59 (0x3B)	0	R		UINT	1	0	bit 00-03: 0x0: Idle 0x1: SP1 teach success 0x2: SP2 teach success 0x3: SP1, SP2 teach success 0x4: Wait for command 0x5: Busy 0x7: Error bit 04: ON: SP1 teach success OFF: SP1 teach failure bit 05: Reserved bit 06: ON: SP2 teach success OFF: SP2 teach failure bit 07: Reserved	SP: Switching Point
Output Settings	Q1 SP Settings	60 (0x3C)	0	R/W	✓	INT	8	Varies by model	Batch access n+0...n+3: Q1 SP2 n+4...n+7: Q1 SP1	See below for setting range. SP: Switching Point
			1	R/W	✓	INT	4	0	Individual access (Q1 SP1)	Setting range, Unit: nm CD2H-30x: -10000000...10000000 CD2H-50x: -20000000...20000000 CD2H-130x: -140000000...140000000 CD2H-245x: -350000000...350000000 CD2H-350x: -500000000...500000000 CD2H-700x: -1000000000...1000000000
			2	R/W	✓	INT	4	Varies by model	Individual access (Q1 SP2)	Setting range, Unit: nm CD2H-30x: -10000000...10000000 [Default value 5000000] CD2H-50x: -20000000...20000000 [Default value 10000000] CD2H-130x: -140000000...140000000 [Default value 70000000] CD2H-245x: -350000000...350000000 [Default value 175000000] CD2H-350x: -500000000...500000000 [Default value 250000000] CD2H-700x: -1000000000...1000000000 [Default value 500000000]
	Q1 Settings	61 (0x3D)	0	R/W	✓	UINT	6		Batch access n+0...n+3: Hysteresis n+4: Output 1 mode n+5: Output 1 output mode	See below for setting range.
			1	R/W	✓	UINT	1	0x00	Individual access (Output 1 output mode) 0x00: Near On 0x01: Far On	
			2	R/W	✓	UINT	1	0x01	Individual access (Output 1 mode) 0x00: OFF 0x01: 1-point 0x02: Zone 0x80: FGS2 0x82: Alarm 0x83: Received light error 0x84: Edge	
			3	R/W	✓	UINT	4	Varies by model	Individual access (Hysteresis)	Setting range, Unit: nm CD2H-30x: 0...10000000 [Default value 100000] CD2H-50x: 0...20000000 [Default value 200000] CD2H-130x: 0...140000000 [Default value 300000] CD2H-245x: 0...350000000 [Default value 500000] CD2H-350x: 0...500000000 [Default value 1000000] CD2H-700x: 0...1000000000 [Default value 1500000]

* R: Read Only, R/W: Read/Write, W: Write Only

Category	Name	Index No. DEC (HEX)	Subindex No.	Read/Write*	Backup	Format	Length in bytes	Default value	Setting Details	Remarks	
Output Settings	Q2 SP Settings	62 (0x3E)	0	R/W	✓	INT	8	Varies by model	Batch access n+0...n+3: Q2 SP2 n+4...n+7: Q2 SP1	See below for setting range. SP: Switching Point	
			1	R/W	✓	INT	4	Varies by model	Individual access (Q2 SP1)	Setting range, Unit: nm CD2H-30x: -10000000...10000000 CD2H-50x: -20000000...20000000 CD2H-130x: -140000000...140000000 CD2H-245x: -350000000...350000000 CD2H-350x: -500000000...500000000 CD2H-700x: -1000000000...1000000000	
			2	R/W	✓	INT	4	Varies by model	Individual access (Q2 SP2)	Setting range, Unit: nm CD2H-30x: -10000000...10000000 [Default value 5000000] CD2H-50x: -20000000...20000000 [Default value 10000000] CD2H-130x: -140000000...140000000 [Default value 70000000] CD2H-245x: -350000000...350000000 [Default value 175000000] CD2H-350x: -500000000...500000000 [Default value 250000000] CD2H-700x: -1000000000...1000000000 [Default value 500000000]	
	Q2 Settings	63 (0x3F)	0	R/W	✓	UINT	6		Batch access n+0...n+3: Hysteresis n+4: Output 2 mode n+5: Output 2 output mode	See below for setting range.	
			1	R/W	✓	UINT	1	0x00	Individual access (Output 2 output mode) 0x00: Near On 0x01: Far On		
			2	R/W	✓	UINT	1	0x01	Individual access (Output 2 mode) 0x00: OFF 0x01: 1-point 0x02: Zone 0x80: FGS2 0x82: Alarm 0x83: Received light error 0x84: Edge 0x85: Analog 4...20mA 0x86: Analog 0...10V 0x87: Not equal to Q1		
			3	R/W	✓	UINT	4	Varies by model	Individual access (Hysteresis)	Setting range, Unit: nm CD2H-30x: 0...10000000 [Default value 100000] CD2H-50x: 0...20000000 [Default value 200000] CD2H-130x: 0...140000000 [Default value 300000] CD2H-245x: 0...350000000 [Default value 500000] CD2H-350x: 0...500000000 [Default value 1000000] CD2H-700x: 0...1000000000 [Default value 1500000]	

Identification	Device Specific Tag	64 (0x40)		R/W	✓	STRINGS	32	*****			
Output Settings	Setup Edge Q1	93 (0x5D)	0	R/W	✓	UINT	18		Batch access n+0: Edge hold n+1: Switch direction n+2...n+5: Hysteresis n+6...n+9: Edge Max. n+10...n+13: Edge Min. n+14...n+17: Cycle offset	See below.	
			1	R/W	✓	UINT	4	50	Individual access (Cycle offset)	Setting range, Cycle offset 1...10000	
			2	R/W	✓	UINT	4	Varies by model	Individual access (Edge Min.)	Setting range, Unit: nm CD2H-30x: 0...10000000 [Default value 5000000] CD2H-50x: 0...20000000 [Default value 5000000] CD2H-130x: 0...140000000 [Default value 50000000] CD2H-245x: 0...350000000 [Default value 100000000] CD2H-350x: 0...500000000 [Default value 100000000] CD2H-700x: 0...1000000000 [Default value 100000000]	

* R: Read Only, R/W: Read/Write, W: Write Only

Category	Name	Index No. DEC (HEX)	Subindex No.	Read/Write*	Backup	Format	Length in bytes	Default value	Setting Details	Remarks
Output Settings	Setup Edge Q1	93 (0x5D)	3	R/W	✓	UINT	4	Varies by model	Individual access (Edge Max.)	Setting range, Unit: nm CD2H-30x: 0...10000000 [Default value 2000000] CD2H-50x: 0...20000000 [Default value 2000000] CD2H-130x: 0...140000000 [Default value 30000000] CD2H-245x: 0...350000000 [Default value 100000000] CD2H-350x: 0...500000000 [Default value 100000000] CD2H-700x: 0...1000000000 [Default value 100000000]
			4	R/W	✓	UINT	4	Varies by model	Individual access (Hysteresis)	Setting range, Unit: nm CD2H-30x: 0...10000000 [Default value 100000] CD2H-50x: 0...20000000 [Default value 200000] CD2H-130x: 0...140000000 [Default value 300000] CD2H-245x: 0...350000000 [Default value 500000] CD2H-350x: 0...500000000 [Default value 1000000] CD2H-700x: 0...1000000000 [Default value 1500000]
			5	R/W	✓	UINT	1	0x02	Individual access (Switch direction) 0x00: Positive 0x01: Negative 0x02: Both edges	
			6	R/W	✓	UINT	1	0x00	Individual access (Edge hold) 0x00: Off 0x01: Hold	
	Setup Edge Q2	94 (0x5E)	0	R/W	✓	UINT	18		Batch access n+0: Edge hold n+1: Switch direction n+2...n+5: Hysteresis n+6...n+9: Edge Max. n+10...n+13: Edge Min. n+14...n+17: Cycle offset	See below.
			1	R/W	✓	UINT	4	50	Individual access (Cycle offset)	Setting range, Cycle offset 1...10000
			2	R/W	✓	UINT	4	Varies by model	Individual access (Edge Min.)	Setting range, Unit: nm CD2H-30x: 0...10000000 [Default value 500000] CD2H-50x: 0...20000000 [Default value 500000] CD2H-130x: 0...140000000 [Default value 5000000] CD2H-245x: 0...350000000 [Default value 10000000] CD2H-350x: 0...500000000 [Default value 10000000] CD2H-700x: 0...1000000000 [Default value 10000000]
			3	R/W	✓	UINT	4	Varies by model	Individual access (Edge Max.)	Setting range, Unit: nm CD2H-30x: 0...10000000 [Default value 2000000] CD2H-50x: 0...20000000 [Default value 2000000] CD2H-130x: 0...140000000 [Default value 30000000] CD2H-245x: 0...350000000 [Default value 100000000] CD2H-350x: 0...500000000 [Default value 100000000] CD2H-700x: 0...1000000000 [Default value 100000000]
			4	R/W	✓	UINT	4	Varies by model	Individual access (Hysteresis)	Setting range, Unit: nm CD2H-30x: 0...10000000 [Default value 100000] CD2H-50x: 0...20000000 [Default value 200000] CD2H-130x: 0...140000000 [Default value 300000] CD2H-245x: 0...350000000 [Default value 500000] CD2H-350x: 0...500000000 [Default value 1000000] CD2H-700x: 0...1000000000 [Default value 1500000]
			5	R/W	✓	UINT	1	0x02	Individual access (Switch direction) 0x00: Positive 0x01: Negative 0x02: Both edges	
			6	R/W	✓	UINT	1	0x00	Individual access (Edge hold) 0x00: Off 0x01: Hold	

* R: Read Only, R/W: Read/Write, W: Write Only

Category	Name	Index No. DEC (HEX)	Subindex No.	Read/Write*	Backup	Format	Length in bytes	Default value	Setting Details	Remarks	
Other Settings	Sender Configuration	97 (0x61)	0	R/W		UINT	1	0x00	0x00: Sender active 0x01: Sender not active		
IO-Link	Process Data Select	120 (0x78)	0	R/W	✓	UINT	1	0x00	0x00: Distance + Control outputs 0x01: Received light amount + Control outputs 0x02: Timer value + Control outputs 0x03: Q1 Edge + Control outputs 0x04: Q2 Edge + Control outputs 0x05: Distance + Control outputs (SSP format) 0x06: Received light amount + Control outputs (SSP format) 0x07: Timer value + Control outputs (SSP format) 0x08: Q1 Edge + Control outputs (SSP format) 0x09: Q2 Edge + Control outputs (SSP format)		
External Input	External Input Settings	122 (0x7A)	0	R/W	✓	UINT	1	0x10	0x00: Disabled 0x10: Laser off 0x11: Teach 0x50: Measured value (Input Hold Mode) 0x51: Peak value (Input Hold Mode) 0x52: Lowest value (Input Hold Mode) 0x53: Peak-to-peak value (Input Hold Mode) 0x54: Average value (Input Hold Mode) 0x55: Zero point teach 0x56: Auto peak value (Input Hold Mode) 0x57: Auto lowest value (Input Hold Mode) 0x58: Normal (Input Hold Mode)		
Maintenance Information	Internal Temperature	153 (0x99)	0	R		INT	1		Internal temperature	Unit: °C	
	Received Light Amount	175 (0xAF)	0	R		UINT	2				
	Received Light Amount Threshold	176 (0xB0)	0	R/W	✓	UINT	2	1700	0-5000		
	Operating Hours		190 (0xBE)	0	R		UINT	8		Batch access n+0...n+3: Sender operating hours n+4...n+7: Sensor operating hours	Unit: h
					1	R		UINT	4		Individual access (Sensor operating hours)
			2	R		UINT	4		Individual access (Sender operating hours)	Unit: h	
Other Settings	Find Me	204 (0xCC)	0	R/W		UINT	1	0	0x00: Find me deactivated 0x01: Find me activated	Note: Settings are erased when the power is turned off.	
External Input	External Input Status	226 (0xE2)	0	R		UINT	2		bit 00-06: Reserved bit 07: External input status ON: External input On OFF: External input Off bit 08-15: Reserved		
IO-Link	Event Notification Handling	227 (0xE3)	0	R/W	✓	UINT	1	0x00	0x00: All events enabled 0x01: All events disabled 0x02: Events enabled, Process data invalid flag disabled 0x03: Events disabled, Process data invalid flag enabled		
Measurement	Distance to object	229 (0xE5)	0	R			5		Batch access n+0: Measurement status n+1...n+4: Measurement distance		
				1	R		INT	4		Individual access (Measurement distance)	Unit: nm
				2	R		UINT	1	0x00	Individual access (Measurement status) 0x00: Distance in range 0x01: Distance over-run 0x02: Distance under-run 0x03: No distance information	
Display	Display Settings	234 (0xEA)	0	R/W	✓	UINT	5		Batch access n+0: Display language n+1: Turn display n+2, n+3: Energy saving mode n+4: Display brightness		

* R: Read Only, R/W: Read/Write, W: Write Only

Category	Name	Index No. DEC (HEX)	Subindex No.	Read/Write*	Backup	Format	Length in bytes	Default value	Setting Details	Remarks
Display	Display Settings	234 (0xEA)	1	R/W	✓	UINT	1	20	Individual access (Display brightness) 10: 10% 20: 20% 30: 30% 40: 40% 50: 50% 60: 60% 70: 70% 80: 80% 90: 90% 100: 100%	
			2	R/W	✓	UINT	2	20	Individual access (Energy saving mode) 0: OFF 10: 10s 20: 20s 60: 60s 300: 300s 1200 : 1200s 3600: 3600s	
			3	R/W	✓	UINT	1	0x00	Individual access (Turn display) 0x00: 0 degree 0x01: 180 degrees	
			4	R/W	✓	UINT	1	0x01	Individual access (Display language) 0x01: English 0x02: German 0x06: Spanish 0x07: Chinese (Simplified) 0x08: Japanese 0x09: Chinese (Traditional) 0x0A: Korean	
Output Settings	Timer Mode Q1	1085 (0x43D)	0	R/W	✓	UINT	1	0x00	0x00: Deactivated 0x01: T-on delay 0x02: T-off delay 0x03: T-on/T-off delay 0x04: Impulse (One shot)	
	Timer Mode Q2	1086 (0x43E)	0	R/W	✓	UINT	1	0x00	0x00: Deactivated 0x01: T-on delay 0x02: T-off delay 0x03: T-on/T-off delay 0x04: Impulse (One shot)	
	Timer Setup Q1	1087 (0x43F)	0	R/W	✓	UINT	2	1	1-30000	Unit: ms
	Timer Setup Q2	1088 (0x440)	0	R/W	✓	UINT	2	1	1-30000	Unit: ms
External Input	Inverter External Input	1093 (0x445)	0	R/W	✓	UINT	1	0x00	0x00: Not inverted 0x01: Inverted	
Measurement	Analog output value	4359 (0x1107)	0	R		UINT	2	0	Analog output value (value in μ A or mV)	
	Mask Range Settings	4367 (0x110F)	0	R/W	✓	INT	8	Varies by model	n+0...n+3: Mask the far side n+4...n+7: Mask the near side	Setting range on the far side, Unit: nm CD2H-30x: -5040000...5500000 [Default value 5500000] CD2H-50x: -10100000...11000000 [Default value 11000000] CD2H-130x: -70700000...76000000 [Default value 76000000] CD2H-245x: -176750000...189000000 [Default value 189000000] CD2H-350x: -252500000...271000000 [Default value 271000000] CD2H-700x: -505000000...550000000 [Default value 550000000] Setting range on the near side, Unit: nm CD2H-30x: -5040000...5500000 [Default value -5040000] CD2H-50x: -10100000...11000000 [Default value -10100000] CD2H-130x: -70700000...76000000 [Default value -70700000] CD2H-245x: -176750000...189000000 [Default value -176750000] CD2H-350x: -252500000...271000000 [Default value -252500000] CD2H-700x: -505000000...550000000 [Default value -505000000]

* R: Read Only, R/W: Read/Write, W: Write Only

Category	Name	Index No. DEC (HEX)	Subindex No.	Read/Write*	Backup	Format	Length in bytes	Default value	Setting Details	Remarks	
Measurement	Sampling Period	4368 (0x1110)	0	R/W	✓	UINT	2	200 (200 μs)	0: auto 133: 133.3μs 200: 200μs 300: 300μs 500: 500μs 1000: 1ms 2000: 2ms 5000: 5ms		
	Q1 Tolerance	4371 (0x1113)	0	R/W	✓	UINT	4	Varies by model		Setting range, Unit: nm CD2H-30x: 0...5000000 [Default value 1000000] CD2H-50x: 0...10000000 [Default value 1000000] CD2H-130x: 0...70000000 [Default value 2000000] CD2H-245x: 0...175000000 [Default value 4000000] CD2H-350x: 0...250000000 [Default value 4000000] CD2H-700x: 0...500000000 [Default value 4000000]	
	Q2 Tolerance	4372 (0x1114)	0	R/W	✓	UINT	4	Varies by model		Setting range, Unit: nm CD2H-30x: 0...5000000 [Default value 1000000] CD2H-50x: 0...10000000 [Default value 1000000] CD2H-130x: 0...70000000 [Default value 2000000] CD2H-245x: 0...175000000 [Default value 4000000] CD2H-350x: 0...250000000 [Default value 4000000] CD2H-700x: 0...500000000 [Default value 4000000]	
	Moving Average	4373 (0x1115)	0	R/W	✓	UINT	2	0x80	0x01: OFF 0x04: 4 counts 0x08: 8 counts 0x10: 16 counts 0x20: 32 counts 0x40: 64 counts 0x80: 128 counts 0x100: 256 counts 0x200: 512 counts		
	Median Filter	4374 (0x1116)	0	R/W	✓	UINT	2	0x03	0x00: OFF 0x03: 3 counts 0x07: 7 counts 0x0F: 15 counts 0x1F: 31 counts		
	Measurement Direction	4375 (0x1117)	0	R/W	✓	UINT	1	0x00	0x00: Positive 0x01: Negative		
	Measured Value Offset	4376 (0x1118)	0	R/W	✓	INT	4	0	The difference value is stored to set the measurement value to zero by performing Offset. Resetting Offset will set the difference value to zero.	Setting range, Unit: nm CD2H-30x: -5000000...5000000 CD2H-50x: -10000000...10000000 CD2H-130x: -70000000...70000000 CD2H-245x: -175000000...175000000 CD2H-350x: -250000000...250000000 CD2H-700x: -500000000...500000000	
	Error Hold Time	4377 (0x1119)	0	R/W	✓	UINT	4	1	1-100000	Unit: ms	
	Set Clamp Value	4378 (0x111A)	0	R/W	✓	INT	4	2000000000	-2000000000...+2000000000	Unit: nm Sets the value to be displayed/output when measurement is not possible.	
	Error Mode	4379 (0x111B)	0	R/W	✓	UINT	1	0x00	0x00: Clamp value. 0x01: Hold last value 0x02: Hold last value + timer		
	Span Teach		4380 (0x111C)	0	R/W		UINT	17		0x00: ALL	
				1	R/W		UINT	4		0x01: 1st point measured value	
				2	R/W		UINT	4		0x02: 1st point set value	
3				R/W		UINT	4		0x03: 2nd point measured value		
4				R/W		UINT	4		0x04: 2nd point set value		
			5	R/W		UINT	1		0x05: Span teach execution		
Span		4381 (0x111D)	0	R/W		FLOAT	4				

* R: Read Only, R/W: Read/Write, W: Write Only

Category	Name	Index No. DEC (HEX)	Subindex No.	Read/ Write*	Backup	Format	Length in bytes	Default value	Setting Details	Remarks
Error	Error History	4389 (0x1125)	0	R	✓		130		Error history #1 n+0...n+3: Error code (doubleword) n+4...n+7: Sensor operation time when an error occurs (doubleword) n+8...n+11: Laser operation time when an error occurs (doubleword) n+12: Internal temperature when an error occurs (INT,1 byte) Error History #2-10 is the same Format as above.	Up to 10 error histories are retained. When an error occurs more than 10 times, the oldest history is overwritten.
External Input	Input Filter	4400 (0x1130)	0	R/W	✓	UINT	1	0x00	0x00: Disabled 0x01: Enabled	Filter time: 100ms
Identification	Firmware Version	4534 (0x11B6)	0	R		UINT	38		n+0...n+18: Firmware creation date n+19...n+37: Firmware version	
Sensor body interface	Emulate Display	9472 (0x2500)	0	R		STRINGS	120		STRINGS information displayed on the unit. Up to 120 bytes.	
	Emulate ESC Key	9473 (0x2501)	0	W		UINT	1		0x01: Short press 0x02: Long press	
	Emulate OK Key	9474 (0x2502)	0	W		UINT	1		0x01: Short press 0x02: Long press	
	Emulate DOWN Key	9475 (0x2503)	0	W		UINT	1		0x01: Short press 0x02: Long press	
	Emulate UP Key	9476 (0x2504)	0	W		UINT	1		0x01: Short press 0x02: Long press	
	Emulate LED POWER	9477 (0x2505)	0	R		UINT	1		0x00: OFF 0x01: ON	
	Emulate LED Q1	9478 (0x2506)	0	R		UINT	1		0x00: OFF 0x01: ON	
	Emulate LED Q2/QA	9479 (0x2507)	0	R		UINT	1		0x00: OFF 0x01: ON	

* R: Read Only, R/W: Read/Write, W: Write Only

4-4 Process Data Format

With the CD2H series, the content of process input data transmitted via IO-Link communication can be selected from the following ten formats.

* The format of process input data can be switched by using Index 120.

No.	Description		Byte No.	Bit							
				7	6	5	4	3	2	1	0
1	When value of Index 120 is 0 * Default setting	Measurement distance data Q1 (DO1) Q2 (DO2)	n+0	Reserved						Q2	Q1
			n+1	Reserved							
			n+2	Measurement distance data INT Unit: nm							
			n+3								
			n+4								
			n+5								
2	When value of Index 120 is 1	Received light amount Q1 (DO1) Q2 (DO2)	n+0	Reserved						Q2	Q1
			n+1	Reserved							
			n+2								
			n+3								
			n+4	Received light amount Unit: None							
			n+5								
3	When value of Index 120 is 2	Timer value Q1 (DO1) Q2 (DO2)	n+0	Reserved						Q2	Q1
			n+1	Reserved							
			n+2	Timer value Time that output is ON Unit: ms							
			n+3								
			n+4								
			n+5								
4	When value of Index 120 is 3	Q1 Edge Q1 (DO1) Q2 (DO2)	n+0	Reserved						Q2	Q1
			n+1	Reserved							
			n+2	Q1 (DO1) Edge INT Unit: nm							
			n+3								
			n+4								
			n+5								
5	When value of Index 120 is 4	Q2 Edge Q1 (DO1) Q2 (DO2)	n+0	Reserved						Q2	Q1
			n+1	Reserved							
			n+2	Q2 (DO2) Edge INT Unit: nm							
			n+3								
			n+4								
			n+5								
6	When value of index 120 is 5	Measurement distance data (SSP format) Q1 (DO1) Q2 (DO2)	n+0	Reserved						Q2	Q1
			n+1	Unit: nm (nm = 2 ⁻⁹ , so -9=0xFE)							
			n+2	Measurement distance data INT Unit: nm							
			n+3								
			n+4								
			n+5								

No.	Description		Byte No.	Bit							
				7	6	5	4	3	2	1	0
7	When value of index 120 is 6	Received light amount (SSP format) Q1 (DO1) Q2 (DO2)	n+0	Reserved						Q2	Q1
			n+1	Reserved							
			n+2								
			n+3								
			n+4	Measurement light amount Unit: None							
			n+5								
8	When value of index 120 is 7	Timer value (SSP format) Q1 (DO1) Q2 (DO2)	n+0	Reserved						Q2	Q1
			n+1	Reserved							
			n+2	Timer value Time that output is ON Unit: ms							
			n+3								
			n+4								
			n+5								
9	When value of index 120 is 8	Q1 Edge (SSP format) Q1 (DO1) Q2 (DO2)	n+0	Reserved						Q2	Q1
			n+1	Reserved							
			n+2	Q1 (DO1) Edge INT Unit: nm							
			n+3								
			n+4								
			n+5								
10	When value of index 120 is 9	Q2 Edge (SSP format) Q1 (DO1) Q2 (DO2)	n+0	Reserved						Q2	Q1
			n+1	Reserved							
			n+2	Q2 (DO2) Edge INT Unit: nm							
			n+3								
			n+4								
			n+5								

■ Word assignment

Example: When using the IO-Link master of OPTEX FA (default setting: little endian)

Word No.	Byte	
	Higher order byte	Lower order byte
N+0	Process data n+4	Process data n+5
N+1	Process data n+2	Process data n+3
N+2	Process data n+0	Process data n+1

When value of Index 120 is 0

Word No.	Bit															
	15	14	13	12	11	10	9	8	7	6	5	4	3	2	1	0
N+0	Measurement distance data INT Unit: nm															
N+1																
N+2	Reserved						Q2	Q1	Reserved							

4-5 Events and Errors

4-5-1 Events

Code DEC (HEX)	Type	Description
16912 (0x4210)	Warning	Internal temperature +70°C or higher
16928 (0x4220)	Warning	Internal temperature -20°C or lower
30480 (0x7710)	Error	Short-circuit on output line

4-5-2 Errors

Code DEC (HEX)	Additional code DEC (HEX)	Description
128 (0x80)	17 (0x11)	Index not available
	18 (0x12)	Subindex not available
	32 (0x20)	Service temporarily not available
	34 (0x22)	Service temporarily not available - device control
	35 (0x23)	Access denied
	48 (0x30)	Parameter value out of range
	51 (0x33)	Parameter length over-run
	52 (0x34)	Parameter length under-run
	53 (0x35)	Function not available
	54 (0x36)	Function temporarily not available
64 (0x40)	Inconsistent parameter set	

4-6 CD2H_URES_Navigator

This section provides information on the CD2H_URES_Navigator software.

4-6-1 Functions of CD2H_URES_Navigator

- Check the received light waveform of a CD2H connected to the PC.
- Download CD2H received light waveform data to the PC as a CSV file.
 - * When checking received light waveforms with this software, checking outside of the equipment operating hours is recommended due to the process data transfer time delay.
- Simple data logging (on the PC) is possible.
 - * The data logging interval depends on the operating conditions of the PC. Note that logging will not be performed at regular intervals.
- CD2H settings and some device information can be checked or edited (limitations apply).
 - * [Device Information] Model/Serial number/Firmware ver./Internal temperature
 - * [Measurement Settings] Sampling period/Moving average/Median filter
 - * [Q1 Settings] Output mode/Hysteresis value/Threshold value for Output 1 (DO1)
 - * [Q2 Settings] Output mode/Hysteresis value/Threshold value for Output 2/Analog output (DO2/AO)

4-6-2 System configuration for CD2H_URES_Navigator

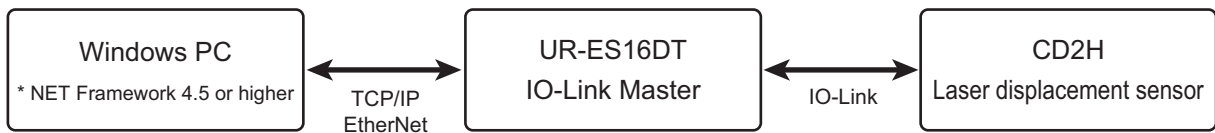

* NET Framework 4.5 is installed as standard on PCs running Windows 7 or higher.

4-6-3 Connecting

■ Settings to configure on the UR-ES16DT

When using the UR-ES16DT, configure the settings as follows to ensure the UR-ES16DT recognizes the CD2H.

1 Access the master parameters menu.

? -2. Master param
↑↓: Select parame

2 Select “Ethernet & Modbus/TCP” for the M2 network type.

M2. Network type
Ethernet & Modbu

3 Set “IO-Link” as the port to which the CD2H is connected under M10 I/O settings.

M10. I/O settings
IO-Link

4 Set the IP address of the UR-ES16DT using the keys and trimmers.

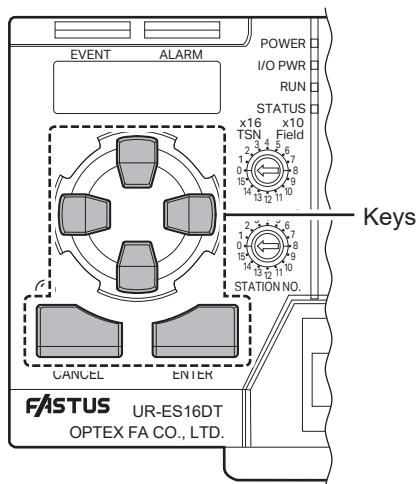

The IP address can be set from the UR-ES16DT's “Master parameter” menu → “M82.IP address.”

The first 3 digits can be edited with the up/down/left/right keys and the CANCEL and ENTER keys.

The last digits can be edited with the dial trimmers on the right side.

Use the lower trimmer to set from 1 to 16 and the upper trimmer to set in multiples of 16.

* For more information, see “M82.IP address” in the UR-ES16DT user's manual common edition.

* The default value for CD2H_URES_Navigator is 192.168.0.1, so setting this to 192.168.0.1 is recommended.

MEMO

The IP address must be set three times.

Set the same IP address on the UR-ES16DT and in the CD2H_URES_Navigator software.

Example:

- UR-ES16DT: 192.168.0.1
- CD2H_URES_Navigator: 192.168.0.1
- PC: 192.168.0.100

■ Settings to configure on the PC

Follow the procedure below to change the IP address of the PC to a fixed IP address (192.168.0.X).

* The example setting screen is for a Windows 10 PC.

- 1** In the Windows search box, type “View network connections” (①), and then click “Open” (②).

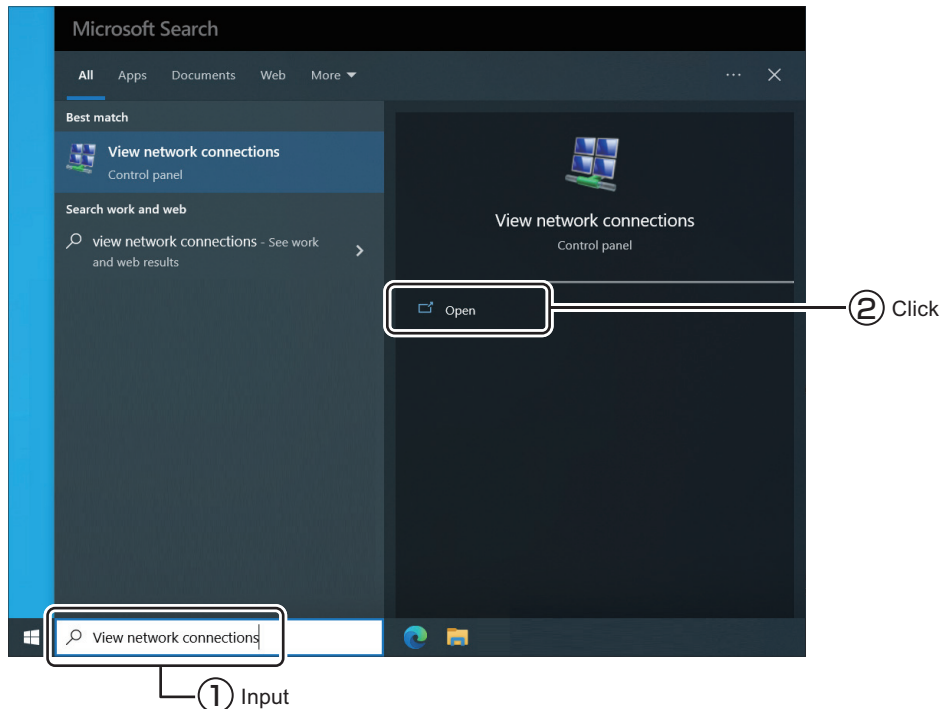

- 2** In the “Network Connections” window, right-click the network adapter to be connected to the UR-ES16DT (①), and from the context menu, click “Properties” (②).

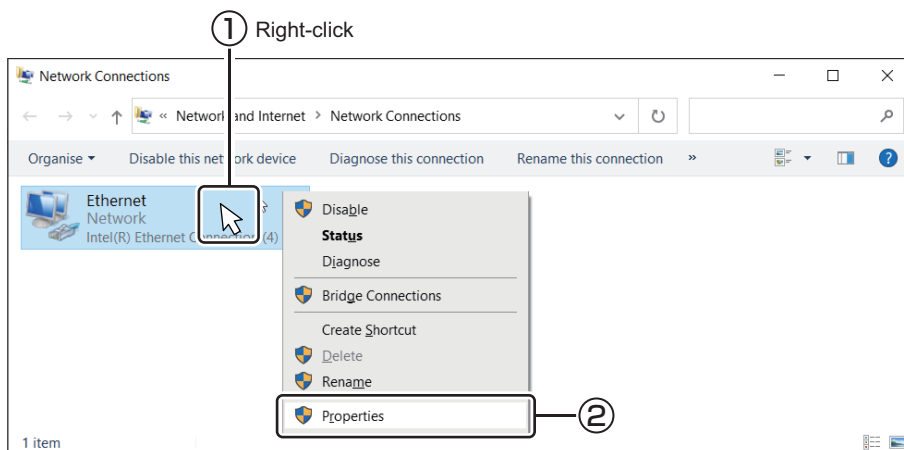

- 3** In the Properties window, select “Internet Protocol Version 4 (TCP/IPv4)” (①), and then click “Properties” (②).

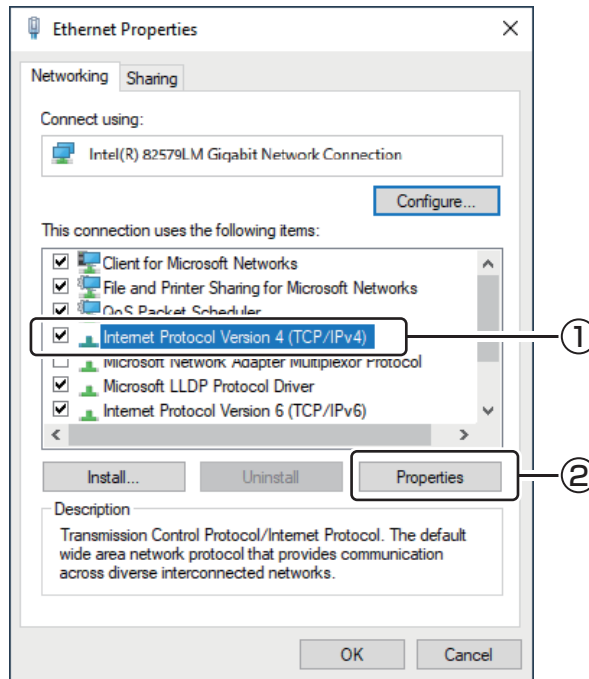

- 4** Select “Use the following IP address,” and enter the IP address (①). Click “OK” (②).
Be sure to set the IP address using the 192.168.0.XX format.
The subnet mask should be 255.255.255.0, and Default gateway should be empty.

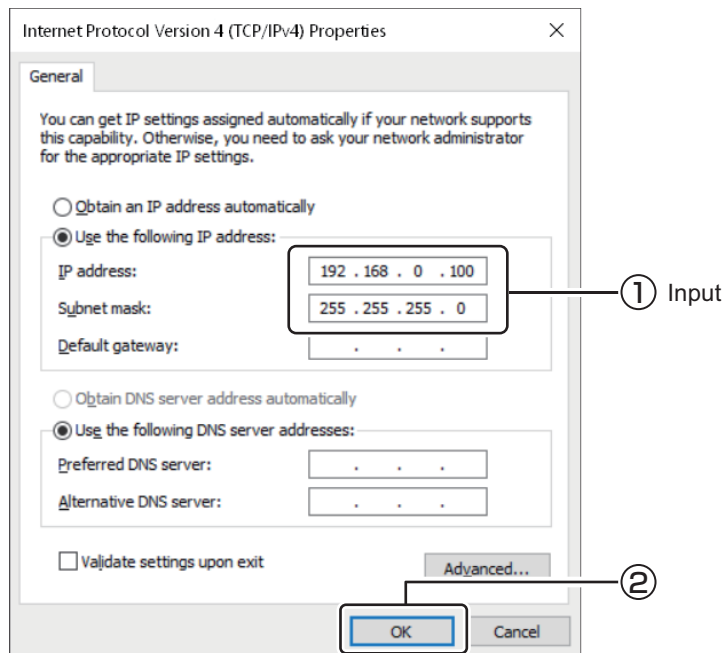

- 5** After configuring the settings, connect the PC and the UR-ES16DT with a LAN cable, and then connect the UR-ES16DT to the CD2H before turning on the power to the UR-ES16DT.

Using CD2H_URES_Navigator

1 Double-click CD2H_URES_Navigator_En.exe to launch the tool.

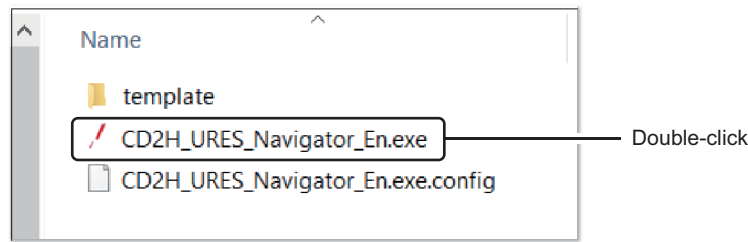

2 After the app starts up, set the device connection port (UR-ES16DT port number where the CD2H is connected) (1) and the IP address (same as the UR-ES16DT), and then click [Connect] (2).

If the connection to the UR-ES16DT is established correctly, [Connect] will turn green and data readout will begin.

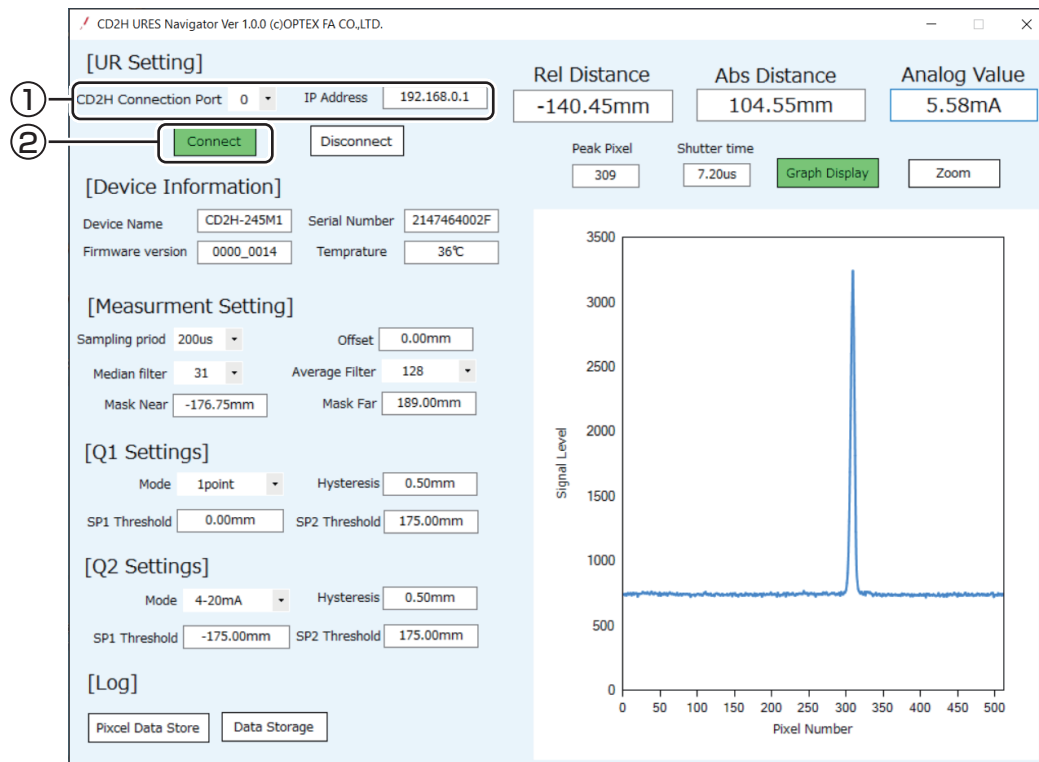

Changing setting values

The settings under Measurement Setting, Q1 Settings, and Q2 Settings can be changed. (Offset and Mask under Measurement Setting cannot be changed.)

For items with a drop-down list, select the setting from the drop-down list. For items with a text box, enter the desired value in the text box directly.

* For items with a text box, be sure to click [Enter] after entering a value. The setting will not be changed unless [Enter] is clicked.

● Received light waveform display

Click [Graph Display] toward the top to show or hide the received light waveform. (Because showing the graph slows down the measured value update cycle, hide the graph to see distance fluctuations.)

Click [Zoom] to switch the display to show only the received light waveform peak area.

The pixel number with the highest received light amount is indicated under Peak Pixel, and the electronic shutter time (sensitivity) of the image sensor is indicated under Shutter time.

● LOG function

Pixel data storage: Click [Pixel Data Store] to read the current received light waveform and save it to an Excel file.

* The Excel file will be saved with the name "Pixel_Datalog_0.xlsx" in the same folder as the .exe file.

Data storage: Click [Data storage] to begin saving the measured values.

Click [Data storage] again to stop saving the measured values. The data will be saved to an Excel file.

* The Excel file will be saved with the name "Distance_Datalog_0.xlsx" in the same folder as the .exe file.

* To ensure the measured values update as rapidly as possible, the graph display will be turned off while data storage is in progress.

* The logging cycle will vary depending on the conditions of the PC. The interval will be between approximately 0.05 to 0.15 seconds.



5

Specifications

This chapter describes the specifications, dimensions, and other characteristics of the product.

5-1 Specifications

5-1-1 Measurement Specifications

Model	Cable	CD2H-30A	CD2H-50A	CD2H-130	CD2H-2452	CD2H-3502	CD2H-7002
	Pigtail cable	CD2H-30M12A	CD2H-50M12A	CD2H-130M12	CD2H-245M122	CD2H-350M122	CD2H-700M122
Center of measurement range		30 mm	50 mm	130 mm	245 mm	350 mm	700 mm
Measurement range		±5 mm	±10 mm	±70 mm	±175 mm	±250 mm	±500 mm
Light source	Medium	Red semiconductor laser					
	Wavelength	655 nm					
	Maximum output	0.39 mW			1 mW		
Laser class	JIS/IEC/FDA*1	CLASS 1			CLASS 2		
Spot size*2		ø50 μm	ø70 μm	ø0.3 mm	ø0.5 mm	ø0.6 mm	ø1.0 mm
Linearity		±0.1% of F.S.					±0.1% of F.S. (200 to 700 mm)/ ±0.3% of F.S. (700 to 1200 mm)
Resolution*3		0.25 μm	0.25 μm	4 μm	10 μm	20 μm	100 μm
Repeat accuracy*4		0.25 μm	0.25 μm	4 μm	10 μm	20 μm	100 μm
Sampling period*5		133.3 μs/150 μs/200 μs/300 μs/500 μs/1 ms/2 ms/5 ms/Auto					
Temperature characteristic*6		±0.06% of F.S./°C					
Weight		Cable model: Approx. 140 g, Pigtail cable model: Approx. 90 g					

5-1-2 Common Specifications

Supply voltage		18 to 24 V DC
Current consumption*7		80 mA (at 18 V DC), 70 mA (at 24 V DC)
IO-Link	Specifications	Rev. 1.1
	Baud rate	COM3 (230.4 kbps)
	Number of process input data bytes	6 bytes
	Minimum cycle time	0.7 ms
Control output (DO1/DO2*8)	No. of outputs	2 (DO1 can be switched to IO-Link.)
	Polarity	NPN/PNP open collector or Push-Pull (selectable by setting) Max. 100 mA / 24 V DC, residual voltage 1.8 V or less
Analog output Q _A *8	Current	4 to 20 mA, load impedance: 300 Ω or less
	Voltage	0 to 10 V, output impedance: 100 Ω or less

External input**9		Switchable between Off, Multi operations, Hold, Zero point teach, and Laser off
Display		0.9-inch OLED display Menu languages: English, German, Spanish, Japanese, Simplified Chinese, Traditional Chinese, Korean
Indicators		Power indicator (green), IO-Link communication indicator (flashing green)/ output indicators (orange × 2)
Connection		Cable: ø4.5 mm 2 m cable Pigtail cable: ø4.5 300 mm cable with M12 5-pin connector Minimum bending radius: Cable diameter × 2 (when fixed in place), cable diameter × 6 (when movable)
Protection circuit		Reverse connection protection, overcurrent protection
Environmental resistance	Degree of protection	IP67 (including M12 connector of pigtail cable model)
	Ambient temperature/humidity	-10 to +50°C/35 to 85%RH (without freezing or condensation)
	Storage temperature/humidity	-20 to +60°C/35 to 85%RH (without freezing or condensation)
	Ambient illuminance	Incandescent light: 10000 lx max., Fluorescent light: 10000 lx max.
	Vibration resistance	Vibration resistance 10 to 55 Hz Double amplitude 1.5 mm, 2 hours in each X, Y, Z direction
	Shock resistance	500 m/s ² (Approx. 50 G) 3 times in each X, Y, Z direction
Applicable regulations	EMC	EU EMC Directive (2014/30/EU), UK EMC (Electromagnetic Compatibility Regulations 2016)
	Environment	RoHS Directive (2011/65/EU), UK RoHS (The Restriction of the Use of Certain Hazardous Substances in Electrical and Electronic Equipment Regulations 2012), China RoHS (MIIT Order No. 32)
	Safety	FDA Regulations (21 CFR 1040.10 and 1040.11)*10
Applicable standards		EN 60947-5-2, IEC 60825-1
NRTL certification		UL Recognized Components Proximity Switch Certified for US and Canada.
Company standards		Noise resistance: Feilen Level 3 cleared
Warm-up time		Approx. 30 minutes
Material		Housing: PBT, Front window: PMMA

● Measurement condition

The measurement conditions are as follows unless otherwise designated:

Ambient temperature: 25°C (room temperature); supply voltage: 24 VDC; sampling period: 200 µs; moving average performed: 128; median filter: 31; center of measurement range, standard measured object (white ceramic). Furthermore, the sensor is fixed in place with an aluminum bracket when measurements are performed.

*1: In accordance with the FDA provisions of Laser Notice No. 56, the laser is classified per the IEC 60825-1:2014 standard.

*2: Defined with center strength $1/e^2$ (13.5%) at the center of the measurement range. There may be leak light other than the specified spot size. The sensor may be affected when there is a highly reflective object close to the detection area.

*3: The smallest determinable step when changing the distance between the sensor and the target one step at a time (at moving average of 512)

- *4: Peak to peak value of measurement in stationary state (at moving average of 512)
- *5: Set to 200 μ s by default.
- *6: Typical example when the object (white ceramic) is measured while the object and the sensor are fixed in place with aluminum brackets. This object is placed at the center of the measurement range.
- *7: Value when DO2 is set to analog output (current) and measurement is not possible (outputting a current of 21 mA).
- *8: Set to analog current output by default.
- *9: Set to laser off by default.
- *10: Excluding differences per Laser Notice No. 56.

5-2 Dimensions

■ Cable model

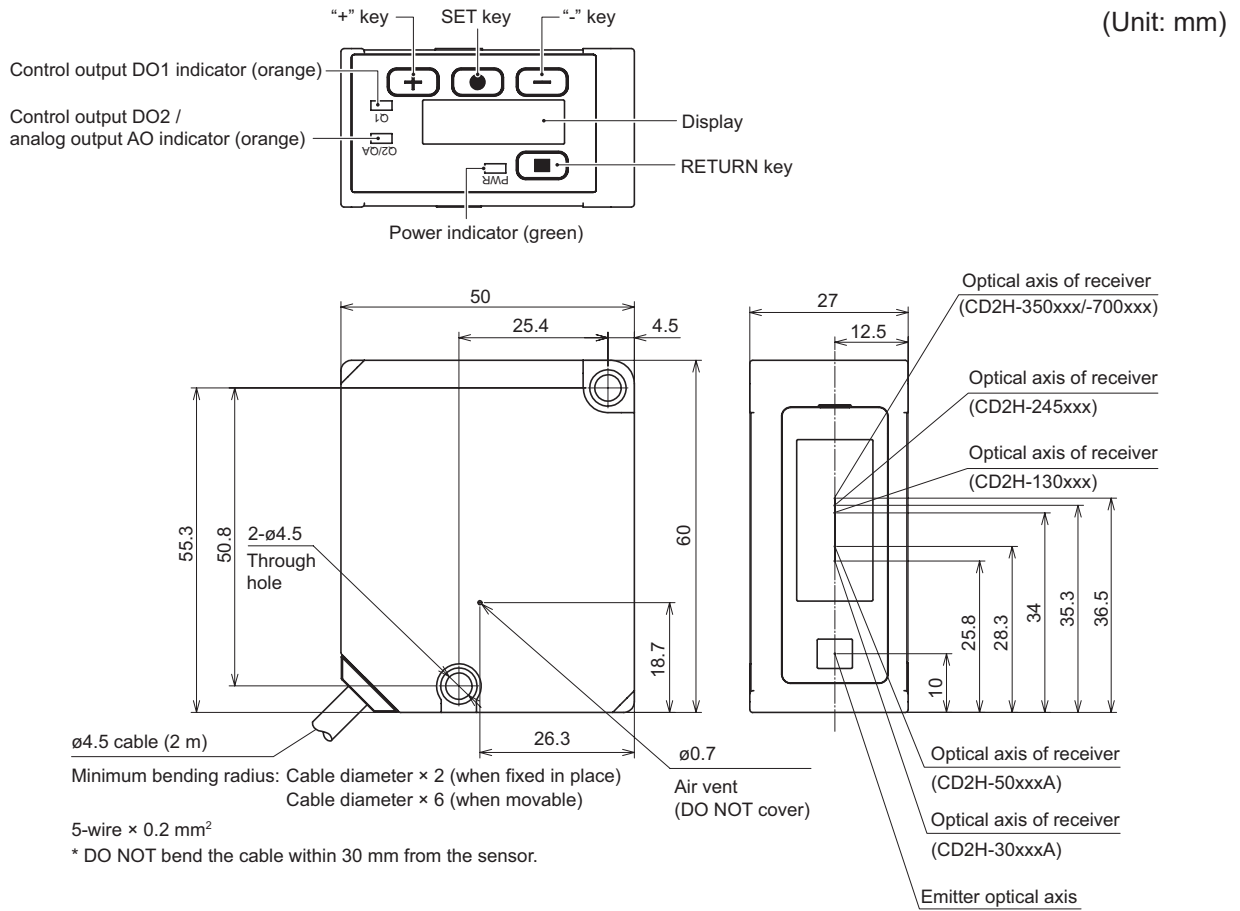

■ Pigtail cable model

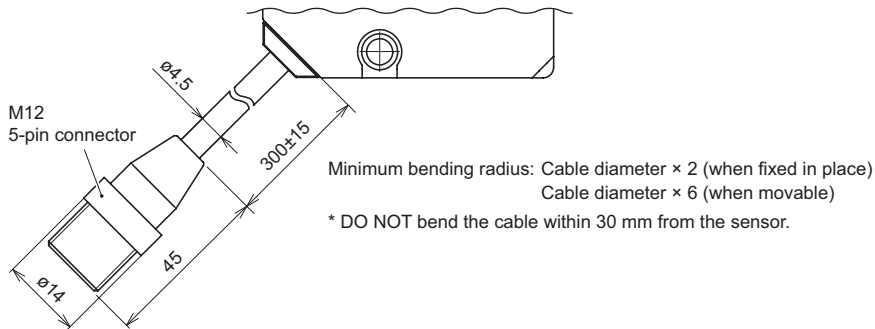

■ M12 5-pin connector cables (straight, open-end)

- YF2A15-020VB5XLEAX
- YF2A15-050VB5XLEAX
- YF2A15-100VB5XLEAX

Cable material: PVC, Conductor cross-section: 5-wire × 0.34 mm²
 L = 2000 (YF2A15-020VB5XLEAX)
 = 5000 (YF2A15-050VB5XLEAX)
 = 10000 (YF2A15-100VB5XLEAX)

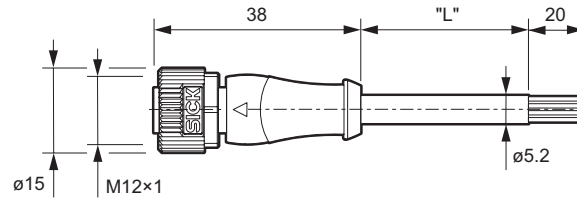

■ M12 5-pin connector cables (straight, open-end, bending resistant)

- DOL-1205-G02M-R
- DOL-1205-G05M-R

Cable material: PVC, Conductor cross-section: 5-wire × 0.3 mm²
 L = 2000 (DOL-1205-G02M-R)
 = 5000 (DOL-1205-G05M-R)

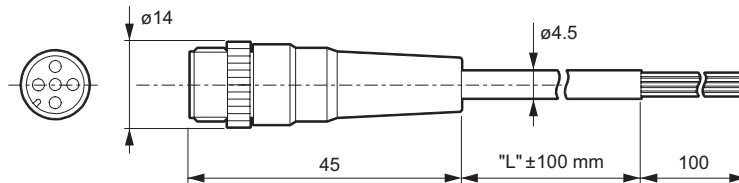

■ Mounting bracket (optional)

- BEF-WN-OD2000-B

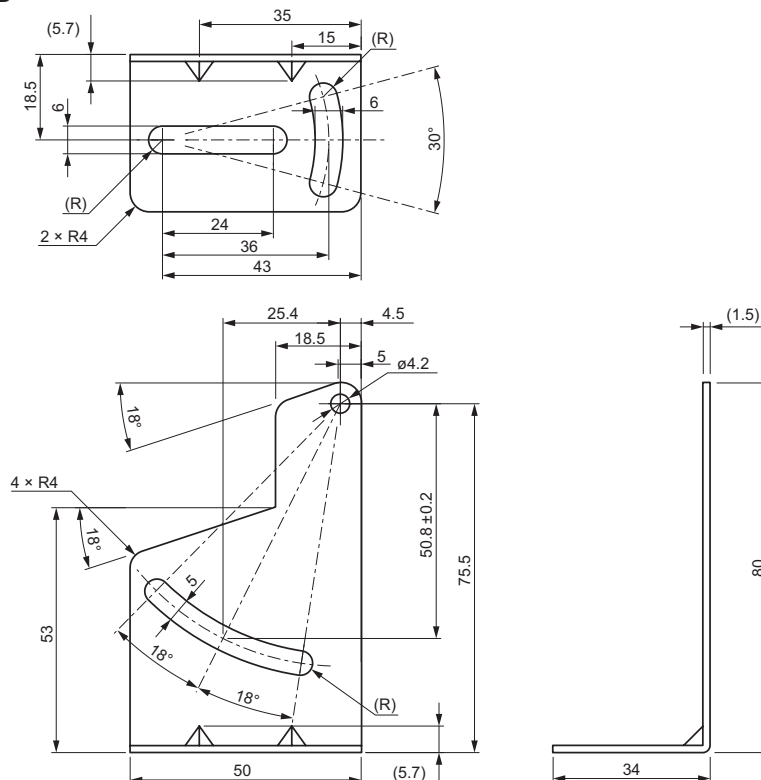

5-3 Typical Characteristics

5-3-1 Spot Size

■ CD2H-30xxxA

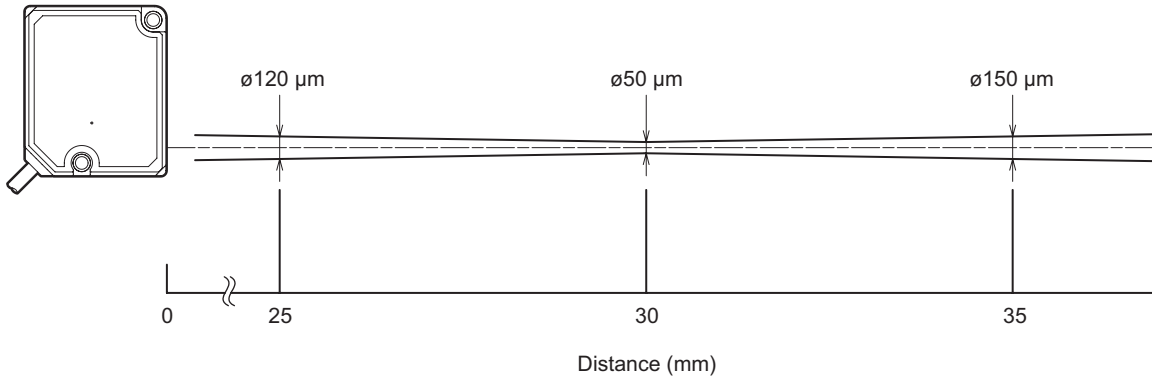

■ CD2H-50xxxA

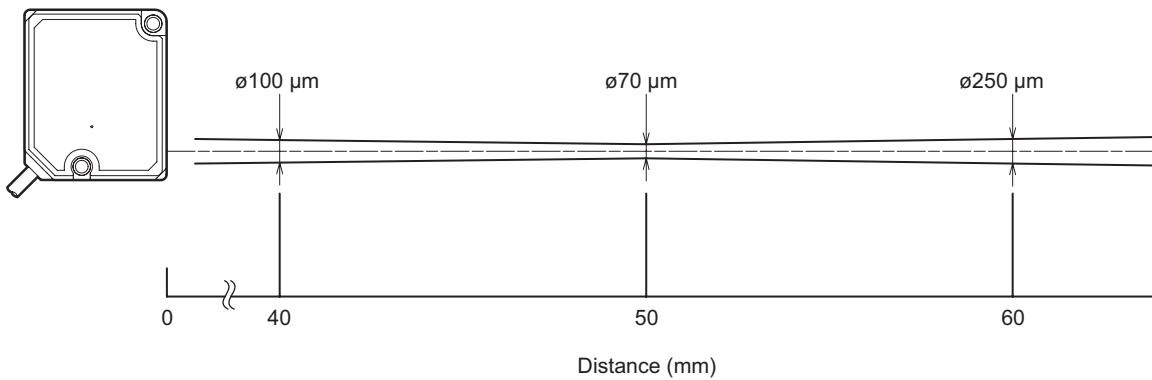

■ CD2H-130xxx

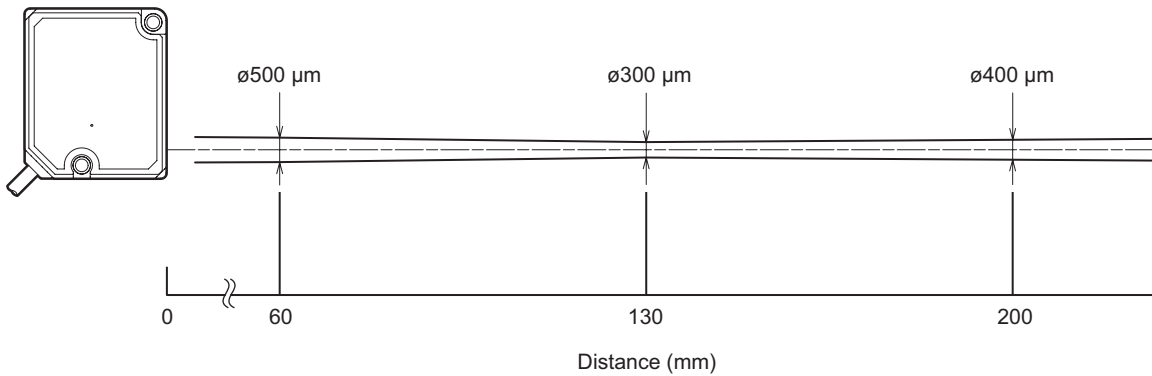

■ CD2H-245xxx

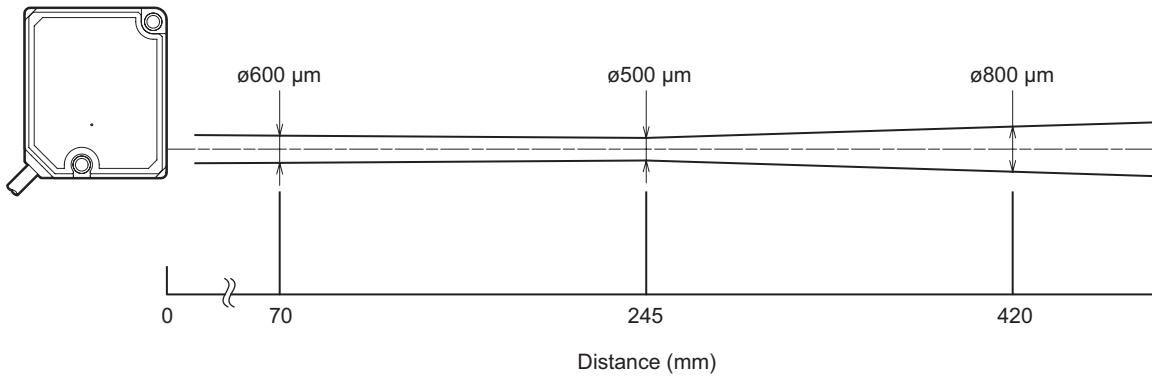

■ CD2H-350xxx

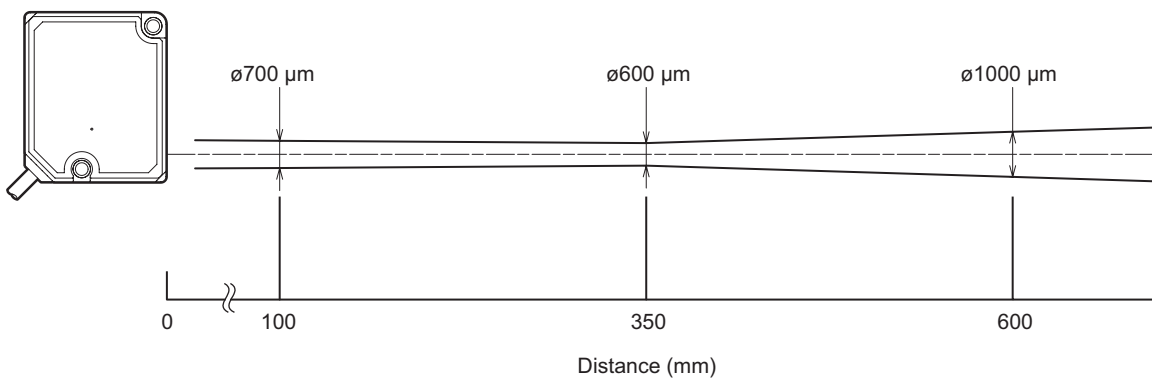

■ CD2H-700xxx

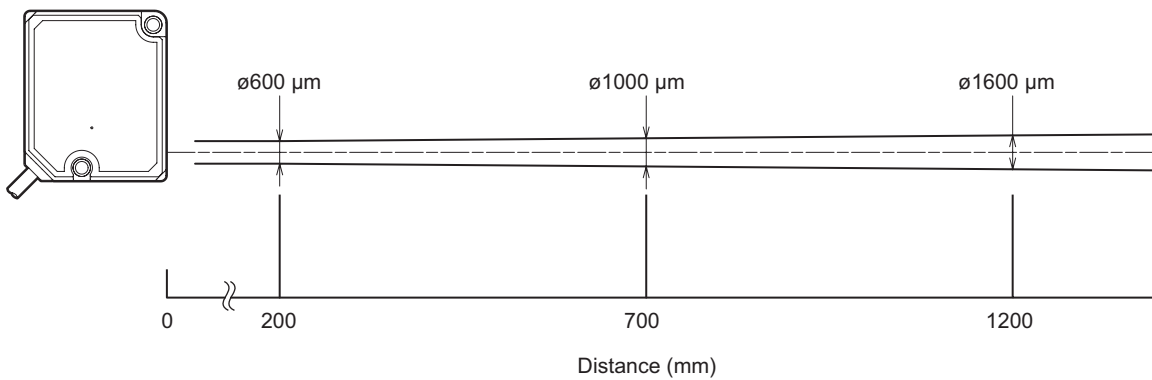

5-3-2 Interference Area

■ CD2H-30xxxA

(Unit: mm)

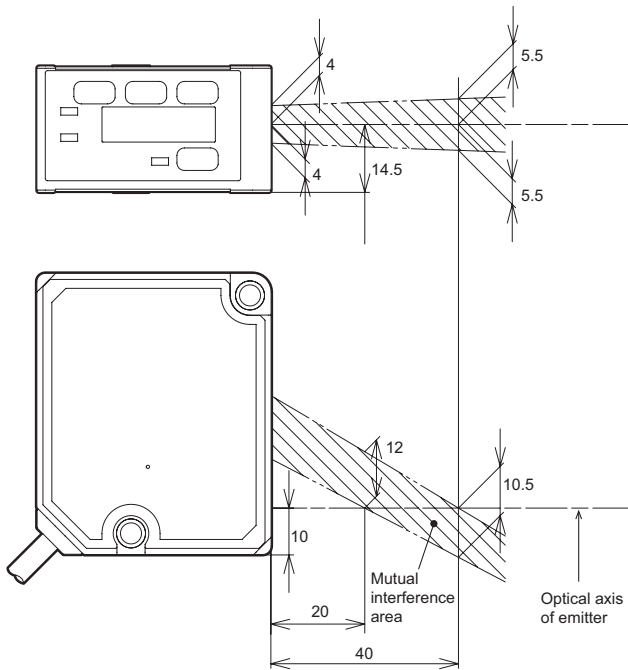

■ CD2H-50xxxA

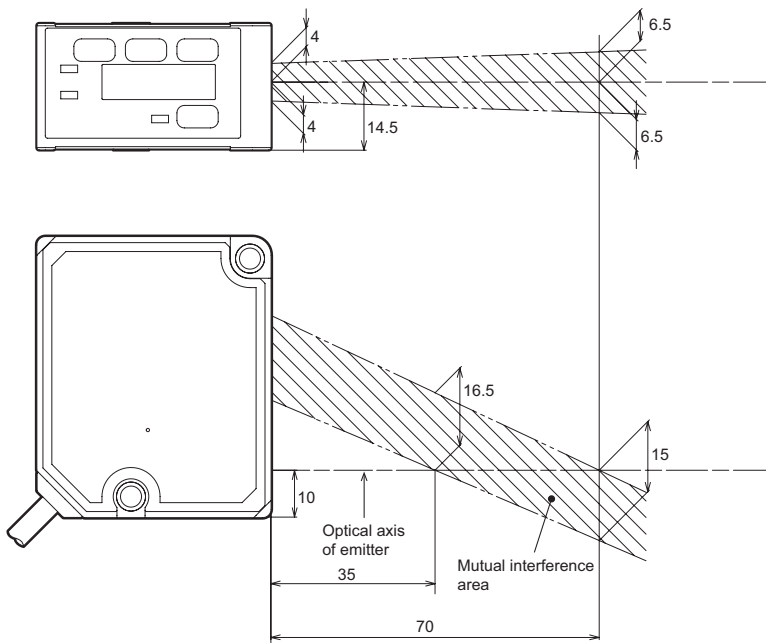

■ CD2H-130xxx

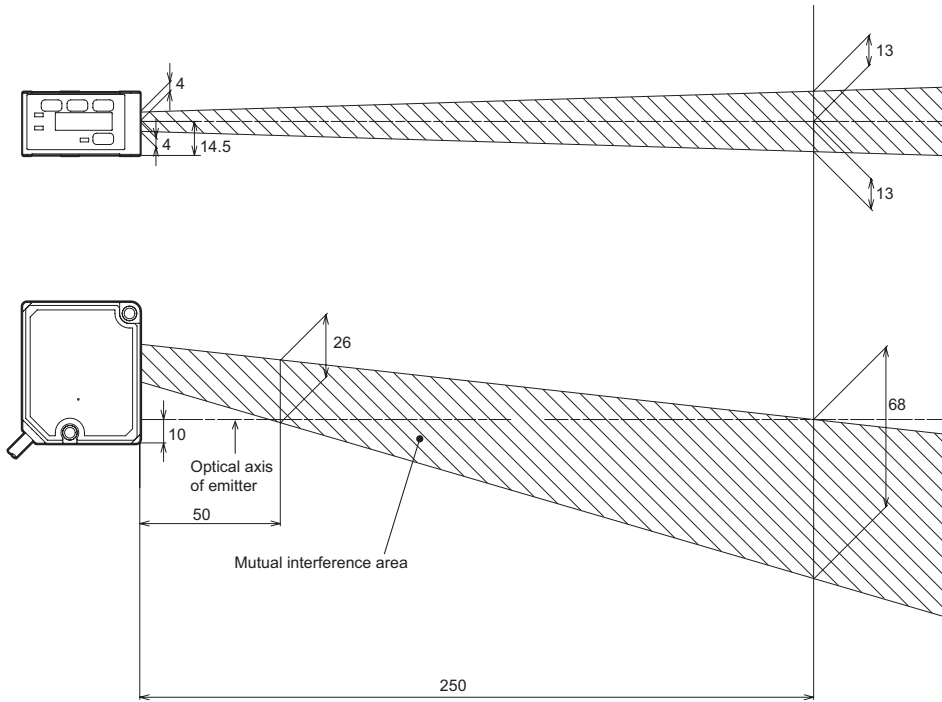

■ CD2H-245xxx

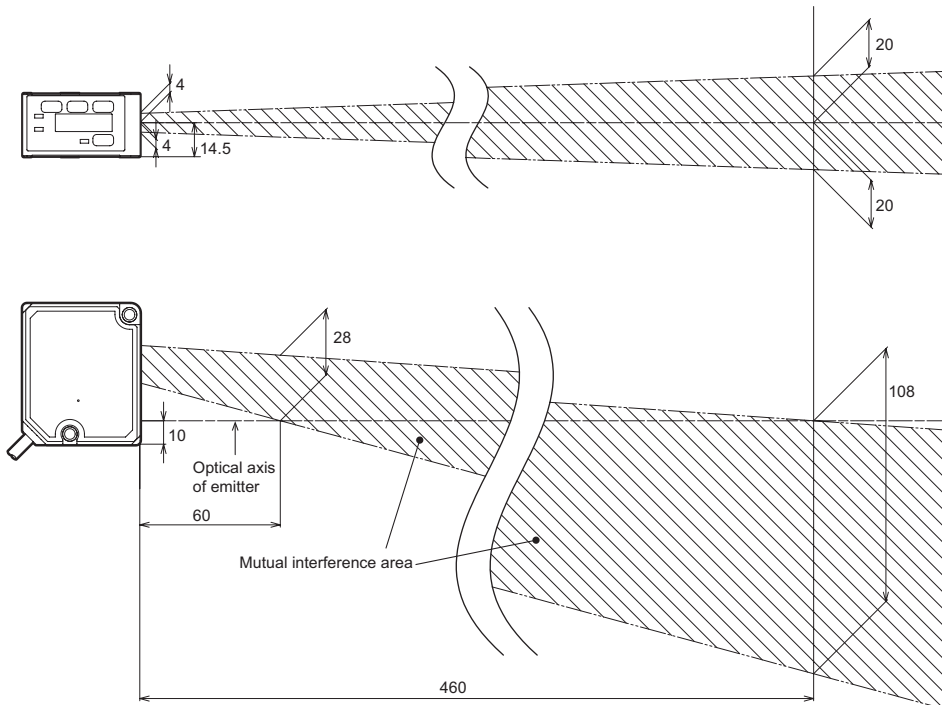

■ CD2H-350xxx

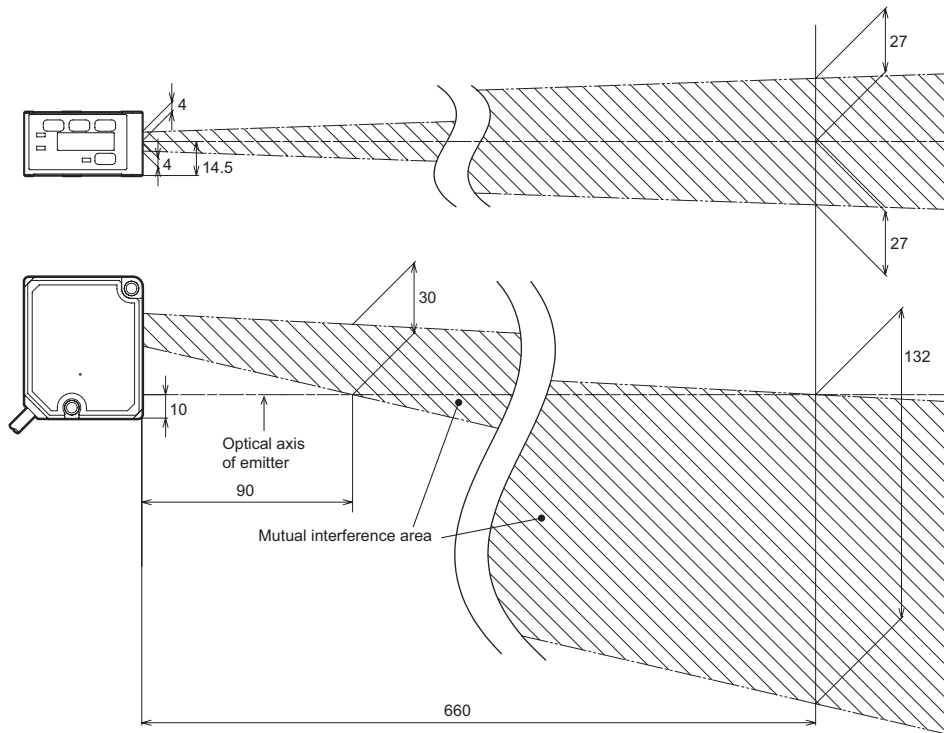

■ CD2H-700xxx

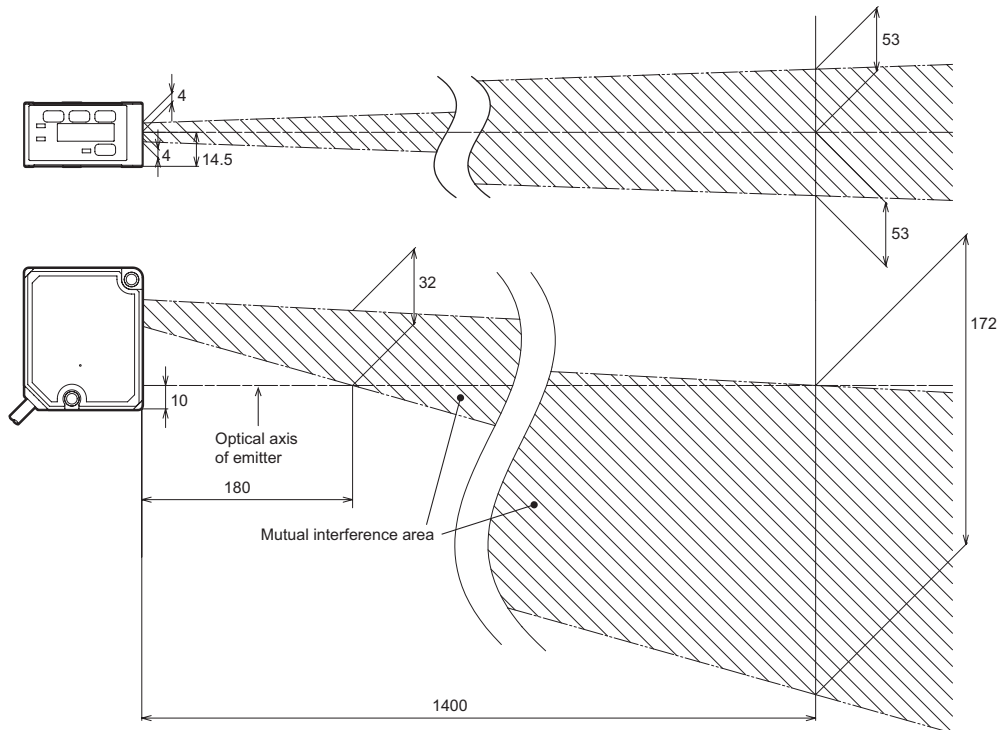

5-3-3 Light Axis Area

■ CD2H-30xxxA

(Unit: mm)

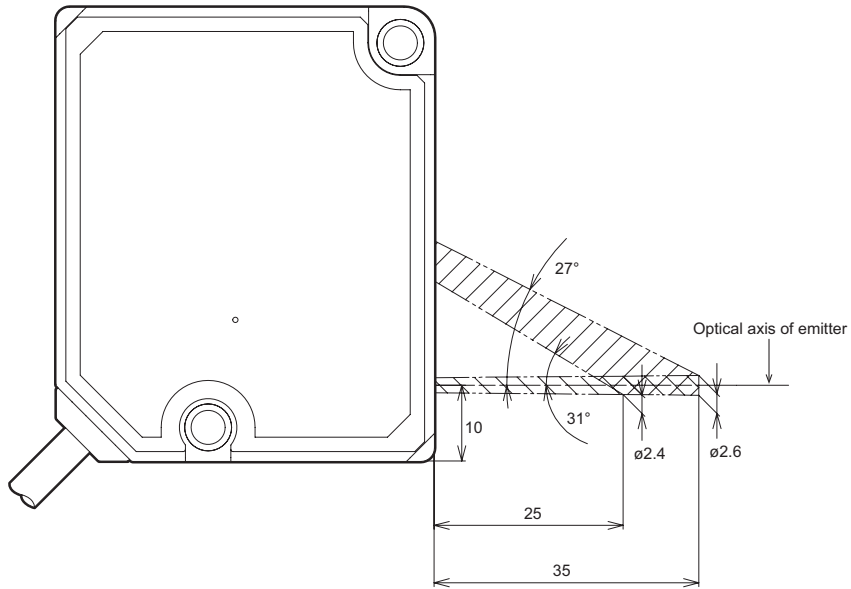

■ CD2H-50xxxA

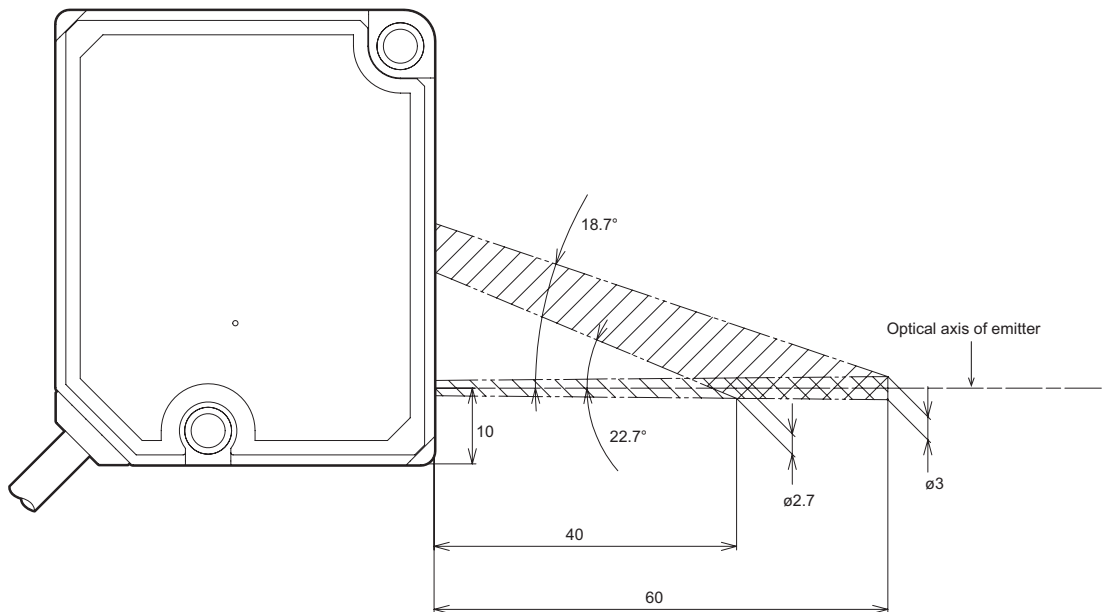

CD2H-130xxx

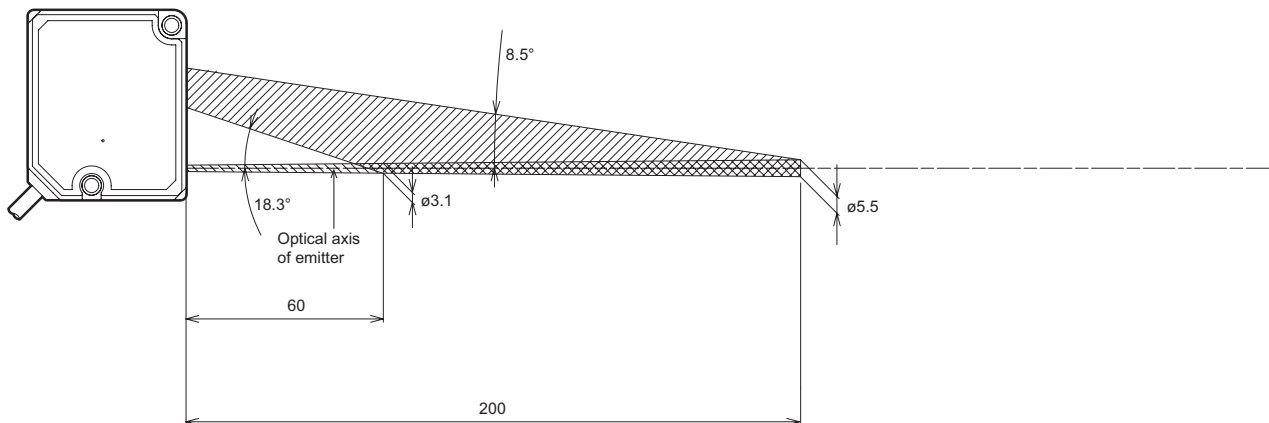

CD2H-245xxx

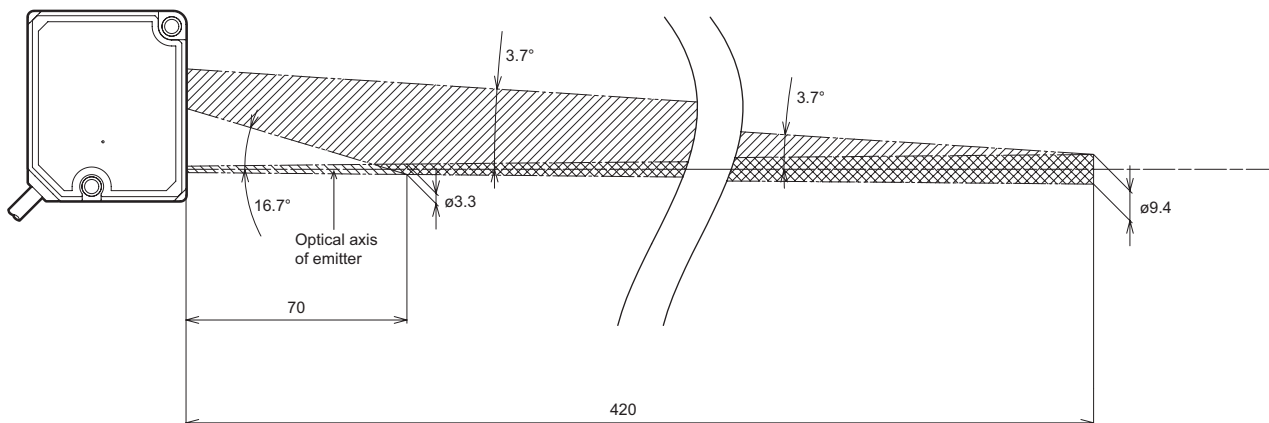

CD2H-350xxx

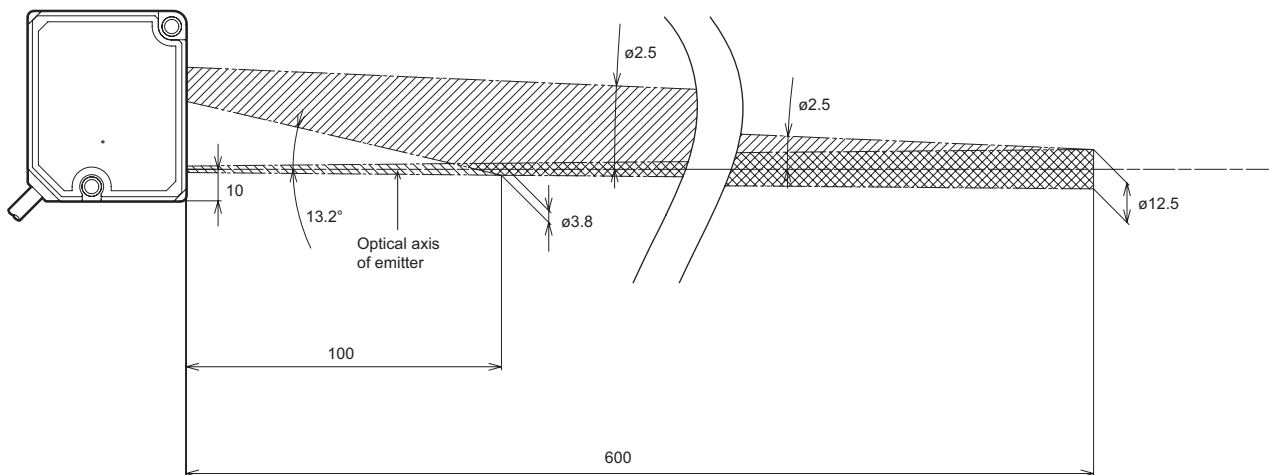

CD2H-700xxx

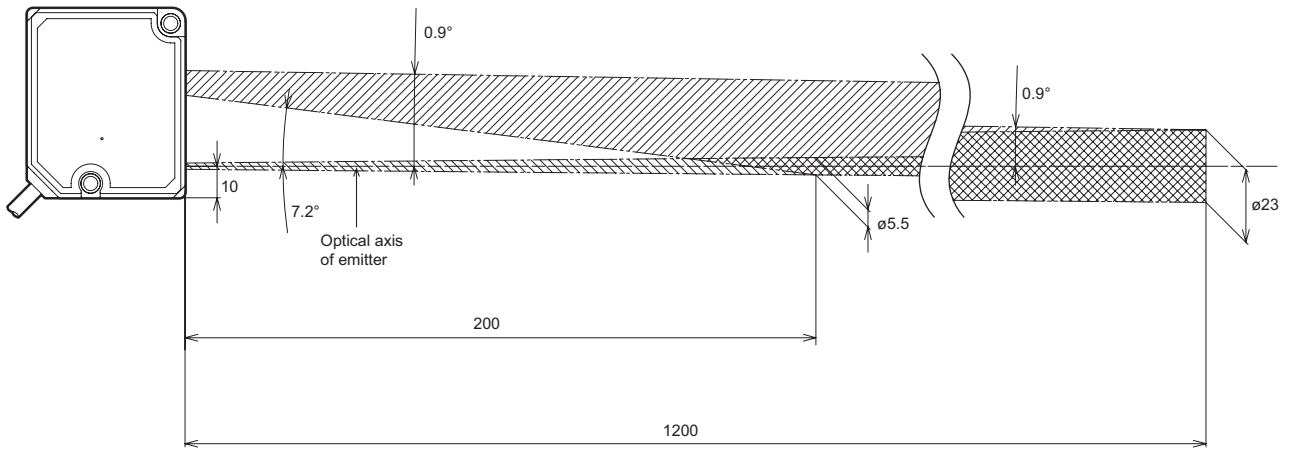



6

Troubleshooting

This chapter describes the causes of and remedies for problems that may arise during use.

6-1 Troubleshooting

■ Operation is unstable with measurement repeatedly switching between possible and impossible

The sampling period may be too short and the received light amount is insufficient. (See “3-1-2 [A1] Sampling period” (page 3-3).)

Increase the received light amount by setting a longer sampling period.

- Set a longer sampling period or change the setting to Auto.

Due to the characteristics of light, attenuation occurs with the square of the distance.

At a distance of 100 mm: $1/(100 \times 100) = 1/10000$

At a distance of 1000 mm: $1/(1000 \times 1000) = 1/1000000$

If the measurement distance is 10 times longer, the received light amount is attenuated to 1/100.

Black absorbs light.

The reflected light amount from black is about 1/10 less than from white.

For extremely shiny objects (such as specular surfaces), the emitted laser light will be directly reflected and will not be received by the receiving element.

● Diffuse reflective

The beam is emitted perpendicular to the measurement surface and, from the reflected light, the diffusely reflected light is received.

This makes it possible to obtain measurements over a wide range.

This method is not suitable for transparent objects and specular objects, which generate almost no diffuse reflections.

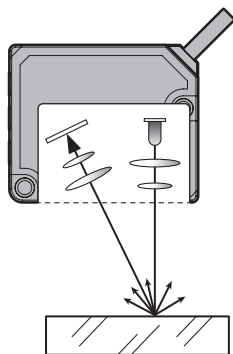

If the laser light is emitted at a right angle to a specular surface, the reflected light will return to the emitting element and will not be received by the receiving element.

The sensor uses diffuse reflective detection, so it is not suitable for measuring specular surfaces or transparent objects with little or no diffuse reflection.

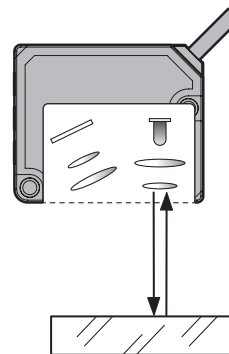

With a direct reflection, no light will be received by the receiving element.

For glossy surfaces, increased glossiness will result in a stronger specular reflection and weaker diffuse reflection.

For objects with glossy surfaces, the same countermeasures as for black objects must be taken.

- Check the received light waveform. (See “Measured Value Display (Bar)” (page 2-3 and page 2-7).)
- If the received light waveform level is low, set a longer sampling period or change the setting to Auto.
- Reduce the distance between the sensor and measured object if possible.
- If the received light cannot be stabilized through the above measures, tilt the sensor so that the light can be received through specular reflection.

(When tilting the sensor, the laser spot position will change accordingly.)

(Linearity is reduced when tilting the sensor, so confirm that repeatability can be maintained.)

■ Significant variations in measured values

Measured values may vary when measuring objects in motion.

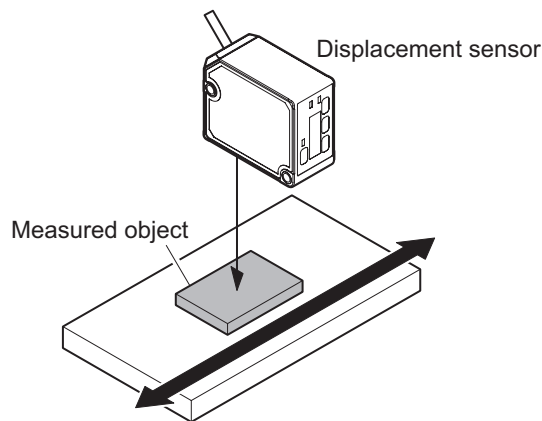

● Reducing variations

- Use median filtering. (See “[A3] Median filter” (page 3-5).)

The median value from the set number of measurements will be set as the measured value.

The response time delay will be the sampling period multiplied by the number of measurements to perform for median filtering.

The data update cycle will become the set sampling period.
- Use moving average filtering. (See “[A2] Moving average” (page 3-4).)

The average value of the specified number of measurements will be set as the measured value.

The response time delay will be the sampling period multiplied by the number of measurements to perform for the moving average.

The data update cycle will become the set sampling period.

■ Chattering in the control output (repeatedly turning ON/OFF quickly)

● Preventing chattering

- Significantly change the hysteresis value. (See “[B19] DO1 Hysteresis” (page 3-27).)
- Use the On delay timer. (See “[B17] DO1 Delay timer” (page 3-25), “[B18] DO1 Timer set” (page 3-26).)

■ Measurement is performed within the measurement range, but the analog output is outside the measurement range

- (1) The object being measured is within the mask setting range. (See “[A11] Mask near / [A12] Mask far” (page 3-11).)
- (2) The measured value is outside the analog output range due to an offset being applied. (See “Relationship between offset and analog output range” (page 3-32).)

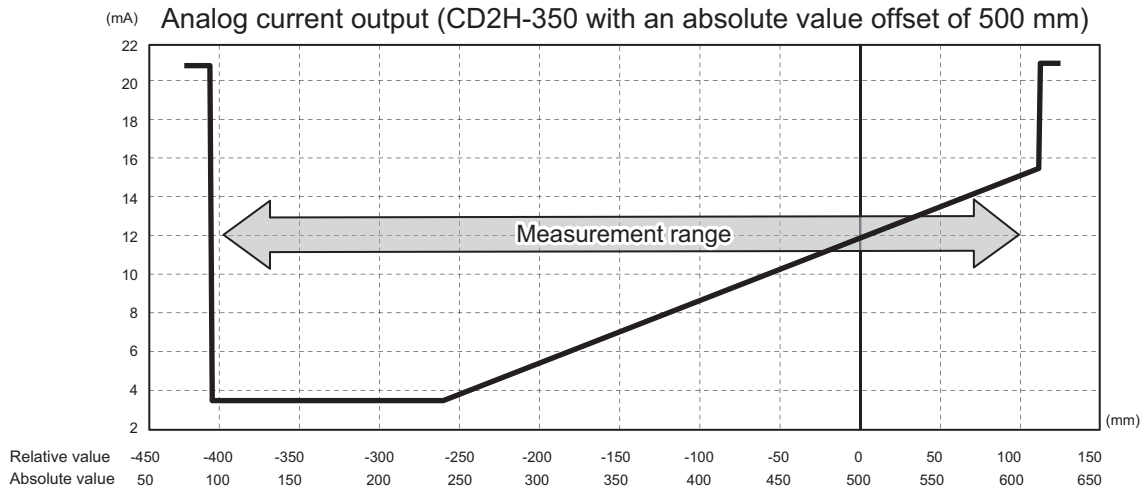

- (3) Measurement is being performed outside the analog output setting range. (See “Relationship between analog output range setting and analog output” (page 3-33).)

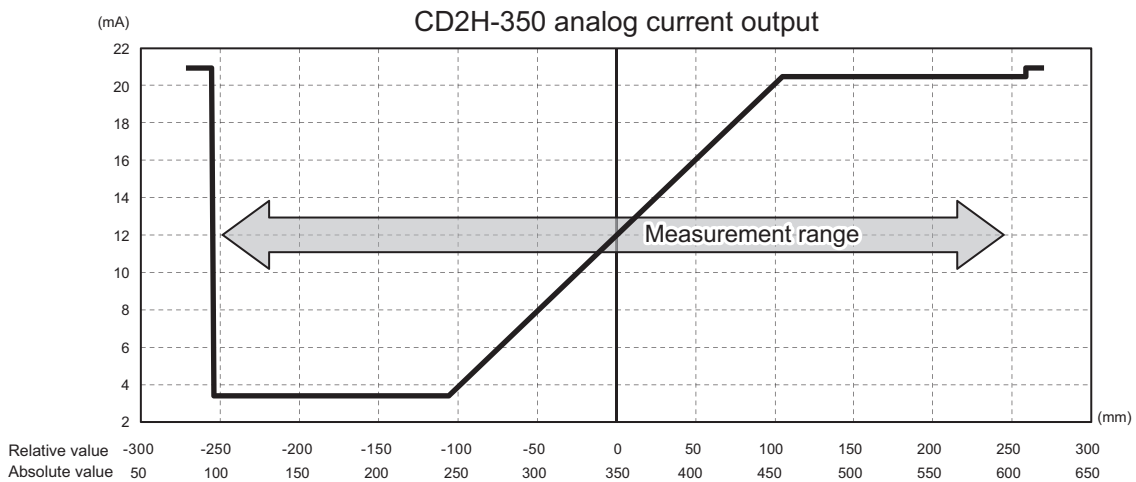

■ No control output

- The input may not be accepted by the PLC if the output time is very short. In some cases, certain settings may cause the output response to be 1 ms or less. (See “* Control output response time according to sampling period and moving average setting” (page 3-4).) Use a one-shot timer in such situations. (See “[B17] DO1 Delay timer” (page 3-25), “[B18] DO1 Timer set” (page 3-26).)
- Hysteresis is too large Set the hysteresis to a small setting, and if the effect is too small, gradually increase the value. (See “[B16] DO1 Output mode” (page 3-24), “[B19] DO1 Hysteresis” (page 3-27).)

■ Deviations occur in measured values

- (1) Offsetting (zero point teaching) is performed with a ceramic gauge
- (2) When the actual measured object (metal surface) is then measured, the measured value deviation is greater than the linearity.

To ensure better use, the reference master should be of the same material and surface conditions as the actual measured object.

Laser displacement sensors are affected by object surface conditions.

* The CD2H is equipped with an automatic sensitivity compensation function and a high-sensitivity receiver element (ATMOS image sensor).

Although these factors help ensure stable measurement and higher resolution, errors cannot be completely eliminated when object surface conditions or material changes.

- Different colors have different reflectance (black: low reflectance, white: high reflectance).
- Different glossy surfaces can have different reflection intensities (high gloss: strong specular reflection, low gloss: strong diffuse reflection).
- Different materials have different degrees of light penetration (metallic materials: no light penetration; resin materials: light penetration differs depending on the surface).

If the measured object material is different from the reference master, the measured values of the actual measured object may differ.

The closer the reference master is to the material and surface conditions of the actual measured objects, the more accurate the actual measurements tend to be.

© The following are CD2H received light waveform examples for different materials.

(Waveforms obtained using a UR-ES16DT and the CD2H_UR-ES_Navigator software.)

- Although the examples do not show all surface conditions, they can still be used to check received light conditions.
- The light penetration condition and other factors can be checked.

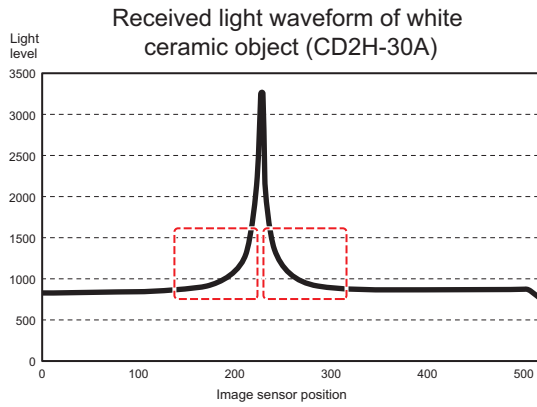

The received light waveform widens on the fringes, indicating that the laser light penetrated the object.

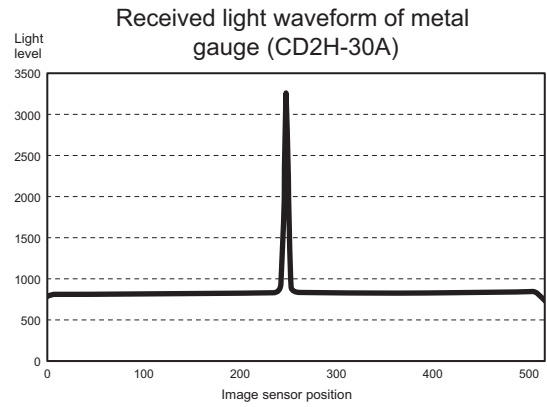

The received light waveform has no widening on the fringes, indicating that the laser light does not penetrate the object.

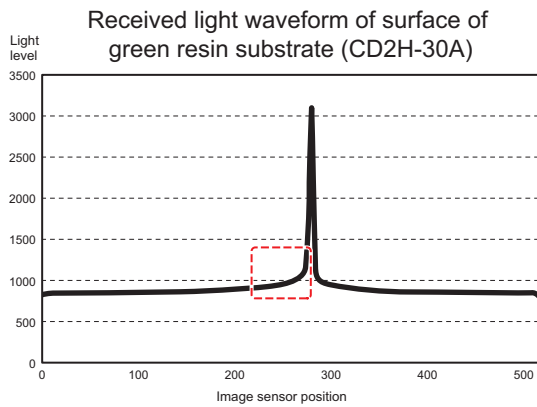

The received light waveform widens slightly on the fringes, indicating that the laser light penetrated the object asymmetrically.

- * The white ceramic used by OPTEX FA as a reference material is a special non-transparent material that allows minimal light penetration. In some cases, measurement of other materials may result in linearity deviations.
- * Before purchasing, testing in the actual measurement environment by installing on the actual machine/device is recommended.



Menu Tree

This chapter describes menu transitions by key operation and the reference pages.

Setting mode menu tree

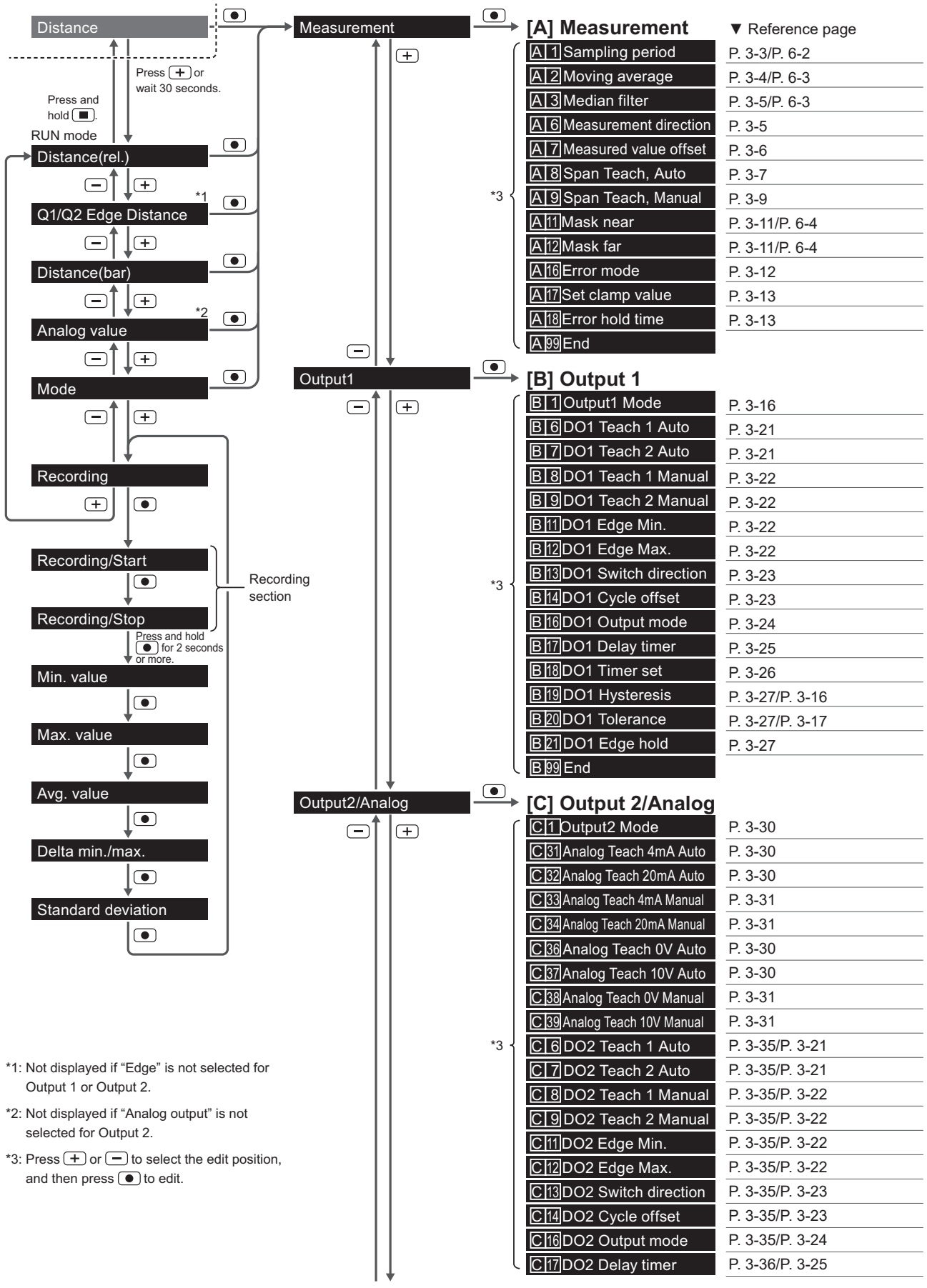

*1: Not displayed if "Edge" is not selected for Output 1 or Output 2.
 *2: Not displayed if "Analog output" is not selected for Output 2.
 *3: Press (+) or (-) to select the edit position, and then press [Enter] to edit.

Continued on next page

Quick set menu tree

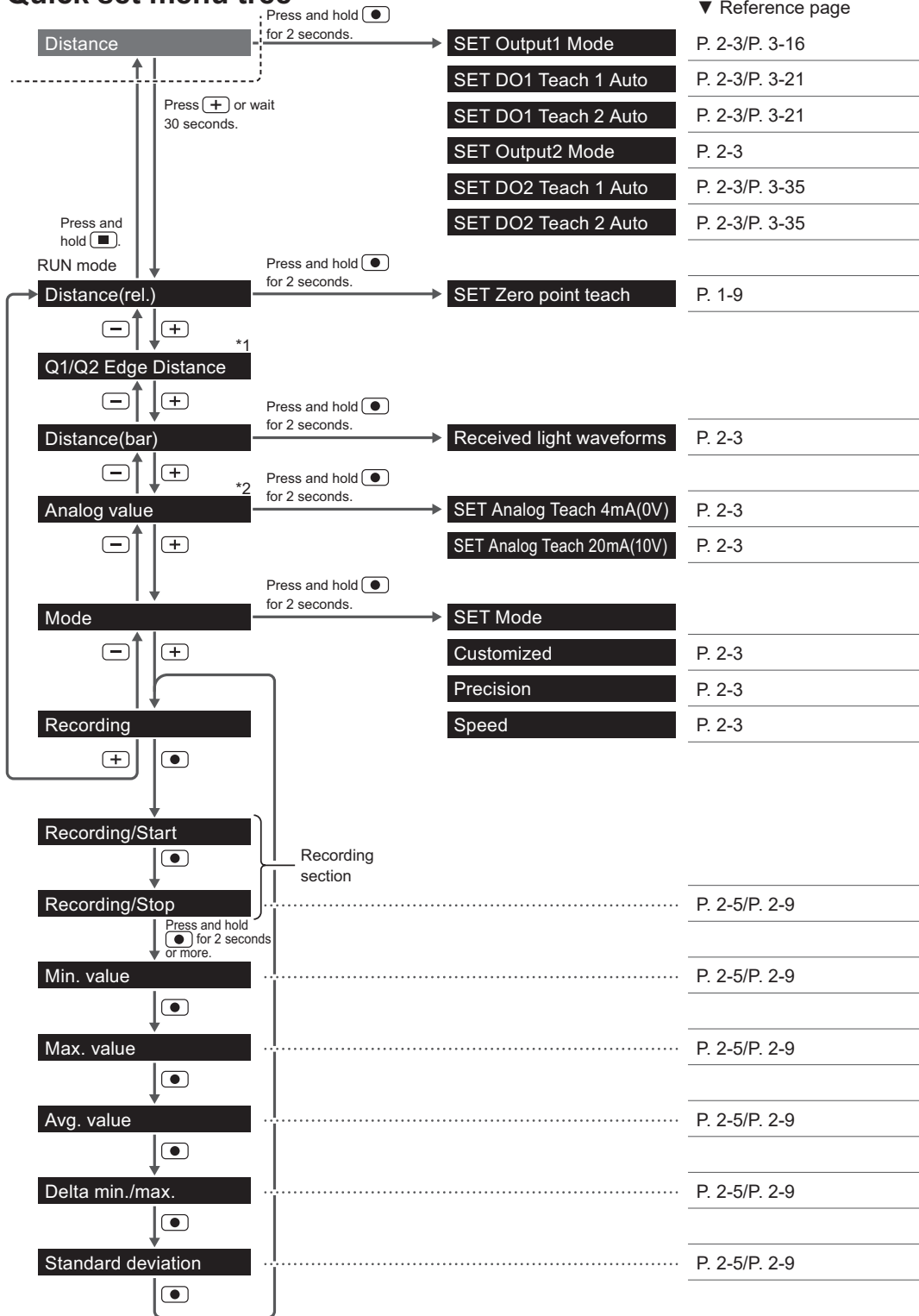

*1: Not displayed if "Edge" is not selected for Output 1 or Output 2. If "Edge" is selected for both Output 1 and Output 2, press the key to switch between the DO1 and DO2 displays.

*2: Not displayed if "Analog output" is not selected for Output 2.

Index

A

Analog Teach 0V Auto	3-30
Analog Teach 0V Manual.....	3-31
Analog Teach 4mA Auto	3-30
Analog Teach 4mA Manual.....	3-31
Analog Teach 10V Auto	3-30
Analog Teach 10V Manual.....	3-31
Analog Teach 20mA Auto	3-30
Analog Teach 20mA Manual.....	3-31
Analog value.....	2-8
Arrow icon.....	2-10
Auto lowest value	3-43
Automatic device parameter backup	4-6
Auto peak value.....	3-43
Average value.....	3-44

B

Backup.....	4-6
-------------	-----

C

CD2H_URES_Navigator	4-23
Chattering	6-3
Clamp value.....	3-12

D

Device.....	3-46
Device identification display	4-7
Diffuse reflective	6-2
Dimensions.....	5-5
Display brightness	3-48
Display off time	3-48
Distance(rel.)	2-2
DO1 1 point	3-16
DO1 Cycle offset	3-23
DO1 Delay timer	3-25
DO1 Edge.....	3-18
DO1 Edge hold.....	3-27
DO1 Edge Max.....	3-22
DO1 Edge Min.....	3-22
DO1 FGS2.....	3-17
DO1 Hysteresis	3-27

DO1 Light level error	3-17
DO1 No measurement.....	3-17
DO1 Output mode	3-24
DO1 Switch direction	3-23
DO1 Teach 1 Auto	3-21
DO1 Teach 1 Manual.....	3-22
DO1 Teach 2 Auto	3-21
DO1 Teach 2 Manual.....	3-22
DO1 Timer set	3-26
DO1 Tolerance.....	3-27
DO1 Zone	3-16
DO2 Cycle offset	3-35
DO2 Delay timer	3-36
DO2 Edge hold.....	3-36
DO2 Edge Max.....	3-35
DO2 Edge Min.....	3-35
DO2 Hysteresis	3-36
DO2 Output mode	3-35
DO2 Switch direction	3-35
DO2 Teach 1 Auto	3-35
DO2 Teach 1 Manual.....	3-35
DO2 Teach 2 Auto	3-35
DO2 Teach 2 Manual.....	3-35
DO2 Timer set	3-36
DO2 Tolerance.....	3-36

E

Edge measurement value.....	3-18
Error count.....	3-51
Error history	3-52
Error hold time	3-13
Error mode.....	3-12
Errors.....	4-22
Events.....	4-22

F

Far On	3-24
Firmware version	3-51

H

Hold last value	3-12
-----------------------	------

Hold last value + timer 3-12

I

Index list 4-11

Information..... 3-50

Initial Setting 1-8

Input..... 3-38

Input delay 3-45

Input Function..... 3-39

Input mode..... 3-45

Interference area 5-9

Internal temperature 3-51

IO-Link Master UR Series..... 4-2

L

Language..... 3-48

Laser..... 3-49

Laser off..... 3-40, 3-49

Laser operating hours..... 3-51

Light axis area 5-12

LOCKED..... 2-10

Lock icon 2-10

Lowest value..... 3-42

M

Mask far..... 3-11

Mask near..... 3-11

Master parameters display 4-5

Measured value..... 3-41

Measured value display (absolute value) 2-6

Measured value display (bar) 2-7

Measured value display (relative value) 2-5

Measured value offset 3-6

Measurement..... 3-2

Measurement direction..... 3-5

Median filter 3-5

Mode..... 2-9

Model number..... 3-50

Moving average 3-4

Multi operations 3-39

N

Near On..... 3-24

No of decimal places 3-48

Normal..... 3-44

NPN..... 3-49

O

Off delay 3-25

On delay 3-25

One shot..... 3-25

On/off delay 3-25

Output 1 (DO1) setting 3-14

Output1 Mode..... 3-16

Output 2/Analog output (DO2/AO)..... 3-28

Output2 Mode..... 3-30

P

Peak-to-peak value..... 3-42

Peak value..... 3-41

PNP 3-49

PP..... 3-49

Process data..... 4-2

Process data format 4-19

Push-pull..... 3-49

R

Recording 2-5, 2-9

Reset customer settings 3-47

Reset factory settings 3-47

Restore 4-6

Rotate display..... 3-49

S

Sampling period..... 3-3

Save customer settings 3-47

Sensor operating hours 3-51

Serial number 3-50

Set clamp value 3-13

Span Teach, Auto 3-7

Span Teach, Manual..... 3-9

Span Teach Reset 3-47

Specifications 5-2

Spot size..... 5-7

U

UNLOCKED..... 2-10

Z

Zero point teach..... 3-40





Attention: Not to be Used for Personnel Protection.

Never use these products as sensing devices for personnel protection. Doing so could lead to serious injury or death. These sensors do not include the self-checking redundant circuitry necessary to allow their use in personnel safety applications. A sensor failure or malfunction can cause either an energized or de-energized sensor output condition. Please consult our distributors about safety products which meet OSHA, ANSI and IEC standards for personnel protection.

- Specifications are subject to change without prior notice.
- Specifications and technical information not mentioned here are written in Instruction Manual. Or visit our website for details.
- All the warnings and cautions to know prior to use are given in Instruction Manual.



OPTEX FA CO., LTD.

91 Chudoji-awata-cho, Shimogyo-ku, Kyoto 600-8815 JAPAN
TEL. +81-75-325-1314 FAX. +81-75-325-2936
<https://www.optex-fa.com>

The information in this user's manual is correct as of February 2023

CD2H_UM-E_001_2302