

**LASER MARKING SYSTEMS**



## **Operating Instructions**

**Foil STAR 300**

***Mark your territory...***

This product conforms to the requirements of the Directive 2006/42/EC on machinery.  
The CE symbol is located on the type plate.

Manufacturer: ACI Laser GmbH  
Steinbrüchenstraße 14  
D-99428 Grammetal OT Nohra  
Germany

Phone: +49 3643 4152-0  
Fax: +49 3643 4152-77  
info@ACI-Laser.de  
www.ACI-Laser.de

We are constantly working on further developments.

Therefore, please understand that we must reserve the right to change the scope of the delivery in respect of the form, equipment and technology at any time.

Reprinting, copying or translating this document in whole or in part is forbidden without the express written permission of ACI Laser GmbH!

All rights under the copyright laws are expressly reserved by ACI Laser GmbH.

The manufacturer shall only be responsible for the safety characteristics of this device within the scope of the legally applicable regulations if it is operated by the user in accordance with the operating instructions and repaired by ACI Laser GmbH itself or someone appointed by and acting under the instructions of ACI Laser GmbH.

Last update: 02/2019-03

© ACI Laser GmbH

Table of Contents

<b>1</b>	<b>Introduction</b> .....	<b>7</b>
<b>2</b>	<b>Important Information</b> .....	<b>7</b>
<b>2.1</b>	<b>Intended Use</b> .....	<b>8</b>
<b>2.2</b>	<b>Improper Use</b> .....	<b>9</b>
<b>2.3</b>	<b>Notices in the Document</b> .....	<b>9</b>
<b>2.4</b>	<b>Warranty</b> .....	<b>11</b>
<b>2.5</b>	<b>Technical Customer Service</b> .....	<b>12</b>
<b>3</b>	<b>Safety</b> .....	<b>13</b>
<b>3.1</b>	<b>Basic Safety Instructions</b> .....	<b>13</b>
	Laser safety .....	13
	Emissions .....	14
	General .....	14
	Start up .....	14
	Operation .....	15
	Maintenance/care .....	15
<b>3.2</b>	<b>Labels at the Device</b> .....	<b>16</b>
	Warning signs .....	16
	Type plate .....	17
<b>4</b>	<b>Description</b> .....	<b>18</b>
<b>4.1</b>	<b>Intended Purpose</b> .....	<b>18</b>
<b>4.2</b>	<b>Device View</b> .....	<b>19</b>
	Front side .....	19
	Rear side .....	20
<b>4.3</b>	<b>Sensors</b> .....	<b>21</b>
<b>4.4</b>	<b>Technical Specifications</b> .....	<b>22</b>

## Table of Contents

---

	Labelling field .....	22
	Material .....	22
	Transport speed .....	22
	Laser protection screen .....	23
	Interfaces .....	23
	Electrical data .....	23
	Operating conditions .....	23
	Weight .....	23
	Dimensions .....	24
	Options .....	24
<b>4.5</b>	<b>Scope of Delivery .....</b>	<b>25</b>
<b>5</b>	<b>Installation .....</b>	<b>26</b>
<b>5.1</b>	<b>Unpacking .....</b>	<b>26</b>
<b>5.2</b>	<b>Mechanical Installation .....</b>	<b>27</b>
	Setting up .....	27
	Connecting suction and extraction units .....	27
	Mounting the laser marking device .....	28
<b>5.3</b>	<b>Electrical Installation .....</b>	<b>29</b>
5.3.1	Interfaces .....	29
	Emergency stop connection .....	30
	Temperature sensor connection .....	30
5.3.2	Mains Connection .....	30
<b>5.4</b>	<b>Checking the Installation .....</b>	<b>31</b>
<b>6</b>	<b>Operation .....</b>	<b>32</b>
<b>6.1</b>	<b>Operating and Display Elements .....</b>	<b>32</b>
	Control panel .....	32
	Power switch .....	33
	Emergency stop button .....	33

<b>6.2</b>	<b>Handling .....</b>	<b>34</b>
6.2.1	Inserting the Material .....	34
	Setting the contact pressure .....	38
	Calibration of the edge sensor .....	40
6.2.2	Starting .....	40
<b>6.3</b>	<b>Errors and Troubleshooting .....</b>	<b>41</b>
	Error messages .....	41
	Troubleshooting .....	42
<b>7</b>	<b>Care and Maintenance .....</b>	<b>43</b>
<b>7.1</b>	<b>Cleaning .....</b>	<b>43</b>
7.1.1	Regular Cleaning Work .....	43
7.1.2	Cleaning Work at Greater Intervals .....	44
	Cleaning the pressing unit .....	44
	Cleaning the cutting unit .....	45
	Cleaning the teflon plate .....	46
	Cleaning the sensors .....	46
	Cleaning the deflection rollers .....	46
<b>7.2</b>	<b>Maintenance .....</b>	<b>46</b>
<b>8</b>	<b>Scrap Disposal .....</b>	<b>47</b>
<b>9</b>	<b>EC Conformity Declaration .....</b>	<b>48</b>
<b>10</b>	<b>Index .....</b>	<b>49</b>

## Table of Contents

---

## 1 Introduction

Dear customer,

Thank you for the confidence which you have shown in us by purchasing our quality product. We would like to wish you every success with the use of the devices.

Make yourself familiar with these operating instructions before starting use. It tells you how to use the new devices correctly and safely, and takes you step by step through the actions which have to be performed before using it for the first time.

## 2 Important Information

Our products are developed and manufactured under strict quality monitoring to give a long and fault-free service life.

This guarantees:

- highest quality and a long life,
- easy and safe operation,
- functional design,
- optimization for the intended purpose.

The **Foil STAR** is state-of-the-art. The Declaration of Conformity confirms that the manufacturer has complied with the relevant directives. The CE mark is located on the type plate.

Please read these operating instructions carefully from the beginning in order to avoid errors and risks.

Reference is made to residual hazards at the relevant places in the operating instructions. Please also take note of the warning notice stickers on the device.

### 2.1 Intended Use

- The device may only be used to label foils.
- The **Foil STAR** is intended exclusively for use with the following laser marking devices and the associated **Magic Mark** software:

**Economy Diode**

**Business Diode**

**DPL Smart Marker**

**DPL Magic Marker**

**DPL Genesis Marker**

**DPL Nexus Marker**

**DPL Fortis Marker**

**DPL Nobilis Marker**

**DPL Lexis Marker**

**Economy/Business Fibre**

**DFL Ventus Marker**

- Usage for the intended purpose includes observance of these operating instructions, the operating instructions of the laser marking device, the instructions in the software manual and the warning stickers on the device.



## 2.2 Improper Use

All other uses other than use for the intended purpose shall be deemed to be improper use!

The device must not be used by:

- persons who have not read or understood these operating instructions,
- persons who have not been instructed in the proper operation,
- persons who are under the influence of alcohol and or drugs, or
- persons whose alertness is impaired by medicines or other influences.

The device must not be used:

- if protective/safety devices are bridged, defective or if they cannot reliably fulfil their function,
- if there is a suspicion that direct or leakage radiation can emanate.

The supplier/manufacturer shall not be liable for personal injury or material damage resulting from improper use of the device itself or the safety devices.

## 2.3 Notices in the Document

Take note of the warning notices, take the specified actions and observe the prohibitions. A warning notice warns of a possible hazard and contains recommendations for preventing the hazard occurring. Key words indicate the type of hazard, symbols emphasise this visually.

Follow the stated measures for preventing hazards to the operator or tangible material assets.

The following classification of dangers is used in these safety instructions:

### **DANGER**

#### **RISK OF DEATH OR SERIOUS INJURIES!**

Indication of an imminent danger, which will result in death or serious injuries if the appropriate precautionary measures are not taken.

### **WARNING**

#### **DANGER OF INJURIES AND/OR RISK OF PROPERTY DAMAGE.**

Indication of an immediately impending hazard which can cause serious injuries or property damage if the appropriate precautionary measures are not taken.

### **CAUTION**

#### **RISK OF PROPERTY DAMAGE.**

Indication of a possible hazard which may cause damages of the equipment if the appropriate precautionary measures are not taken.

Additional information on working with the device and protection of the environment are emphasised as follows:

### **NOTICE**

**Useful additional information and tips!**

### **ENVIRONMENT**

**Protect the environment!**  
**Instructions for observing environmental protection regulations!**

## 2.4 Warranty

The manufacturer guarantees that the product does not have any manufacturing or material defects.

The warranty period shall be 12 months from the dispatch date in as far as no other contractual ruling has been made.

The scope of warranty is limited to the repair or replacement of the product supplied by the manufacturer.

The manufacturer is responsible for returning repairs under warranty to the customer, the customer is responsible for returning the device to the manufacturer.

The manufacturer does not accept any liability,

- if the product has been damaged by incorrect handling or operation, or as a result of improper use,
- if seals on the device have been broken,
- for damage caused by use under unauthorized environmental conditions,
- for consequential damage.

### 2.5 Technical Customer Service

ACI Laser GmbH  
Steinbrüchenstraße 14  
D-99428 Grammetal OT Nohra  
Germany

Phone: +49 3643 4152-0  
Fax: +49 3643 4152-77  
service@ACI-Laser.de  
www.ACI-Laser.de

#### NOTICE

The device may only be maintained and repaired by the manufacturer. Any manipulations on the device or breaking the warranty seal will void any claims under warranty.

## 3 Safety

### 3.1 Basic Safety Instructions



The following safety instructions have fundamental importance for the use of the device, and for its care and maintenance. They must always be followed and are only stated centrally here.

#### Laser safety

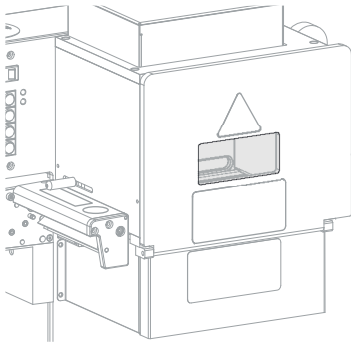

If used properly, the **Foil STAR** with mounted laser marking device can be operated in laser protection class 1.

The laser protection screen in the viewing window is matched to the characteristics of the laser marking device. The specification corresponds at least to the required protection level and can be taken from the adhesive label on the window.

- Only use the **Foil STAR** and laser marking device in the combination supplied by the manufacturer!
- If the protection screen is damaged, the device must not be operated.

## Safety

---

### Emissions

- Chemical and physical reactions during the laser marking can cause
  - gases,
  - vapours,
  - aerosols,
  - dusts,
  - mists or
  - other reaction products

to be given off from the material surface.

These may be toxic, depending upon the material being processed. The operating company must therefore provide effective extraction. Information about this can be found, for example, in the VDI Guideline 2262 1 to 3 "Air Quality in the Work Place".

### General

- Read the Operating Instructions, and keep them at hand at all times.
- Follow the Operating Instructions for the laser marking device.
- Follow the Operating Instructions for the air conditioner and the instructions for any other devices made by other manufacturers (for example extraction units).
- Do not mark any easily flammable or combustible materials.

### Start up

- Each time before starting up, ensure that all safety devices are mounted and working perfectly.
  - Covers
  - Door mechanism
  - Emergency stop button
- Never use the device system immediately after large temperature changes. Condensation water may damage the device.
- The **Foil STAR** may only be coupled to devices with safety extra-low voltage (SELV).

- When establishing the connections, ensure that all devices to be connected (computer, etc.) are switched off.

The devices must also be switched off when connections are disconnected.

### Operation

- The **Foil STAR** may only be operated by trained personnel.  
It is advisable to log both the initial training as well as the regular refresher courses.
- The device may only be operated when connected to an alternating voltage supply corresponding to the specifications on the type plate.
- The effectiveness of the protective conductor must be regularly checked and confirmed by an authorized skilled worker.
- If a defect occurs in the device, it must be disconnected from the power supply system and secured against being switched on again.
- During the operation of the device, do not touch any area of the moving blades of the cutter!
- Do not cut any materials, whose width and thickness exceed the specifications!

### Maintenance/care

- Only perform maintenance and repair work on the **Foil STAR** as is described in these instructions. All other work may only be carried out by the manufacturer.
- Disconnect the device from the power supply before starting cleaning and care tasks.
- Do not touch the electrical/electronic components.
- The blades of the cutter are sharp; there is a risk of injury - particularly when doing maintenance work! Use protective gloves.

## 3.2 Labels at the Device

### Warning signs

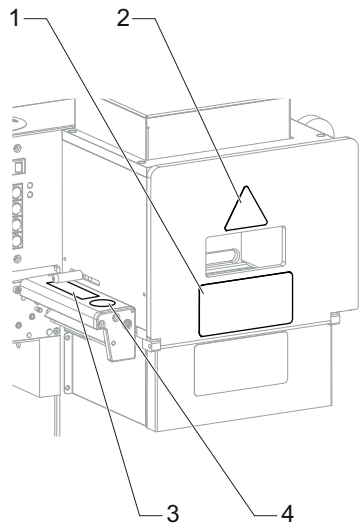

The warning signs on the device indicate possible residual hazards.

- On the safety door (1, 2): Laser radiation warning!



- On the cutting unit:
  - Caution rotating knife (3)
  - Disconnect the mains plug (4)

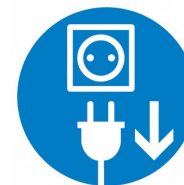



**Type plate**

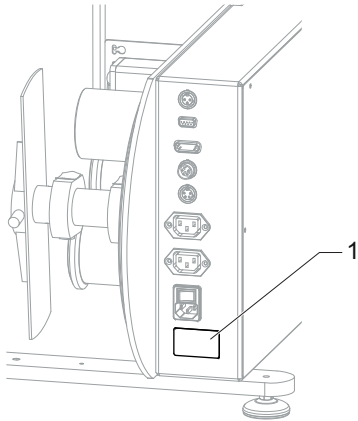

The type plate (1) on the rear of the device contains information about:

- Serial number,
- Manufacturer,
- Date of manufacture,
- Operating voltage/frequency range,
- Power consumption,
- Fuse,
- Laser protection screen on the device.

## Description

---

### 4 Description

#### 4.1 Intended Purpose

The **Foil STAR** has been developed to label special foils using laser systems.

The foil transport and labelling process are controlled by the laser system software.

Both endless materials and labels from a roller up to a roller diameter of 300 mm can be used. The **Foil STAR** is equipped with two sensors for identifying materials and labels as well as sensors for measuring material jam and temperature.

The chamber, in which the laser marking takes place, is closed by a door with a laser safety glass. If the door is opened during the labelling, the process is interrupted by the deactivation of the laser.

The material is sucked to the work surface by the connected extraction unit.

After the labelling, the material can be cut via an integrated knife.

An emergency stop switch enables the immediate interruption of the process.

The additional equipment with an extraction unit is necessary to remove the ablated particles.

All the connections required for the operation and functionality of the laser are prepared.

## 4.2 Device View

Front side

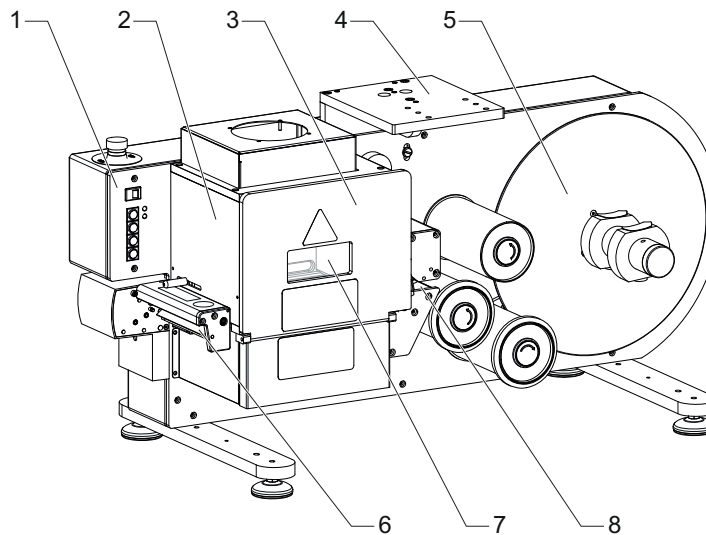

- |                                     |                             |
|-------------------------------------|-----------------------------|
| (1) Control panel                   | (5) Unwinder                |
| (2) Labelling chamber               | (6) Cutting unit            |
| (3) Safety door                     | (7) Laser protection screen |
| (4) Mounting plate for laser device | (8) Pressing unit           |

## Description

---

### Rear side

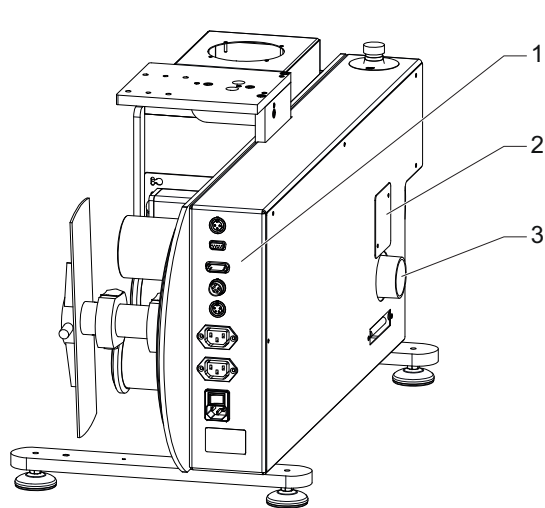

- (1) Electrical interfaces
- (2) Connection for extraction unit (with cover)
- (3) Connection for sucking unit

### 4.3 Sensors

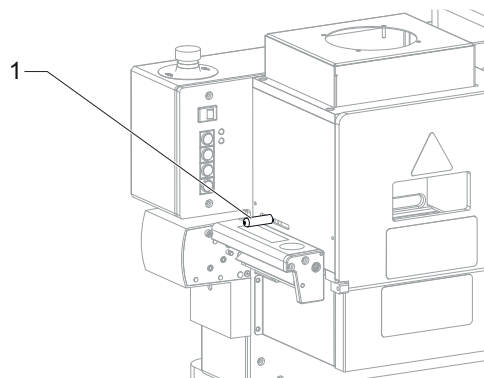

- (1) Edge sensor
- (2) Temperature sensor
- (3) Temperature sensor
- (4) Jam sensor reflector
- (5) Jam sensor
- (6) End-of-material sensor

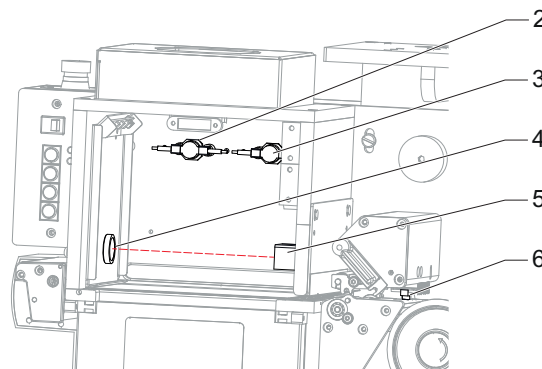

## Description

---

With the help of the edge sensor (1), the initial positions of labels are detected.

The temperature sensor (2) is a potential-free opener for the customer's safety circuits. The contact opens at temperatures above 70°C in the labelling chamber and can be integrated into fire alarm systems.

The temperature sensor (3) is part of the internal safety circuit and switches off the laser. If the jam detector malfunctions, the label material may accumulate in the labelling chamber and catch fire when additional labels are printed in automatic operation.

The jam sensor (5) is evaluated via the laser I/O interface.

The end-of-material sensor (6) reports the end of a material roll.

## 4.4 Technical Specifications

<b>Labelling field</b>	Width:	max. 120 mm
	Depth:	max. 160 mm (dependent on the objective of the laser marking device)
<b>Material</b>	Continuous foil or labels on rolls	
	Width:	max. 120 mm
	Thickness:	max. 0.3 mm
	Weight:	max. 300 g/mm <sup>2</sup>
	External roll diameter:	max. 300 mm
	Core roll diameter:	76 mm
	Foil unwinding:	internal or external
<b>Transport speed</b>	Feed rate:	100 mm/s
	Retraction rate:	100 mm/s

---

<b>Laser protection screen</b>	Specification:	depends on the type of laser device used
	Nd:YAG laser:	1064 nm      D AB6 IR AB7 (DIN EN 12254)
	Nd:YVO4 laser:	532 nm      180 - 535 OD 5+ (DIN EN 12254) 355 nm
	Yb:fibre laser:	>700 - 1200 nm      D LB7 IR LB8 (EN 207)
	The listed laser protection screen specifications are the minimum requirements for the protective windows. Depending on the application, laser protection screens with higher levels of protection may be installed. The specifications of the laser protection screen can be found on the adhesive label on the window.	
<b>Interfaces</b>	PC:	Serial RS 232 C 9600 baud/8 bit
	Laser:	Control interface
<b>Electrical data</b>	Connection loads:	100 - 240 V/50 - 60 Hz, PFC
	Power consumption:	max. 100 W
<b>Operating conditions</b>	Operating temperature:	10 °C - 40 °C
	Humidity:	30% - 85%, not condensing
<b>Weight</b>	26 kg	

---

## Description

---

### Dimensions

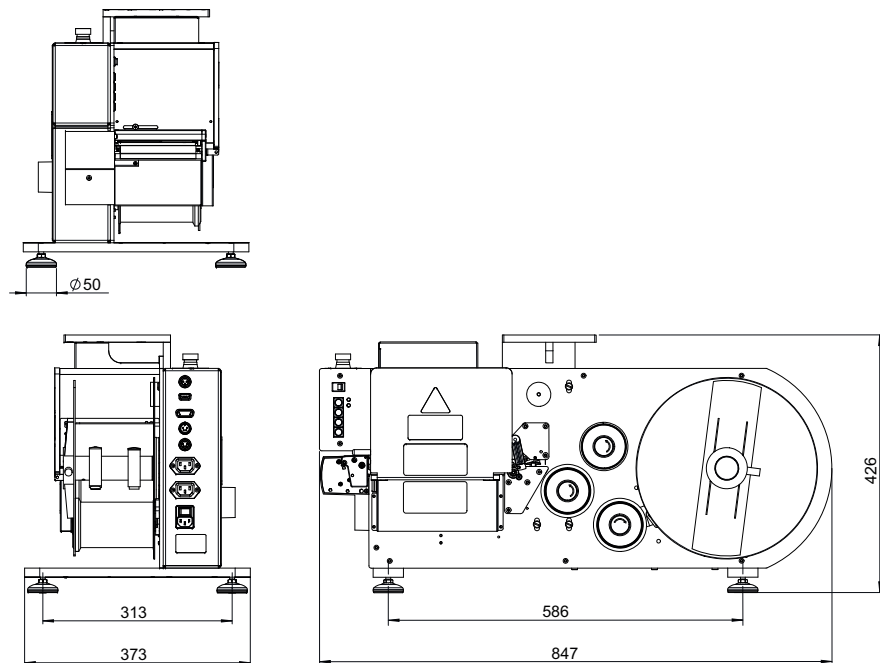

### Options

- External rewinder, roll diameter 300 mm
- Extraction and filter system 220 V
- Connection cable serial/9-pole serial, 1.8 m



---

## 4.5 Scope of Delivery

- **Foil STAR**,
- laser interface cable,
- power cable,
- fixing screws for laser device,
- 2 x extraction hose,
- 2 x hose adapter,
- blind plug,
- deflection roller,
- throttle,
- emergency stop switch,
- cold-device extension,
- 2 x Sub-D 9-pole cables,
- information and warning signs,
- operating instructions.

### NOTICE

Check that the delivery is complete and undamaged. Please contact our service department if you have any queries.

### 5 Installation

 <b>WARNING</b>	
	<p><b>RISK OF PERSONAL INJURIES AND MATERIAL DAMAGE FROM LASER RADIATION!</b></p> <p><b>All safety-related devices must be installed and their effectiveness proven before the system is started up. The acceptance must be performed by the laser safety officer and recorded in writing.</b></p> <p><b>For safety reasons, the laser must not be activated until all the above-mentioned conditions have been fulfilled.</b></p>

#### 5.1 Unpacking

The device is delivered packed in a box.

1. Open the box at the top. Note the TOP marking!
2. Remove the device from the box and place on a level surface.
3. Remove the accessories and place next to the device.
4. Check the scope of delivery

<b>NOTICE</b>
<p><b>Store the packaging material in a safe place in case the device has to be returned to the manufacturer under warranty for maintenance and repair work.</b></p>

To do this, stow the device in the reverse sequence back in the original packaging and close securely.

## 5.2 Mechanical Installation

### Setting up

Set up the device horizontally on a level surface and - as needed - level it using the height-adjustable feet.

### Connecting suction and extraction units

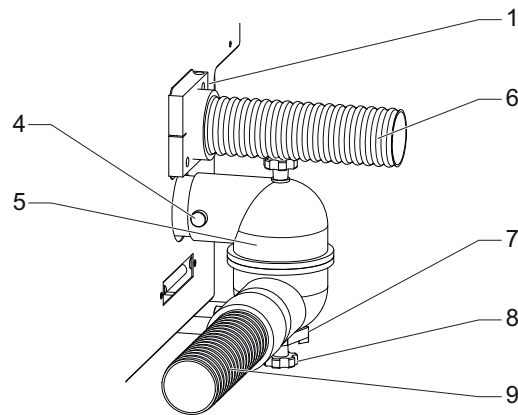
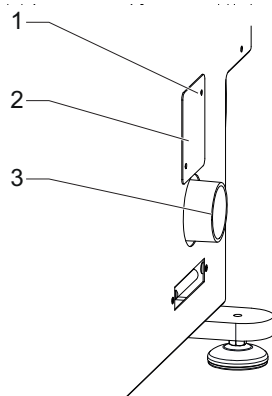

### Connecting

1. Plug material-suction hose (9) with throttle (5) into adapter (3) and secure with screw (4).
2. Loosen screws (1) and remove cover (2).
3. Plug hose (6) for extracting the ablated particles into the upper vacuum hole and secure with screws (1).

### Setting the suction pressure

In order to ensure a correct material transport, it is necessary to set the throttle (5) to regulate the suction pressure according to the material used.

- In the event that jamming occurs during the transport of the material due to too strong suction on the material, it is necessary to further close the throttle.
- If the material is not guided evenly along the floor of the labelling chamber during transport, it is necessary to further open the throttle.

To do this, proceed as follows:

1. Loosen knurled screw (8).
2. Change lever (7) setting as required.
  - Clockwise turning:  
Throttle is opened - suction pressure is increased
  - Turning anticlockwise  
Throttle is closed - suction pressure is decreased
3. Tighten knurled screw (8).

### Mounting the laser marking device

Mount the laser marking device onto the mounting plate of the **Foil STAR** in accordance with the instructions provided in the operating manual.

## 5.3 Electrical Installation

### 5.3.1 Interfaces

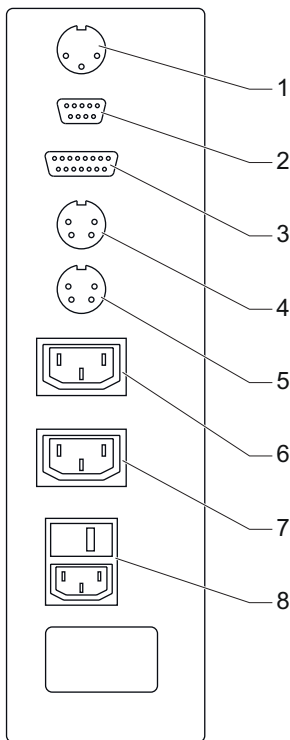

 <b>WARNING</b>	
	<b>DANGER OF INJURIES AND/OR RISK OF PROPERTY DAMAGE.</b> The device interfaces may only be connected to the plant by an electrician in cooperation with a laser safety officer!

The interfaces are located on the rear panel.

- (1) Temperature sensor connection
- (2) PC - RS 232 interface
- (3) Port for laser control interface
- (4) Interlock connection
- (5) Emergency stop connection
- (6) Mains connection for laser (optional)
- (7) Mains connection for external rewinder
- (8) Power switch/Power input

## Installation

---

### Emergency stop connection

Integrate the emergency stop button provided via the emergency stop connection for the entire system.

### Temperature sensor connection

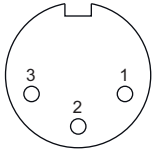

Temperature sensors installed in the interior monitor the temperature in the processing area.

The **Foil STAR** can be connected to an external safety device via the temperature sensor connection. A potential-free opener is connected between pin 1 and 2.

### 5.3.2 Mains Connection

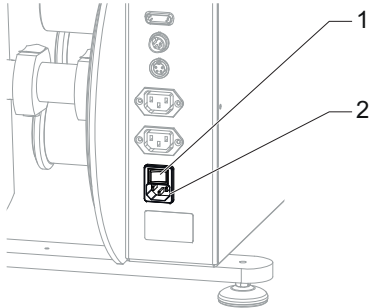

1. Ensure that the power switch (1) of the device is switched off.
2. Connect the power cable provided to the power entry module (2) of the device.
3. Connect the power cable to a shockproof socket.

## 5.4 Checking the Installation



**RISK OF PROPERTY DAMAGE.**  
**Perform the following tests to avoid material damage.**

Please check the following points again before you start your laser system:

- Have the mechanical and electrical installations been performed correctly and completely?
- Does the fuse for the device correspond to the available operating voltage?
- **Have you removed the protective cover from the focusing objective?**
- Is the focusing objective clean and dust-free?
- Do the environmental conditions meet the requirements (temperature, air humidity)?
- Are all the vents open?
- Is there an adequate fresh air supply to the laser device?
- Are you familiar with the essential laser protection regulations? Have all the laser safety measures been taken?
- Has the laser safety officer accepted the installation?

### 6 Operation

#### 6.1 Operating and Display Elements

##### Control panel

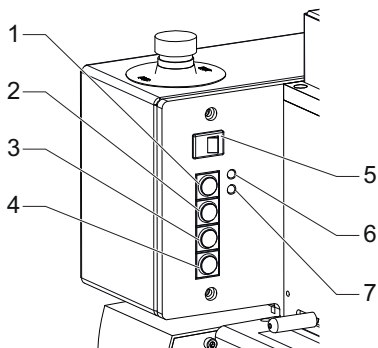

- (1) Endless material/Labels selector switch
- (2) Retraction button
  - Retraction as long as the button is pressed
- (3) Material feed button
  - Endless material: Feed as long as the button is pressed
  - Label material: Feed up to the marking position of the next label
- (4) Cutting button
  - Endless material: Activation of a cutting process
  - Label material: Feed and cutting of the current label, Retraction to the marking position of the next label
- (5) Automatic operation/Manual operation selection switch
- (6) Endless material LED
- (7) Label material LED



**Power switch**

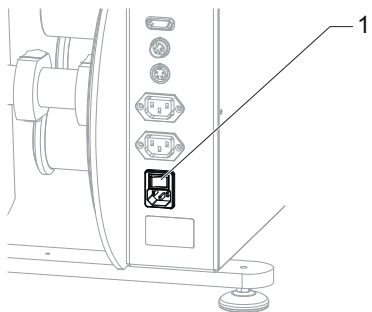

The power switch (1) is used to switch on/off the power supply for the **Foil STAR**, an external rewinder as well as the laser marking device (when supplied via the mains connection of the **Foil STAR**).

**Emergency stop button**

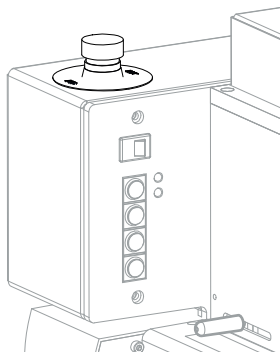

The internal emergency stop button is located at the top of the device, while a second one with the same function is installed at the emergency stop connection.

Press the emergency stop button in situations, which represent a danger to the operating personnel or the device system, in order to shutdown the system immediately!

Activating the emergency stop button:

- interrupts the power supply to the **Foil STAR**,
- interrupts the power supply to an external rewinder,
- interrupts the laser marking device interlock circuit.

**⚠ WARNING**

**DANGER OF INJURIES AND/OR RISK OF PROPERTY DAMAGE.**  
 Ensure that the cause of the risk has been rectified before unlocking the emergency stop button!

### NOTICE

By unlocking the emergency stop button, the power supply is switched back on. The same procedures are followed as when switching on the device using the power switch.

## 6.2 Handling

### 6.2.1 Inserting the Material

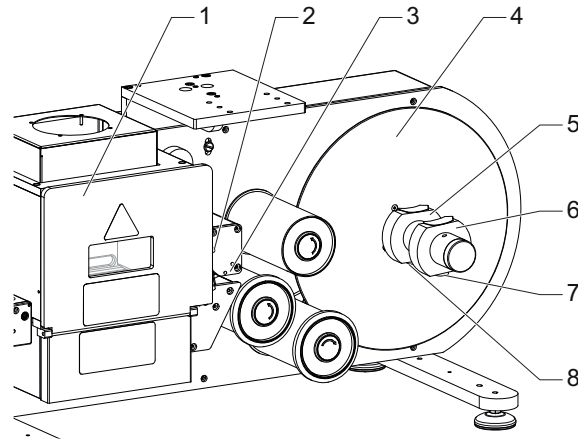

1. Slide the adapter (5) until it reaches the stop at the winding disc (4). Tighten knurled screw (8).
2. Position the adapter (6) so that the distance between the outer edge of the adapter and the winding disc (4) is just less than the width of the label roller. Tighten knurled screw (8).
3. Set the foil roll onto the adapter (5, 6) and slide to the winding disc (4).

### NOTICE

The side of the material to be labelled must be facing upwards.

4. Swivel the lever (2) upwards, thus opening the pressing unit (3).
5. Lower the door (1) and open the labelling chamber.

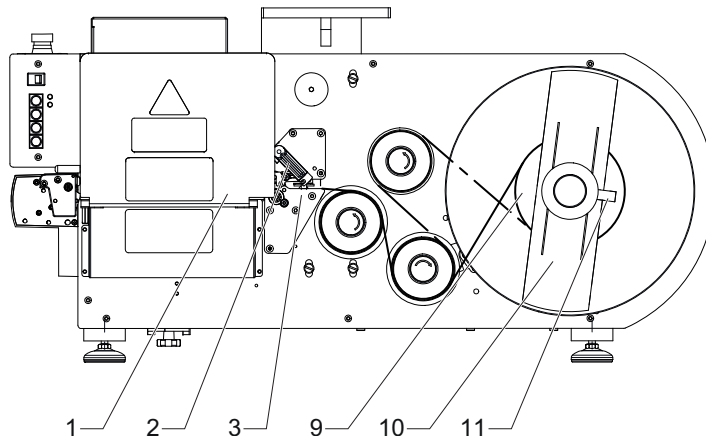

- Uncoil the foil strip from the roll (9) and guide through the pressing unit (3) into the labelling chamber as shown in the illustration.  
It is necessary to distinguish between inner and outer winding material - the solid line applies to outer winding material and the broken line to inner winding material.

### NOTICE

The foil strip must pass through the end-of-material sensor (13) in the pressing unit (3).

### NOTICE

The foil strip must lie along the guide rail (12) in the labelling chamber.

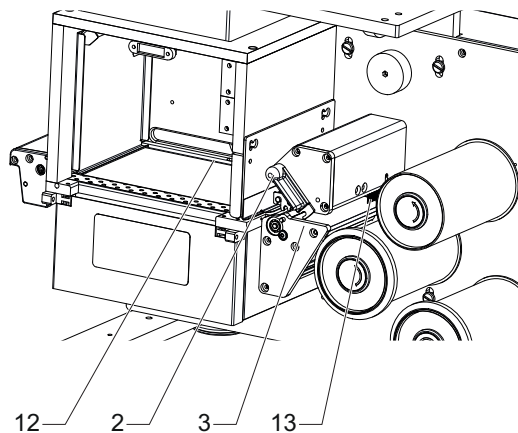

7. Swivel the lever (2) downwards, thus closing the pressing unit and clamping the material.
8. Slide the flange (10) on the unwind mandrel against the roll (9). Tighten the knurled screw (11).
9. Raise the door (1) and close the labelling chamber.

### NOTICE

After every change from endless to label material - and vice versa:  
Press and hold down the **endless material/labels** selection switch, and operate the **automatic operation/manual operation** selection switch.  
This results in the switching of the material mode and the corresponding LED lights up.

## Operation

### Setting the contact pressure

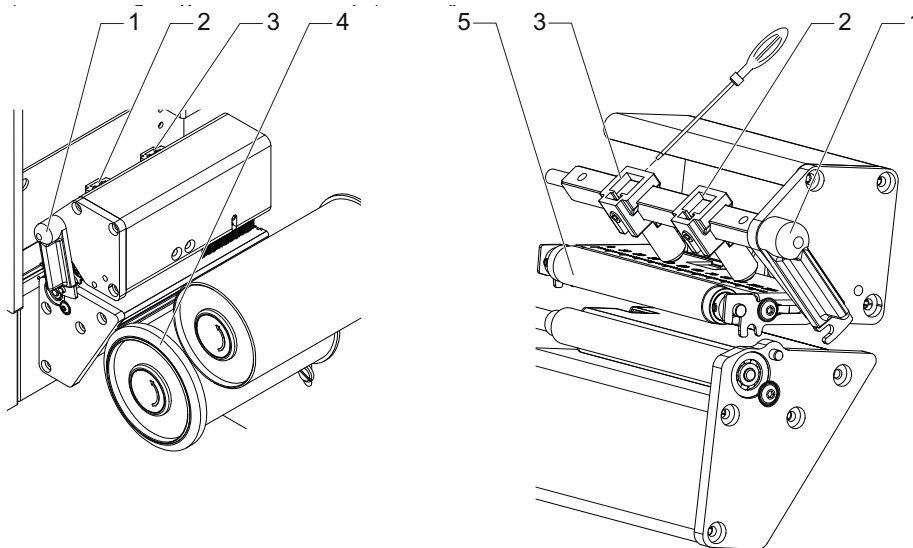

Adjust the position of the pressure bolt on the pressure roller (5) to the foil width:

1. Swivel the lever (1) upwards, thus opening the pressing unit, to achieve the locking of the pressure bolts.
2. Loosen pressure bolt (3) (allen key 2.5 mm), slide to the mounting wall and retighten.
3. Loosen pressure bolt (2) (allen key 2.5 mm) and slide so that the distance between the two pressure bolts corresponds to the width of the foil strip.  
Retighten pressure bolt (2).
4. Loosen the material guide (4), slide against the foil strip and retighten.
5. Swivel the lever (2) downwards, thus closing the pressing unit.

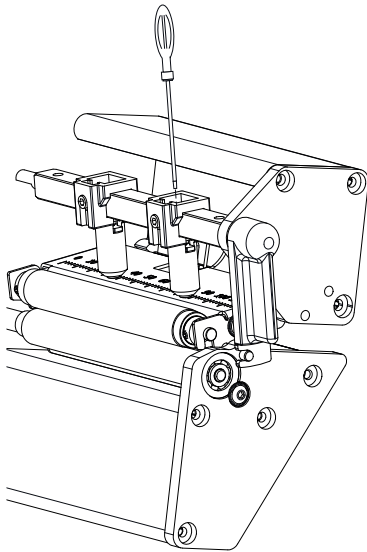

If the foil is skewed, then the pressure of the bolts on the pressure roller has to be additionally adjusted.

For this purpose, screw the relevant pressure bolt in or out (allen key 2.5 mm) with the pressing unit closed.

## Operation

### Calibration of the edge sensor

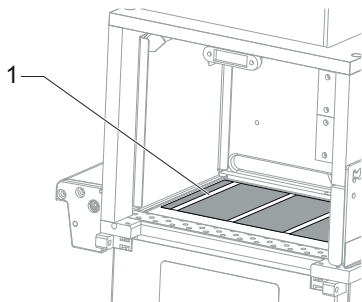

In manual operation and label mode, it is possible to calibrate the edge sensor in order to optimise the material identification.

1. Switch the **Foil STAR** to manual operation and label mode.
2. Insert the material so that the label gap (1) is approx. 20 mm in front of the edge sensor.
3. Press the **Retraction** and **Feed** buttons at the same time and switch on the power supply to the device.

The material is moved forwards by approx. 50 mm. The values for the label gap and material are read and permanently stored in the device.

#### NOTICE

Depending on the material properties, it may be necessary in rare cases to teach the edge sensor. Please contact the service here.

### 6.2.2 Starting

1. Install the laser.
2. Establish all the connections required.
3. Connect the suction device.

#### NOTICE

It is absolutely necessary that the suction device for drawing in the material to be labelled in the labelling chamber is connected - otherwise a proper labelling process cannot be ensured!

4. Connect the extraction system.



5. Insert the material.
6. Switch on the laser.
7. Switch on the power supply to the device.
8. Open and re-close the safety door in order to activate the safety circuit.

<b>NOTICE</b>
Check that the LED corresponding to the material to be labelled is lit up.

9. Start the laser software.

<b>NOTICE</b>
The laser process is interrupted if the door to the labelling chamber is opened during the process.

### 6.3 Errors and Troubleshooting

#### Error messages

Error	Description	Display
No label	There is no label in the marking position.	Endless material LED or Label material LED flashing
No material	There is no material in the end-of-material sensor.	Endless material LED or Label material LED flashing
Pressing unit open	The pressing unit has not been closed.	Endless material LED or Label material LED flashing

## Operation

---

<b>Error</b>	<b>Description</b>	<b>Display</b>
Cutter error	The cutting has not been properly performed.	Endless material LED or Label material LED flashing
Material jam	The foil material has jammed in the labelling chamber.	The interlock circuit is interrupted. The laser is no longer labelling.
Temperature too high	The temperature in the labelling chamber is too high.	The temperature sensor has produced an interlock error. The laser has been switched off.

## Troubleshooting

1. Rectify cause of error.
2. Trigger RESET command using the software.
3. Continue labelling process.

## 7 Care and Maintenance

### 7.1 Cleaning

 **WARNING**

**DANGER OF INJURIES AND/OR RISK OF PROPERTY DAMAGE.**  
Ensure that the power plug has been pulled out before starting the maintenance and cleaning work!

 **WARNING**

**DANGER OF INJURIES AND/OR RISK OF PROPERTY DAMAGE.**  
The blades of the cutter are sharp.  
Wear protective gloves.

The individual components of the device must be cleaned at regular intervals. These intervals must be determined by the user depending on the type and scope of use.

#### 7.1.1 Regular Cleaning Work

- Clean the laser objective (refer to Laser Marking Device Manual),
- Remove dust deposits from the labelling chamber,
- Clean jam sensor.

### 7.1.2 Cleaning Work at Greater Intervals

#### Cleaning the pressing unit

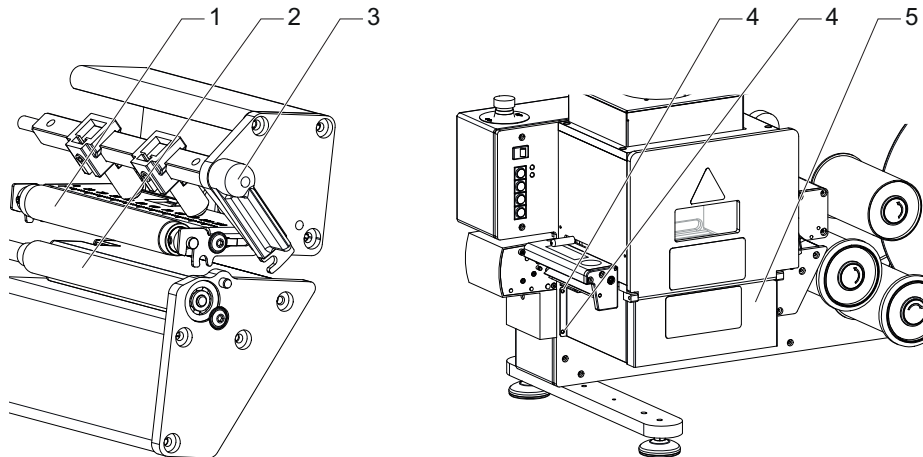

1. To clean the pressure roller (1), open the pressing unit and remove the material.
2. To clean the transport roller, remove the suction box (5) located beneath the teflon plate. To do this, loosen the two screws (4) on the left side and the two on the right side. The transport roller is now accessible from underneath.
3. Remove deposits from the rollers with spirit and a soft cloth.
4. Reattach suction box.

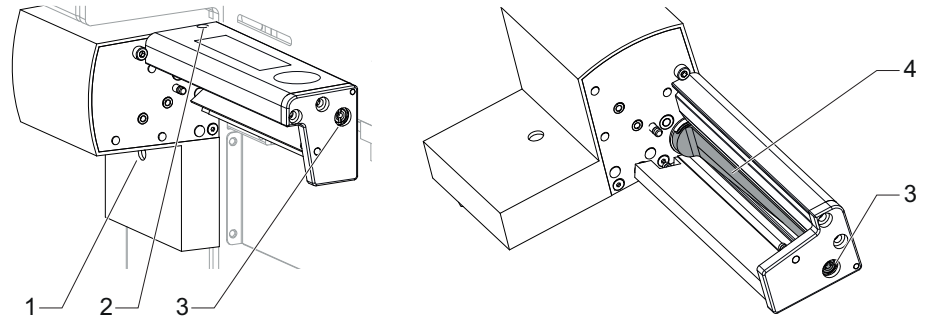
**Cleaning the cutting unit**

1. Loosen screw (1) (allen key 2.5 mm) and dismantle cutting unit.
2. Remove deposits from the blades with spirit and a soft cloth. To do this, lightly press down the fixed cutting blade and turn the axle (3) for the circular blade (4) using a flat-bladed screwdriver (cutting width 7 mm).  
To be able to turn the circular blade without limitation, it is necessary to loosen the locking screw (2).
3. Retighten the locking screw (2) and secure cutting unit with screw (1).

## Care and Maintenance

---

### Cleaning the teflon plate

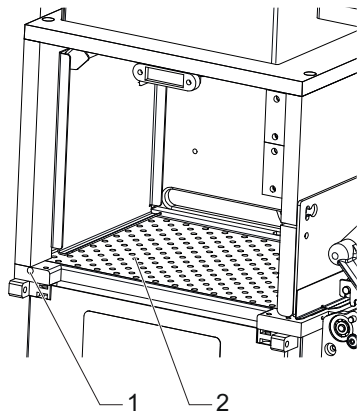

1. When the cutting unit has been removed, loosen the teflon plate (2) at the grub screw (1) (allen key 2 mm) and slide out in the direction of the cutting unit.
2. Clean the teflon plate, slide back into the device and fix in place with the grub screw

### Cleaning the sensors

1. To clean the end-of-material sensor, remove the foil material. To clean the edge sensor, remove the cutting unit.
2. Clean the sensors with compressed air.

### Cleaning the deflection rollers

Clean the deflection rollers to remove any adhesive residues.

## 7.2 Maintenance

In the event of any necessity for maintenance work or repairs, say, when the cutting unit has to be replaced, please contact the manufacturer.

8 Scrap Disposal

**ENVIRONMENT**

**Protect the environment!**

**For a fee, the customer will accept return of the laser device and dispose of it properly in a manner that is environmentally compatible.**

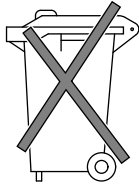

**Environmentally sensible disposal of electrical and electronic equipment!**

Electrical and electronic equipment contains valuable materials that should be supplied to recycling or recovery.

Please dispose of electrical and electronic equipment at qualified collecting points separate from municipal waste.

## 9 EC Conformity Declaration

We herewith declare that the device described below, by virtue of its design and construction and moreover in the type brought onto the market by us, conforms to the relevant safety and health requirements of the applicable EU Directives. We further declare that the device as defined hereinbelow conforms to class laser safety class 1.

In the event of any alteration to the device or the intended purpose which has not been approved by us, this statement shall thereby be made invalid.

Device:

Labelling device with marking laser

Type:

Labelling device:

Marking laser:



Applied EC directives and standards:

Directive 2014/30/EC through

Electromagnetic compatibility

Directive 2011/65/EU on Hazardous

Substances (RoHS)

Directive 2006/42/EC through Machines

EN 55022:2010

EN 55024:2010 + A1:2015

EN 61000-3-2:2014

EN 61000-3-3:2013

EN 50581:2012

EN ISO 12100:2010

EN ISO 13857:2008

EN 349:1993+A1:2008

EN 60204-1:2006+A1:2009

EN 60825-4:2006+A1:2008+A2:2011

Representative for compiling technical documents: Mirko Wunderlich, Steinbrüchenstraße 14, 99248 Grammetal OT Nohra

Signed on behalf of the manufacturer by:

Nohra, 2019-02-01



ACI Laser GmbH

Steinbrüchenstraße 14, 99428 Grammetal OT Nohra

Mirko Wunderlich, Geschäftsführer



---

**10 Index****A**

Automatic operation/Manual operation selection switch ..... 32

**C**

Care ..... 15

CE symbol ..... 7

Cleaning ..... 43

Cleaning the cutting unit ..... 45

Cleaning the deflection rollers ..... 46

Cleaning the pressing unit ..... 44

Cleaning the sensors ..... 46

Cleaning the teflon plate ..... 46

Connecting extraction unit ..... 27

Connecting suction unit ..... 27

Control panel ..... 19, 32

Customer service ..... 12

Cutting button ..... 32

Cutting unit ..... 19

**D**

Date of manufacture ..... 17

Defect ..... 15

Dimensions ..... 24

**E**

EC conformity declaration ..... 48

Edge sensor ..... 21

    Calibrating ..... 40

    Teaching ..... 40

Electrical data ..... 23

Electrical installation .....	29
Emergency stop button .....	33
Unlocking .....	33
Emergency stop connection .....	29
Emissions .....	14
Endless material LED .....	32
Endless material/Labels selector switch .....	32
End-of-material sensor .....	21
Extraction .....	14
<b>F</b>	
Frequency range .....	17
Fuse .....	17
Fuse protection .....	31
<b>I</b>	
Improper use .....	9
Inserting the material .....	34
Installation .....	26
Instructions .....	15
Intended use .....	8
Interfaces .....	23, 29
Interlock connection .....	29
<b>J</b>	
Jam sensor .....	21
<b>L</b>	
Label material LED .....	32
Labelling chamber .....	19
Labelling field .....	22
Laser protection class .....	13

---

Laser protection screen .....	13, 17, 19
Laser safety .....	13
Liability .....	9
<b>M</b>	
Mains connection .....	30
Maintenance .....	15
Manufacturer .....	17
Manufacturer's address .....	12
Material .....	18, 22
Inner winding .....	36
Outer winding .....	36
Material feed button .....	32
Mechanical installation .....	27
Mounting plate .....	19
<b>O</b>	
Operating conditions .....	23
Operating voltage .....	17, 31
Operation .....	15
<b>P</b>	
PC - RS 232 interface .....	29
Port for laser control interface .....	29
Power consumption .....	17
Power entry module .....	30
Power input .....	29
Power switch .....	29
Pressing unit .....	19, 35
<b>R</b>	
Repair work .....	15

---

Residual hazards .....	7, 16
Retraction button .....	32
<b>S</b>	
Safety door .....	19
Safety instructions .....	13
Scope of delivery .....	25
Scrap disposal .....	47
Serial number .....	17
Setting the contact pressure .....	38
Setting the suction pressure .....	28
Start up .....	14
<b>T</b>	
Technical specifications .....	22
Temperature sensor .....	21
Connection .....	29
Transport speed .....	22
Type plate .....	17
<b>U</b>	
Unwinder .....	19
<b>V</b>	
Vents .....	31
<b>W</b>	
Warning signs .....	16
Warranty .....	11
Weight .....	23





## Operating Instructions for **Foil STAR 300**

Article number: 10001782

Version: EN 02/2019-03

ACI Laser GmbH  
Steinbrüchenstraße 14  
D-99428 Grammetal OT Nohra

Phone: +49 3643 4152-0

Fax: +49 3643 4152-77

[info@ACI-Laser.de](mailto:info@ACI-Laser.de)

[www.ACI-Laser.de](http://www.ACI-Laser.de)

*Mark your territory...*