

Color Area and Shape Vision Sensor

# CVS2-RA Series

CVS2-10-RA CVS2-20-RA CVS2-21-RA CVS2-40-RA

Instruction Manual

- Thank you for purchasing this product. Before using this product, confirm that the product you have received is the product that you requested.
- Read this instruction manual thoroughly before use, and keep it in a safe location.

0633145

**Warning** Indicates that incorrect use may lead to a hazardous situation resulting in injury or death. Also indicates a risk of significant property damage.

**Warning**

- This product is not explosion-proof and should not be used around flammable or explosive gases or liquids.
- Doing so may cause injury, fire, or electric shock. This product cannot be used as protective equipment for the purpose of protecting the human body.

**Caution**

- It is dangerous to wire or attach/remove the connector while the power is on. Make sure to turn off the power before operation.
- Installing in the following locations may result in malfunction:
  - Dusty or steamy locations.
  - Locations with direct exposure to water or oil splashes.
  - Locations where corrosive gas is generated.
  - Locations where heavy vibrations or impacts may occur.
- The product is not designed for outdoor use.
- Do not wire with high voltage cables or power lines. Doing so may cause malfunction or damage by induction.
- Detection characteristics may vary depending on the state of the target object and variations among individual products.
- Do not use the product in water.
- Do not disassemble, repair, or modify this product. Doing so may cause injury, fire, or electric shock.
- Operate within the rated ranges.

### Included accessories

Please confirm that the following accessories are included in the box.

- CVS2-□□□-RA
- This instruction manual
- Mounting screws (M4 x 50), 2 pcs. (including washers and nuts)

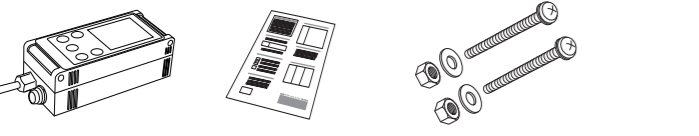

### I/O circuit diagram

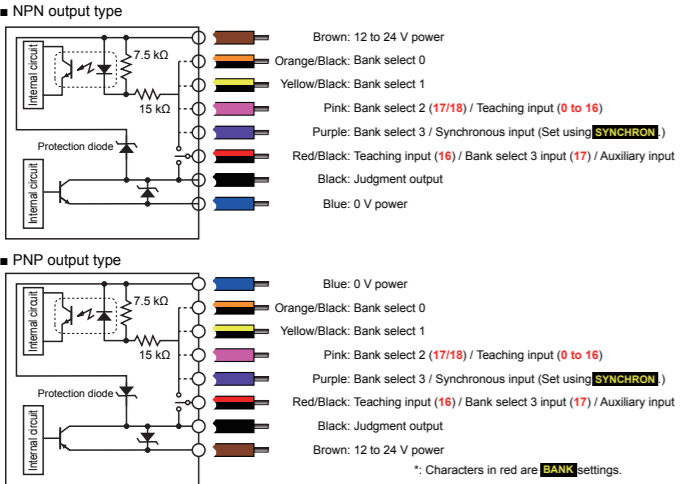

### Names of parts

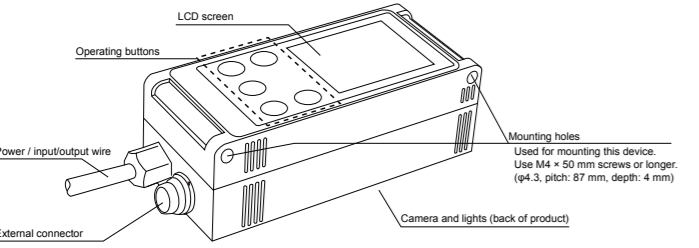

### Specifications

Model	CVS2-N10-RA CVS2-P10-RA	CVS2-N20-RA CVS2-P20-RA	CVS2-N21-RA CVS2-P21-RA	CVS2-N40-RA CVS2-P40-RA
Detection angle	10°	20°	31°	40°
Working distance	210 to 270 mm	90 to 150 mm	31 to 39 mm	50 to 100mm
Field of view (±10%)	40 × 50 mm to 55 × 65 mm	40 × 50 mm to 65 × 75 mm	17 × 20 mm	46 × 55 to 82 × 98 mm
Light source	White LED, 12 pcs. built in			
Power supply voltage	12 to 24 VDC			
Current consumption	Max. 140 mA / 24 VDC			
Inspection window size	8×16 to 208×236			
Illumination life	Approx. 50,000 hours (normal temperature and humidity, brightness decreased from initial level by 1%)			
Response time	18.8 ms (initial setting), 15 ms (min.), 36.4 ms (max.)			
Output signal	NPN/PNP open collector output × 2 Max. 100 mA, 1.0 V residual voltage or less			
Input	Bank selection / Synchronized / External teaching input × 4			
Protection category	IP67			
Operating temperature/humidity	0 to +40°C/35 to 85%RH (no condensation or freezing)			
Storage temperature/humidity	-20 to +70°C/35 to 95%RH (no condensation or freezing)			
Vibration resistance	10 to 55 Hz; double amplitude 1.5 mm; 2 hours in each of the X, Y, and Z directions			
Shock resistance	Approx. 50 G (500 m/s <sup>2</sup> ), 3 times in each X, Y, and Z direction			
Applicable regulations	EMC (2014/30/EU); RoHS (2011/65/EU, MIIT Order No.32)			
Applicable standards	EN 61000-6-2, EN 61000-6-4			
Material	Housing: ABS; Emitter and receiver: Acryl		Emitter and receiver: PC	
Weight	Approximately 200 g			

### Dimensions

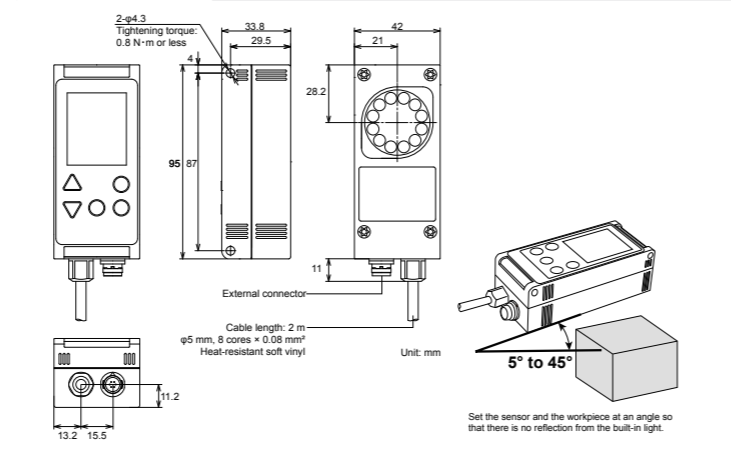

### Options

Category	Model	Description
Remote monitor	CVS-M1-R	This is the monitor unit for use with the CVS series. This allows results to be checked away from the workpiece and can be set up similar to the main unit.
Extension cable (3 m)	CVS-C3S	This cable extends the dedicated cable or the remote monitor cable. Up to 4 extension cables can be used (up to 15 m).

### Screen description: Color identification sensor

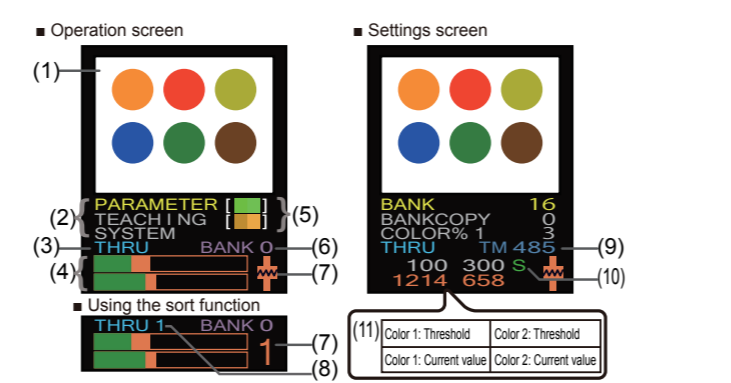

Number	Name	Explanation
(1)	Imaging screen	The image taken by the camera is displayed according to "Screen display mode."
(2)	Menu	Displays the settings and edit menus.
(3)	Screen display mode	Shows the current screen display mode (from THRU / COL1 / COL2 / COLR / LIVE).
(4)	Area bar graph	Displays the current area in a logarithmic graph (top: color 1, bottom: color 2). The orange-colored area represents the area upper and lower limits.
(5)	Detection color	The detection color on the left becomes the darkest color and the color on the right becomes the brightest (top: color 1, bottom: color 2).
(6)	Bank number	Displays the current bank number. (0 to 14)
(7)	Output status / Sorting number	Orange: Output ON, Green: Output OFF. Shows the sorted bank number when the sorting function is used (bottom figure).
(8)	Monitored bank number	Allows monitoring of the color and area of banks other than the current bank when the sorting function is used.
(9)	Response time	Represents the time between the start of imaging and when the output is issued (unit: 0.1 ms).
(10)	Communication status	Displays the communication status. S: Normal read command reception / response complete C: Normal setting command reception / response complete S: Data error in read command C: Data error in setting command ? : Incorrect command

(11)	Color area	Displays the threshold and current area for colors 1 and 2. Displayed in orange when the current area is within the upper/lower limit range, and displayed in green when outside the range.
------	------------	---

### Operation with the operating screen

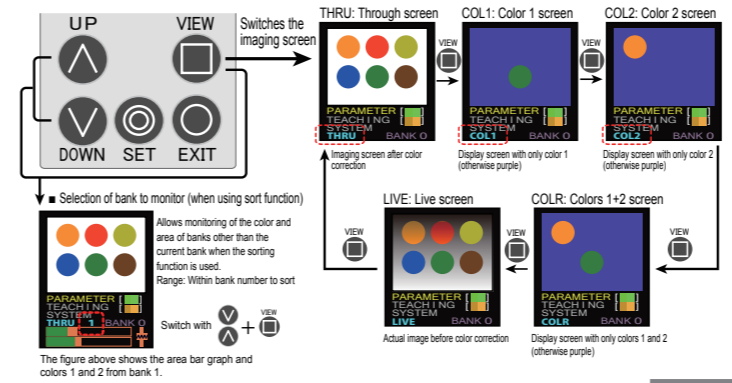

### How to check or change setting contents

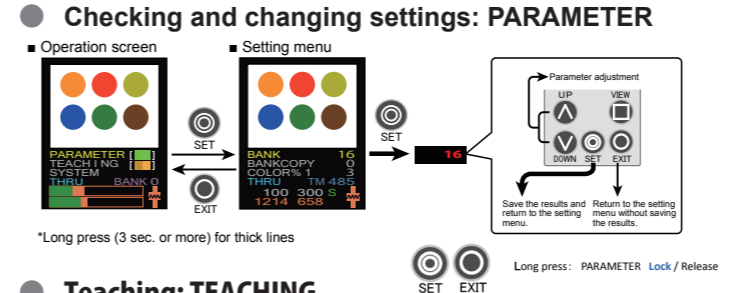

### Teaching: TEACHING

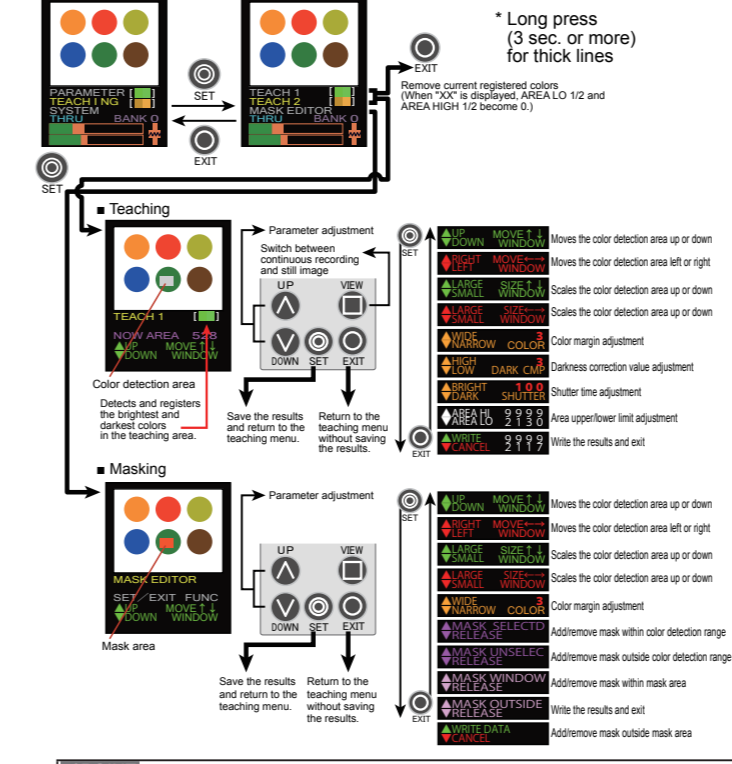

**POINT**  
Black is detected when black and bright colors are found in the color detection area. Set in this way, with black as the detection color, when detecting markings. The color 2 is not support in the teaching by the teaching input.

### System menu: SYSTEM

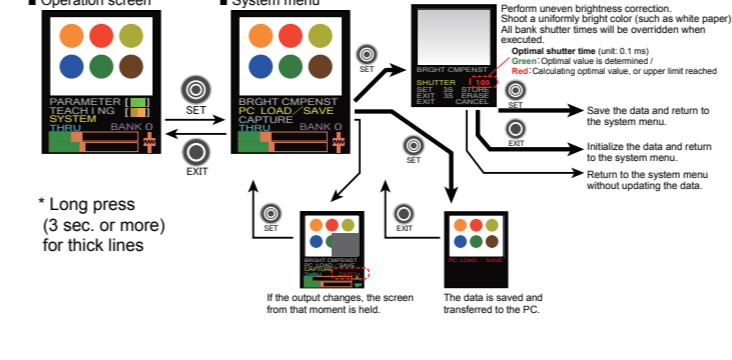

### Setting items

Set items list (Set values for purple set items are maintained for each bank)

Function name	Screen display	Setting range (Initial value)	Function
Color range for color 1	COLOR% 1	0 to 25 (1)	Sets the margins for color 1. Increasing this value will detect a wider range of colors.
Color range for color 2	COLOR% 2	0 to 25 (1)	Sets the margins for color 2. Increasing this value will detect a wider range of colors.
Communication speed	COMMUNIC	0 to 5 (0)	Sets the communication speed. *Data length: 8 bit, parity: none, stop bit: 1 bit 0: Communication is not used (usable with external lights and remote monitors) 1: 4.8 kbps / 2: 9.6 kbps / 3: 19.2 kbps / 4: 38.4 kbps / 5: 57.6 kbps
Operation mode	CVS1	0, 1 (1)	0: Operates as a pattern-matching sensor (see reverse). 1: Operates as a color identification sensor. *After changing settings, the settings will take effect once the power is turned off and then back on.
Darkness correction	DARK CMP	0 to 31 (27)	Corrects the darkness of a color. 0: No correction Suitable for detecting brightness differences between white, gray, and black. 31: Max. correction Suitable for determining subtle color differences in darker colors.
Camera gain	IMG GAIN	0 to 63 (0)	Sets the sensitivity (gain) of the imaging sensor. Increasing this value will reduce shutter time but will also increase noise.
Initialization	INITIALZ	0 to 15 (0)	Setting to 15 and then powering up while pressing "UP" and "DOWN" will initialize the set values, all data in the mask screen, and uneven brightness correction data. 10: All set values will be locked. 11: All lock statuses will be released. (When this item is locked, press and hold SET+EXIT buttons first)
Display orientation	LCD VIEW	0, 1 (0)	0: Normal LCD display 1: Flip LCD display vertically used to mount this unit with the top screen oriented downward.
Built-in light	LIGHT ON	0 to 15 (7)	Sets the brightness of the built-in light. 0: 0% and higher, 7: 50% and higher, 15: 100%
Illumination output	LIGHTOUT	0, 1 (0)	0: The auxiliary output (red/black wire) is used as the sorting output. 1: The auxiliary output is used as the illumination control output synchronously turned on with imaging.
OFF delay time	OFFDELAY	0 to 5000 (0)	Turns the output OFF when the area judgment result is outside the set time range (unit: ms).
ON delay time	ON DELAY	0 to 5000 (0)	Turns the output ON when the area judgment result is within the set time range (unit: ms).
One-shot output	ONESHOT	0, 1 (0)	1: After the output turns ON, the output stays ON only as long as the off delay time is "0," the output will remain ON until the bank is selected.
Output conditions	OUTSIDE	0 to 3 (0)	Sets the ON/OFF conditions for the output. 0: Colors 1 and 2 are both within the area upper/lower limit range 1: Either color 1 or 2 is within the area upper/lower limit range 2: Either color 1 or 2 is outside the area upper/lower limit range 3: Colors 1 and 2 are both outside the area upper/lower limit range
Resolution	RESOLUTN	0 to 2 (0)	Sets the pixel fineness and the imaging range. 0: High resolution (208×236) 1: High speed (104×236) 2: Narrow field of view (208×236: 2x zoom)
Screen size	SCREEN	0 to 3 (0)	Sets the size of the image taken from the imaging sensor. 0: 208×236 1: 160×236 2: 112×236 3: 64×236 *The fewer the pixels means a faster response time, but the imaging range will be narrow.
Shutter time	SHUTTER	0 to 261 (100)	Sets the shutter time (unit: 0.1 ms). *It is not possible to set a shutter time longer than the image transfer time of the imaging sensor.
Sort function	SORTING	0 to 14 (0)	0: Sorting will not be performed. 1 to 14: Sorting is performed for the number of settings + one type. Example: If the current bank is 5 and sorting is 2, the colors and areas of banks 5 to 7 are examined and output. If multiple banks apply, the bank of the smallest number is given priority. The setting values of each bank are applied to the current bank. When using the sorting function, perform teaching with all settings the same.
Synchronization input	SYNCHRON	0, 1 (1)	0: While synchronous input is OFF 1: When synchronous input goes from ON to OFF 2: While synchronous input is ON 3: When synchronous input goes from OFF to ON 4: Always *The purple wire acts as "synchronous input."
Teaching function enabled	TEACHENA	0 to 2 (0)	Sets the permissions for performing teaching, mask editing, uneven brightness correction, and PC communication. 0: All permitted / 1: Teaching (TEACH1, TEACH2) only permitted 2: All prohibited
Temperature compensation level	TEMPCOMP	0 to 50 (15)	This is the temperature compensation level for the imaging sensor. Adjust this value when the taught color shifts when the temperature rises. Correction will not be performed when set to 0.
Teach window	WINDOW	0, 1 (0)	Displays the corresponding location of the color from external teaching. 1: Displays the color detection area when on the THRU screen (excluding system menus).
Language selection	LANGUAGE	0, 1 (0)	Selects the language of the menus. 0: English / 1: Japanese (kana)
Lower limit for color 1	AREA LO1	0 to 9999 (1)	This is the lower limit for the detection area for color 1.
Lower limit for color 2	AREA LO2	0 to 9999 (0)	This is the lower limit for the detection area for color 2.
Upper limit for color 1	AREA HI1	0 to 9999 (0)	This is the upper limit for the detection area for color 1. *A set value of "0" operates the same as with "9999."
Upper limit for color 2	AREA HI2	0 to 9999 (0)	This is the upper limit for the detection area for color 2. *A set value of "0" operates the same as with "9999."
Bank	BANK	0 to 17 (16)	0 to 14: Switches to the specified bank. 15 to 17: Bank selection via external input (see I/O circuit diagram for details).
Bank copy	BANKCOPY	0 to 14 (0)	Click this button to copy the current bank settings to the specified bank.

### Sorting number reading

Using auxiliary output and judgment output  
Use 2 output lines to obtain sort numbers for 3 types. Output is performed in order beginning with the current bank number, as follows, with subsequent sequences repeating this order.

Bank number	Judgment output (black)	Auxiliary output (red/black)
Current	ON	OFF
+1	OFF	ON
+2	ON	ON

Using communication function  
Communication using RS232C is possible by connecting a dedicated cable (CVS-C2C) to the external connection connector. With this communication, up to 15 types of sorted bank numbers can be read. \*255 is returned when sorting is not applied.  
In addition, when performing external teaching, responses may take 3 seconds or longer.

Sorting number reading protocol

- Command (53H) / Teaching (49H) / Checksum (63H): PC → CVS2
- Response (06H) / Lower sort number (0 to 14/255) / Higher sort number (0/255) / Checksum: CVS2 → PC
- \* Checksum = Complement of 1 of (06H + Higher sort number + Lower sort number)



## Screen description: Pattern matching sensor

### Operation screen

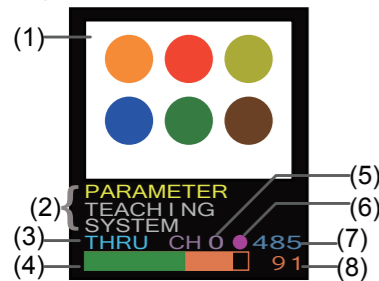

Number	Name	Explanation
(1)	Imaging screen	The image taken by the camera is displayed according to "Screen display mode."
(2)	Menu	Displays the settings and edit menus.
(3)	Screen display mode	Shows the current screen display mode (from THRU / LIVE / COLR / TRNS / PTRN / COMP).
(4)	Degree of matching bar graph	Shows the degree of matching. The green and orange boundary represents the threshold.
(5)	Bank number	Displays the current bank number. (0 to 14)
(6)	Auxiliary output status	• is displayed when the output is ON.
(7)	Response time	Shows the time between imaging and judgment output (unit: 0.1 ms).
(8)	Degree of matching / Output status	Displays the degree of matching (0 to 100) and the output status (ON: orange, OFF: green).

### Screen display mode types and switching between modes

The displayed content changes every time the "View" button is pressed.

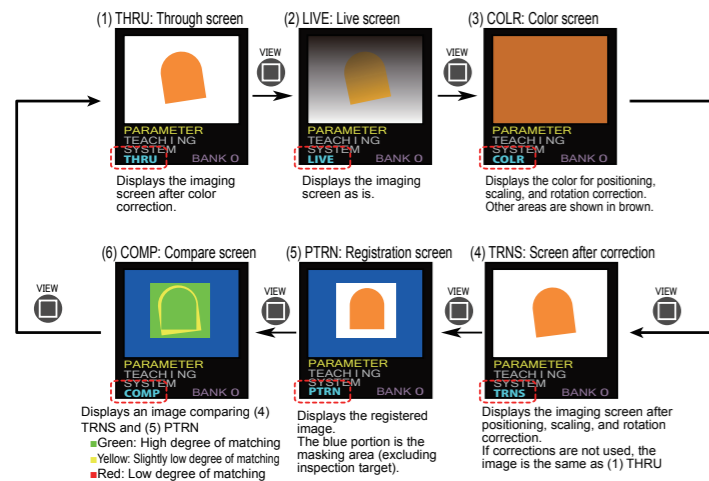

## Pattern (shape) registration and matching

### Reference pattern registration: SAVE PATTERN

A pattern (shape) is registered as a reference to be used for pattern matching. Detection is performed according to the "degree of matching" of the registered reference pattern and the current image.

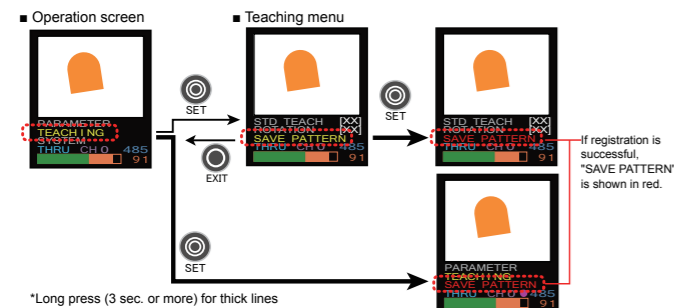

### Position correction, Scaling correction: STD TEACH

Setting the position correction and scaling correction helps with workpiece position shifting. With the correction function, a color and pattern for correction are registered, and correct the color's shape and size to become the same as those of the reference pattern.

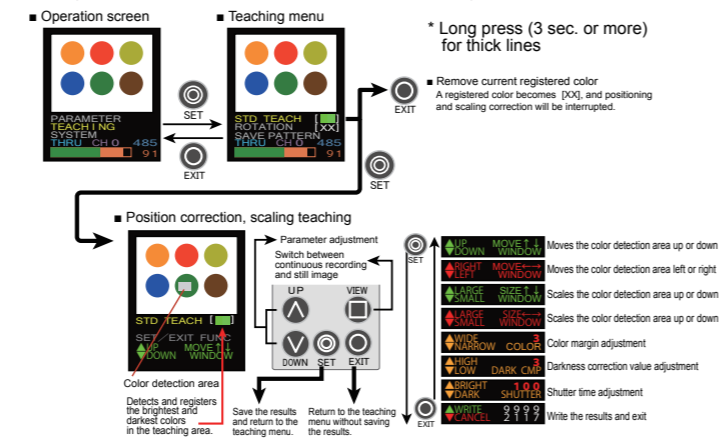

**POINT**  
For a registered color, select a color which is not in the base and always has the same size. By registering a chromatic color (a color other than white, gray, and black), stable detection is possible even if the brightness changes.

### Rotation correction: ROTATION

This setting configures the rotation correction for responding to workpiece rotation. To use rotation correction, it is necessary to have position correction and scaling correction registration completed beforehand. Rotation correction can be accessed from "Rotation" in the teaching menu. The menu items and operation details are the same as for positioning and scaling adjustments.

**POINT**  
If the center position is close to that of a color for positioning and scaling adjustment, significant errors during rotation correction will occur. Select a color in a location as distant as possible.

### Mask: MASK EDITOR

Registering areas not used for detection as "Masks" is possible. It's also possible to remove registered mask areas. With the initial settings, the area outside the center of the measurement area will be masked. Adjust this area as necessary.

The registered mask area will be shown as a blue region, as in (5) PTRN screen and (6) COMP screen.

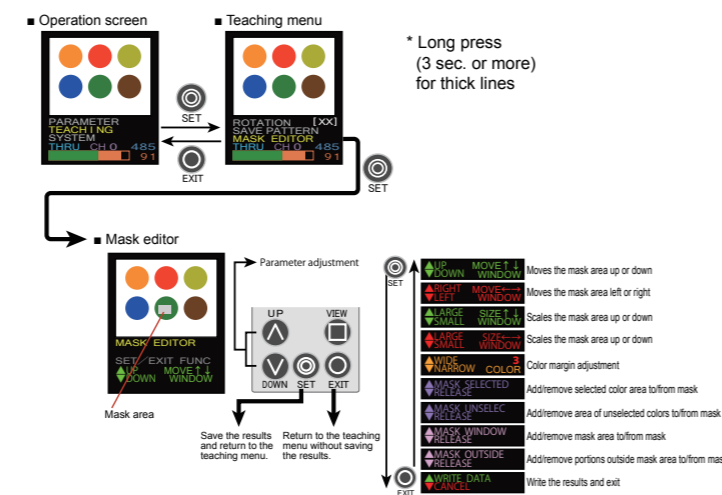

### Color detection area editing: COLOR WINDOW

Sets the area for detecting colors with positioning and scaling correction and rotation correction.



## Setting items

Set items list (Set values for purple set items are maintained for each bank)

Function name	Screen display	Setting range (Initial value)	Function
Fine adjustment of position	ADJ POS	0 to 28 (0)	Moves/rotates the captured image and applies the results with the highest degree of matching. 0: No fine adjustment 1: Moves ±1 pixel up, down, left, or right 2: Moves ±1 pixel up, down, left, or right, and ±1 pixel up diagonally 3: Moves ±1 pixel up, down, left, or right, and ±1 pixel or ±2 pixels up diagonally 4 to 9: Rotates at ±1.4° intervals until (set value - 3) × 1.4° is reached 10 to 19: Rotates at ±2.8° intervals until (set value - 3) × 2.8° is reached 20 to 28: Rotates at ±7° intervals until (set value - 3) × 7° is reached * Use 1 to 3 for determining character correctness.
Matching / Chip sensitivity	C M P LACK	0 to 15 (0)	0: Calculates the degree of matching by averaging the degree of matching of the pixels in the entire detection area (unmasked portion). 1 to 15: A higher value corresponds to a higher sensitivity to different colored pixels. Used when inspecting for scratches and chips.
Threshold	CMP LEVEL	0 to 100 (70)	Sets the degree of matching to serve as a reference for turning the output ON/OFF. A higher number requires a higher degree of matching. Because a negative degree of matching is processed internally, output may not turn ON even if the threshold is set to "0."
Color sensitivity	C M P SENSE	0 to 15 (10)	Sets the sensitivity for color differences. A higher number sets a higher sensitivity for determining subtle color differences.
Position correction color palette	C O L O P %P	0 to 25 (1)	Sets the detection margin for the teaching color set through position correction. Setting a large number will target a wide range of colors for detection.
Rotation color palette	C O L O R %R	0 to 25 (1)	Sets the detection margin for the teaching color set through rotation correction. Setting a large number will target a wide range of colors for detection.
Darkness correction	D A R K CMP	0 to 31 (0)	Corrects the darkness of a color. 0: No correction Suitable for detecting brightness differences between white, gray, and black. 31: Max. correction Suitable for determining subtle color differences in darker colors.
Camera gain	IMG GAIN	0 to 63 (0)	Sets the sensitivity (gain) of the imaging sensor. Increasing this value will reduce shutter time but will also increase noise.
Scaling correction	MAGNIFY%	0 to 127 (0)	0 / No registered position or rotation correction: No scaling correction 1 to 127: Scaling performed up to 128 / (128 ± set value) Example: 0.76x to 1.45x when set to 40 • Position or rotation correction is not registered: Correction based on distance of each color • Only color for position correction registered: Correction based on area of color for position correction
X position correction (Horizontal)	POSIT% X	0 to 208 (104)	0 / No registration of color for correction: No horizontal position correction 1 to 208: Position correction performed for the set number of pixels (horizontal direction)
Y position correction (Vertical)	POSIT% Y	0 to 236 (118)	0 / No registration of color for correction: No vertical position correction 1 to 236: Position correction performed for the set number of pixels (vertical direction)
Rotation correction	ROTATE%	0 to 180 (180)	0 / No registered position or rotation correction: No rotation correction 1 to 180: Rotation corrected up to ± the set value (in degrees)
Shutter time	SHUTTER	0 to 261 (100)	Sets the shutter time (unit: 0.1 ms). *It is not possible to set a shutter time longer than the image transfer time of the imaging sensor.
Temperature compensation level	TEMPCMP	0 to 50 (15)	This is the temperature compensation level for the imaging sensor. Adjust this value when the taught color shifts when the temperature rises. Correction will not be performed when set to 0.
Teaching function enabled	TEACHENA	0 to 2 (0)	Sets the permissions for performing teaching, mask editing, uneven brightness correction, and PC communication. 0: All permitted / 1: Screen registration only permitted 2: All prohibited
Synchronous input	SYNCHRON	0 to 3 (0)	0: While synchronous input is OFF 1: When synchronous input goes from ON to OFF 2: While synchronous input is ON 3: When synchronous input goes from OFF to ON 4: Always *The purple wire acts as "synchronous input" and the response time is doubled.
Screen size	SCREEN	0 to 3 (0)	Sets the size of the image taken from the imaging sensor. 0: 208×236 1: 160×236 2: 112×236 3: 64×236 *The fewer the pixels means a faster response time, but the imaging range will be narrow.
Resolution	RESOLUTN	0 to 2 (0)	Sets the pixel fineness and the imaging range. 0: High resolution (208×236) 1: High speed (104×236) 2: Narrow field of view (208×236: 2x zoom) *Because changing this value will change the brightness/int, perform teaching again.
Output setting	OUTSIDE	0,1 (1)	0: Output is ON when degree of matching is greater than or equal to the threshold and OFF when less than the threshold. 1: Output is OFF when degree of matching is greater than or equal to the threshold and ON when less than the threshold.
One-shot output	ONESHOT	0,1 (0)	1: After the output turns ON, the output stays ON only as long as the off delay time. If the off delay time is "0", the output will remain ON until the bank is selected.
ON delay time	ON DELAY	0 to 5000 (0)	Turns the output ON when the judgment result is ON for a period longer than the set time (ms).
OFF delay time	OFFDELAY	0 to 5000 (0)	Turns the output OFF when the judgment result is OFF for a period longer than the set time (ms).
Illumination output	LIGHTOUT	0,1 (0)	0: The auxiliary output (red/black wire) is used as the auxiliary output line. 1: The auxiliary output is used as the illumination control output synchronously turned on with imaging.
Built-in light	LIGHT ON	0 to 15 (7)	Sets the brightness of the built-in light. 0: 0% and higher, 7: 50% and higher, 15: 100%
Display orientation	LCD VIEW	0,1 (0)	0: Normal LCD display 1: Flip LCD display vertically Used to mount this unit with the top screen oriented downward.
Initialization	INITIALZ	0 to 15 (0)	Setting to 15 and then powering up while pressing "UP" and "DOWN" will initialize the set values, all data in the mask screen, and uneven brightness correction data. 10: All set values will be locked. 11: All lock statuses will be released. (When this item is locked, press and hold SET+EXIT buttons first)
Operation mode	CVS1	0,1 (1)	0: Operates as a pattern-matching sensor. 1: Operates as a color identification sensor (see reverse). *After changing settings, the settings will take effect once the power is turned off and then back on.
Communication speed	COMMUNIC	0 to 5 (0)	Sets the communication speed. *Data length: 8 bit, parity: none, stop bit: 1 bit 0: Communication is not used (usable with external lights and remote monitors). 1: 4.8 kbps / 2: 9.6 kbps / 3: 19.2 kbps / 4: 38.4 kbps / 5: 57.6 kbps
Bank copy	BANKCOPY	0 to 14 (0)	Click this button to copy the current bank settings to the specified bank.
Bank	BANK	0 to 17 (16)	0 to 14: Switches to the specified bank. 15 to 17: Bank selection via external input (see I/O circuit diagram for details). *When 16 or 17 is set, the input terminal operation is validated when "AUX OUT = 4" is set.
Auxiliary output	AUX OUT	0 to 4 (4)	0: Turns OFF with bank selection input and ON upon the first judgment after bank selection. Turns ON upon completion of the first imaging after the power is turned ON. 1: Output is repeatedly turned ON/OFF for each judgment. 2: Transmits an output signal to external lighting. 3: Turns ON when the tolerances for positioning, scaling, and rotation correction are all within the setting range. 4: The auxiliary output signal line is used as an input (when the BANK setting is 16 or 17).

Language selection	LANGUAGE	0,1 (0)	Selects the language of the menus. 0: English / 1: Japanese (kana)
--------------------	----------	---------	---

### Checking and changing settings:PARAMETER

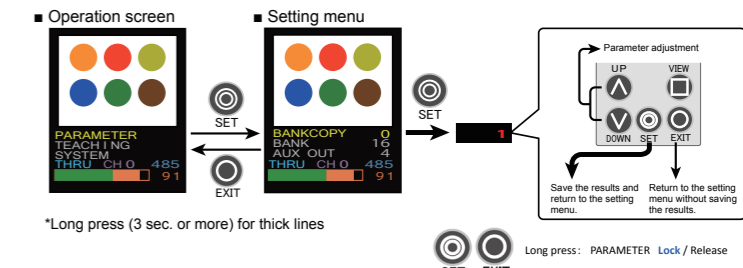

Sample workpiece

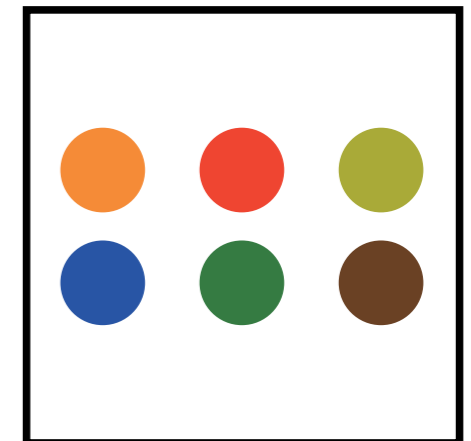
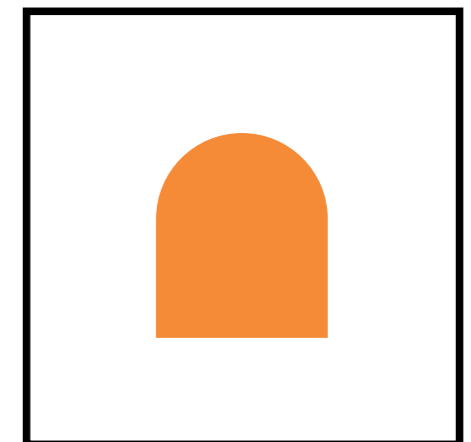

• Product specifications are subject to change without prior notice.  
• For more information, questions, or comments regarding this product, please contact us by any of the following means.

For China RoHS, please refer to [http://www.optex-fa.com/rohs\\_cn/](http://www.optex-fa.com/rohs_cn/).

Manufactured and sold by :

**OPTEX FA CO.,LTD.**

Headquarters: 4F, Kyoto Research Park Building No. 9,  
91, Chudoji-Awata-cho, Shimogyo-ku, Kyoto 600-8815, JAPAN  
TEL: +81-(0)75-325-1314 FAX: +81-(0)75-325-2921

OPTEX FA Homepage

<http://www.optex-fa.com>