

VISOR® V10 Color

Standard vision sensor for object detection, colour, 6 mm



PRODUCT HIGHLIGHTS

- Object detection in colour
- Reliable detection of very slight colour nuances or self-illuminating components
- Powerful part finding and tracking
- User-friendly configuration and viewer software with hierarchical user rights

Optical data		Functions	
Resolution	736 x 480 pixels	Number of jobs / detectors	8 / 32
CMOS	1/3", colour	Detectors	Position tracking X/Y and orientation via contour inspection; colour area
Integrated lens, focal length	6 mm, adjustable focal position	Properties	Position tracking X/Y and orientation; contour: teach-in and detection of contours; colour area: two-dimensional colour inspection with adjustable tolerance
Adjustment range	6 mm to infinity	Typical cycle times	Typ. 30 ms position tracking Typ. 30 ms colour area
Integrated illumination	White LEDs		
Minimum field of view, X x Y	5 x 4 mm ²		
Electrical data		Mechanical data	
Operating voltage, +U _B	18 ... 26.4 V DC ¹	Dimensions	65 x 45 x 45 mm (without plug)
Current consumption (without illumination and I/O)	≤ 120 mA	Enclosure rating	IP 67
Current consumption (without I/O)	≤ 200 mA	Material, housing	Aluminium, plastic
Protective circuits	Reverse-polarity protection, U _B / short-circuit protection of all outputs	Material, front screen	Plastic
Power On Delay	Approx. 13 s after Power on	Ambient temperature: operation	0 ... +50 °C ²
Outputs	PNP / NPN (switchable)	Ambient temperature: storage	-20 ... +60 °C ²
Max. output current (per output)	50 mA, 100 mA (pin 12)	Weight	Approx. 160 g
Inputs	PNP/NPN High > U _B -1 V, Low < 3 V	Plug connections	Supply and I/O M12, 12-pin Ethernet M12, 4-pin
Input resistance	> 20 kOhm	Vibration and impact resistance	EN 60947-5-2
Interfaces	Ethernet (LAN), EtherNet/IP, PROFINET, SensoWeb		
Inputs/outputs	2 inputs, 4 outputs, 2 selectable inputs/outputs		

¹ Max. ripple < 5 V_{SS} ² 80 % air humidity, non-condensing

Illumination	Depth of field	Part number	Article number
White	Normal	V10C-CO-S2-W6	535-91071

VISOR® vision sensor

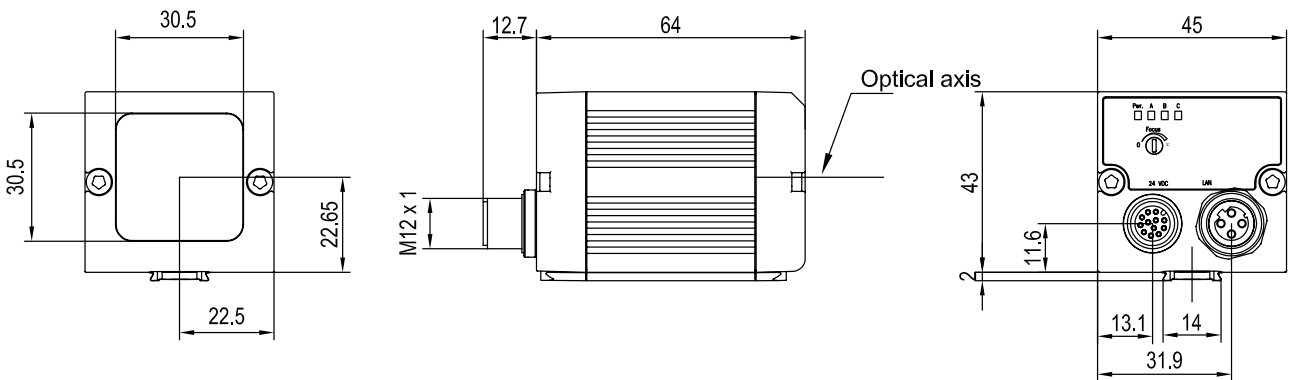

153-01030

4

Field of view

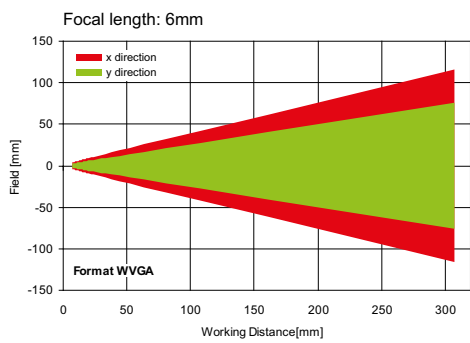

155-01422

Depth of field: normal

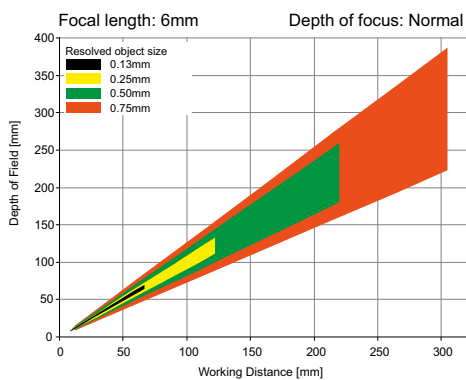

155-01409

Accessories

Connection cables	From Page A-38
Illumination	From Page A-30
Brackets	From Page A-14
Interface accessories	From Page A-42