



Operating Instructions  
**MD6-22**

Mobile, Capacitive Measuring Gauge

MICRO-EPSILON  
MESSTECHNIK  
GmbH & Co. KG  
Koenigbacher Str. 15

94496 Ortenburg / Germany

Tel. +49 (0) 8542 / 168-0  
Fax +49 (0) 8542 / 168-90  
e-mail [info@micro-epsilon.com](mailto:info@micro-epsilon.com)  
[www.micro-epsilon.com](http://www.micro-epsilon.com)

---

# Inhalt

<b>1.</b>	<b>Safety .....</b>	<b>5</b>
1.1	Symbols Used .....	5
1.2	Warnings .....	5
1.3	Notice on CE Marking .....	6
1.4	Intended Use .....	7
1.5	Proper Environment .....	7
<b>2.</b>	<b>Functional Principle .....</b>	<b>8</b>
2.1	Measuring Principle .....	8
2.2	Structure .....	9
	2.2.1 Sensors .....	10
	2.2.2 Sensor Cable .....	10
	2.2.3 Controller Operating Elements and Connections .....	11
2.3	Technical Data .....	12
<b>3.</b>	<b>Delivery .....</b>	<b>15</b>
3.1	Unpacking, Included in Delivery .....	15
3.2	Storage .....	15
3.3	Handling Magnets .....	16
<b>4.</b>	<b>Dimensional Drawing .....</b>	<b>17</b>
4.1	Precautionary Measures .....	17
4.2	Sensor, Sensor cable .....	17
4.3	Controller .....	19
4.4	Holding magnet .....	20
4.5	Ground Connection, Earthing .....	20
4.6	Sensor Connection .....	20
<b>5.</b>	<b>Operation .....</b>	<b>21</b>
5.1	Overview of Measured Values .....	21
5.2	Software Operation .....	22
	5.2.1 Operating Elements on the Touch Display .....	22
	5.2.2 Status Headline .....	22

---

<b>6.</b>	<b>Measuring Programs</b> .....	<b>23</b>
6.1	Single-Sided Gap Measurement .....	23
	6.1.1 Basic Settings .....	23
	6.1.2 Instant Measurement .....	24
	6.1.3 Manual Gap Detection .....	27
	6.1.4 Automatic Gap Detection.....	31
6.2	Double-Sided Gap Measurement (Minimum) .....	34
	6.2.1 Basic Settings .....	34
	6.2.2 Instant Measurement .....	35
	6.2.3 Manual Gap Detection .....	38
	6.2.4 Automatic Gap Detection.....	42
6.3	Double-Sided Gap Measurement (Maximum) .....	46
	6.3.1 General.....	46
	6.3.2 Basic Settings .....	46
	6.3.3 Instant Measurement .....	47
	6.3.4 Manual Gap Detection .....	50
	6.3.5 Automatic Gap Detection.....	54
6.4	Single-value measurement with math function .....	58
	6.4.1 Basic Settings .....	58
	6.4.2 Calculation .....	59
	6.4.3 Single-value measurement with math function .....	61
6.5	Device Information, Date and Time .....	62
6.6	Measurement with Reference Gap.....	63
6.7	Relative Measurement .....	65
<b>7.</b>	<b>Maintenance</b> .....	<b>67</b>
<b>8.</b>	<b>Liability for Material Defects</b> .....	<b>68</b>
<b>9.</b>	<b>Decommissioning, Disposal</b> .....	<b>68</b>

## 1. Safety

System operation assumes knowledge of the operating instructions.

### 1.1 Symbols Used

The following symbols are used in these operating instructions:



Indicates a hazardous situation which, if not avoided, could result in death or serious injury.



Indicates a hazardous situation which, if not avoided, may result in minor or moderate injury.



Indicates a situation that may result in property damage if not avoided.



Indicates a user action.



Indicates a tip for users.

Measure

Indicates hardware or a software button/menu.

### 1.2 Warnings



The positioning system includes holding magnets. Persons with pacemakers or implanted defibrillators absolutely must keep a sufficient distance from the magnets.

> Risk of injury

Only push the shielding discs off the holding magnet from the side. Crushing of limbs is possible.

> Risk of injury

**NOTICE**

Avoid shocks and impacts to the sensor and controller.

> Damage to or destruction of the sensor and controller.

The charging voltage must not exceed or continuously fall below the specified limits.

> Damage to or destruction of the sensor and/or controller

Protect the sensor cable against damage.

- > Destruction of the sensor
- > Failure of the measuring device

Magnets create a magnetic field. They can interfere with or damage electronic devices, measuring devices, computer hard drives, credit cards and ATM cards, among other things.

- > Damage or destruction possible

### **1.3 Notice on CE Marking**

The following apply to the capaNCDT MD6-22:

- EU Directive 2014/30/EU
- EU Directive 2011/65/EU, „RoHS“ category 9

Products which carry the CE mark satisfy the requirements of the EU directives cited and the European harmonized standards (EN) listed therein. The measuring system is designed for use in industrial environments and meets the requirements.

The EU Declaration of Conformity is available to the responsible authorities according to EU Directive, article 10.

#### 1.4 Intended Use

- The capaNCDT MD6-22 is designed for use in industrial, laboratory and residential applications. It is used for mobile distance and gap measurements.
- The measuring system must only be operated within the limits specified in the technical data, see Chap. [2.3](#).
- The measuring system must be used in such a way that no persons are endangered or machines and other material goods are damaged in the event of malfunction or total failure of the sensor.
- Take additional precautions for safety and damage prevention in case of safety-related applications.

#### 1.5 Proper Environment

- Protection class: IP 30
- Temperature range
  - Operation:
    - Sensor, sensor cable: -25 ... +85 °C (-13 ... +185 °F)  
-40 ... +100 °C (-40 ... +212 °F) (< 10.000 h)
    - Controller: +10 ... +50 °C (+10 ... +122 °F)
  - Storage:
    - Sensor, sensor cable: -25 ... +85 °C (-13 ... +185 °F)
    - Controller: -10 ... +65 °C (+14 ... +149 °F)
- Humidity: 5 - 95 % (non-condensing)
- Ambient pressure: Atmospheric pressure
- The space between the sensor surface and the target must have an unvarying dielectric constant.
- The space between the sensor surface and the target may not be contaminated (for example water, rubbed-off parts, dust, etc.).

## 2. Functional Principle

### 2.1 Measuring Principle

The principle of capacitive distance measurement with the capaNCDT system is based on the principle of the parallel plate capacitor. For conductive targets, the sensor and the target opposite form the two plate electrodes.

If a constant AC current flows through the sensor capacitor, the amplitude of the AC voltage at the sensor is proportional to the distance between the capacitor electrodes.

The capaNCDT system evaluates the reactance  $X_c$  of the plate capacitor which changes strictly in proportion to the distance:

$$X_c = \frac{1}{j\omega C}; \text{ capacitance } C = \epsilon_r * \epsilon_0 * \frac{\text{area}}{\text{distance}}$$

**i** A small target and bent (uneven) surfaces cause a non-linear characteristic.

The linear characteristic of the measuring signal is achieved for electrically conductive target materials (metals) without any additional electronic linearization.

Slight changes in the conductivity or magnetic properties do not affect the sensitivity or linearity.

The flat sensors are guided into the gap and determine the gap width based on the active measuring area.

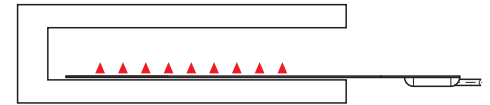

*Fig. 1 Single-sided gap measurement with CSFx sensor*

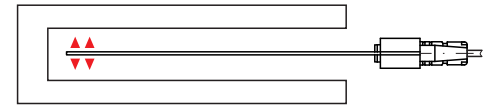

*Fig. 2 Double-sided gap measurement with CSGx sensor*





## 2.2 Structure

The non-contact MD6-22 dual-channel handheld gauge installed in a plastic housing consists of:

- Controller
- Sensor
- Sensor cable

The signal processing electronics with oscillator and integrated preamplifier is in the controller.

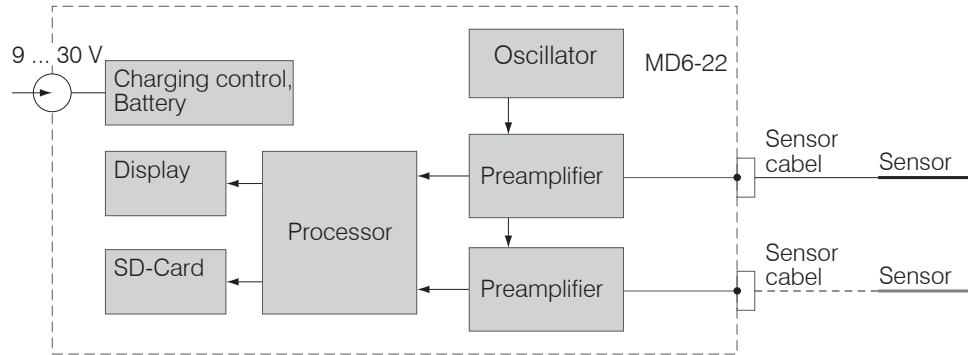

Fig. 3 Block diagram MD6-22

### 2.2.1 Sensors

For this measurement system, several sensors can be used.

➡ In order to obtain accurate measuring results, keep the surface of the sensor clean and free from damage.

The capacitive measuring process is area-related. A minimum area is required depending on the sensor model and measuring range (see table).

Sensors for electrical conducting targets (metals)

Model	CSF2-CRG4,0	CSF4-CRG4,0	CSF6-CRG4,0
Measuring range	4 mm	8 mm	12 mm
Min. target size (flat)	approx. 50.5 x 14 mm	approx. 90.5 x 17.5 mm	approx. 127.31 x 25 mm

Model	CSG0,5-CAm2,0	CSG1,0-CAm2,0
Measuring range	1 mm	2 mm
Min. target size (flat)	approx. 9.9 x 15 mm	

### 2.2.2 Sensor Cable

Sensor and controller are connected by a special, double screened sensor cable. Do not shorten or lengthen these special cables.

Usually, a damaged cable can not be repaired.

Switch of the device when plugging and removing connectors.

Do not crush the sensor cable.

Do not modify to the sensor cable.

> Loss of functionality

**NOTICE**

### 2.2.3 Controller Operating Elements and Connections



- 1 On/Off switch  
Switch on: briefly press the button.  
Switch off: keep the button pressed for more than 3 seconds.
- 2 Sensor connections
- 3 Connection socket for ground connection. When using CSFxx/CSGxx sensors, a ground connection to the measurement object is required to ensure a stable measurement signal.
- 4 LED for battery state of charge  
The LED is illuminated while the battery is being charged.
- 5 Mini USB  
Internal use
- 6 MicroSD card (max. 32 GB)  
MicroSD or microSDHC card to store the protocol
- 7 Supply  
Power supply unit for battery charging or for operation without batteries
- 8 Split ferrite  
Braid-breaker for interference suppression

Fig. 4 Characteristics MD6-22

## 2.3 Technical Data

<b>Model Controller</b>		<b>MD6-22</b>
Resolution (dynamic 100 Hz)		0.02 % FSO
Frequency response (-3dB)		100 Hz
Linearity		< $\pm 0.2$ % FSO
Temperature stability		< 200 ppm FSO / K
Sensitivity		$\leq \pm 0.2$ % FSO
Long-term stability		< 0.04 % FSO / month
Synchronization		yes
Connection		sensor: 2 x sockets type B
Temperature range	Operation	+10 ... +50 °C (+50 ... +122 °F)
	Storage	-10 ... +65 °C (+14 ... +149 °F)
Shock (DIN-EN 60068-2-27)		40 g / half-sine 6 ms in XYZ axes / 1000 shocks per axis
Vibration (DIN-EN 60068-2-64)		10 g / 10 ... 500 Hz in XYZ axes / 30 minutes per axis
Protection class (DIN-EN 60529)		IP30
No. of measurement channels		2
Weight		500 g (without magnetic holder)
Battery life		5 hours (with 2500 mAh)
Control and display element		touch display
Compatibility		compatible with all capaNCDT sensors
Features		2 synchronized measurement channels; storage of measured values on micro SD / SDHC card (included in delivery, max. storage capacity 32 GB)

FSO = Full Scale Output

<b>Model Sensor</b>	<b>CSF2-CRg4,0</b>	<b>CSF4-CRg4,0</b>	<b>CSF6-CRg4,0</b>
Measuring range	4 mm	8 mm	12 mm
Resolution <sup>1)</sup> dynamic (100 Hz)	0.8 $\mu\text{m}$	1.6 $\mu\text{m}$	2.4 $\mu\text{m}$
Linearity <sup>1)</sup>	< $\pm 8 \mu\text{m}$	< $\pm 16 \mu\text{m}$	< $\pm 24 \mu\text{m}$
Temperature stability <sup>2)</sup>	< 0.8 $\mu\text{m} / \text{K}$	< 1.6 $\mu\text{m} / \text{K}$	< 2.4 $\mu\text{m} / \text{K}$
Required gap width	$\geq 0.75 \text{ mm}$		
Min. target size (flat)	approx. 50.5 x 14 mm	approx. 90.5 x 17.5 mm	approx. 127.31 x 25 mm
Connection	integrated sensor cable; standard length 4 m		
Temperature range	Operation	-20 ... +85 °C (-4 ... +185 °F)	
	Storage	-20 ... +85 °C (-4 ... +185 °F)	
	Operation (< 10000 h)	-40 ... +100 °C (-40 ... +212 °F)	
Humidity <sup>3)</sup>	0 ... 95 % r.H.		
Shock (DIN-EN 60068-2-29) <sup>4)</sup>	30g / 5ms in XY axes / 1000 shocks per axis		
Vibration (DIN-EN 60068-2-6) <sup>4)</sup>	20g / 58 Hz...2000 Hz in XY axes / 10 cycles per axis		
Protection class (DIN-EN 60529)	IP40		
Material	hard tissue (GFRP)		
Weight                      incl. cable and plug	75 g	77 g	80 g

1) Valid when operated with MD6-22

2) Valid when system is not installed

3) Non-condensing

4) With locked connector

<b>Model Sensor</b>	<b>CSG0,5-CAm2,0</b>	<b>CSG1,0-CAm2,0</b>
Measuring range <sup>1)</sup>	1 mm	2 mm
Resolution <sup>2)</sup> dynamic (100 Hz)	0.4 $\mu\text{m}$	0.8 $\mu\text{m}$
Linearity <sup>2)</sup>	< $\pm 4 \mu\text{m}$	< $\pm 8 \mu\text{m}$
Temperature stability	< 0.4 $\mu\text{m} / \text{K}$	< 0.8 $\mu\text{m} / \text{K}$
Required gap width	$\geq 0.9 \text{ mm}$	
Min. target size (flat)	approx. 9.9 x 15 mm	
Connection	integrated sensor cable; standard length 2 m	
Temperature range	Operation	-50 ... +100 °C (-58 ... +212 °F)
	Storage	-50 ... +100 °C (-58 ... +212 °F)
Humidity <sup>3)</sup>	0 ... 95 % r.H.	
Shock (DIN-EN 60068-2-29) <sup>4)</sup>	30g / 5ms in XY axes / 1000 shocks per axis	
Vibration (DIN-EN 60068-2-6) <sup>4)</sup>	20g / 50 Hz...2000 Hz in XY axes / 10 cycles per axis	
Protection class (DIN-EN 60529)	IP40	
Material	hard tissue (GFRP)	
Weight                      incl. cable and plug	77 g	

1) Measuring range per measurement direction

2) Valid with operation with reference configuration

3) Non-condensing

4) With locked connector

### 3. Delivery

#### 3.1 Unpacking, Included in Delivery

- 1 Handheld gauge MD6-22
- 1 capaNCDT sensor with integrated cable (optional)
- 1 CD with operating instructions
- 1 Assembly instructions
- 1 Robust carry case
- 1 Power supply unit / international 24 VDC, 1A
- 1 Magnetic holder incl. Allen wrench for installation on cover of battery compartment
- 4 Batteries NiMH / Mignon (AA, HR6)
- 1 MicroSD card
- 1 Cable for ground connection

- ➡ Carefully remove the components of the measuring system from the packaging and ensure that the goods are forwarded in such a way that no damage can occur.
- ➡ Check the delivery for completeness and shipping damage immediately after unpacking.
- ➡ If there is damage or parts are missing, immediately contact the manufacturer or supplier.

#### 3.2 Storage

- Temperature range storage:
  - Sensor: -25 ... +85 °C (-13 ... +185 °F) (CSFx and CSGx)
  - Sensor cable: -50 ... +80 °C (-58 ... +176 °F)(CCgx and CCgx/90)
  - Controller: -10 ... +65 °C (+14 ... +149 °F)
- Humidity: 5 - 95 % RH (non-condensing)

### 3.3 Handling Magnets

The measuring system includes a magnetic holder.

Transport and store the holding magnet solely with the shielding disc on the holding magnet.



Caution! Risk of trapping!



Caution! Strong magnetic field!



Warning! Keep back!

Improper use of magnets can result in injuries and damage to property. Read the warnings, see Chap. 1.2.



## 4. Dimensional Drawing

### 4.1 Precautionary Measures

No sharp-edged or heavy objects may get into contact with the sensor cable sheath.

▶ Avoid kinks in any case. Check the connections for tight fit.

ⓘ A damaged cable cannot be repaired. Tension on the cable is not permitted!

### 4.2 Sensor, Sensor cable

During measurement, take care that the active measuring area is not scratched.

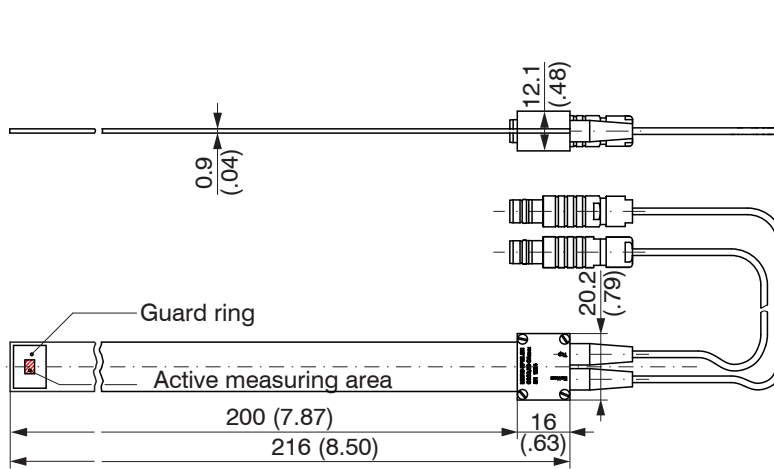
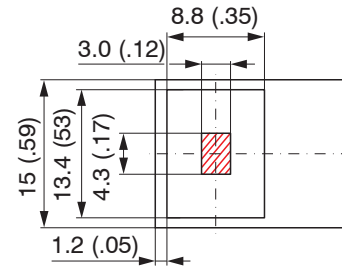
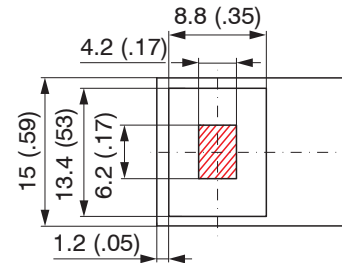

Fig. 5 Dimensional drawing CSGx-CAM2,0



Measuring area  
CSG0,5-CAM2,0



Measuring area  
CSG1,0-CAM2,0

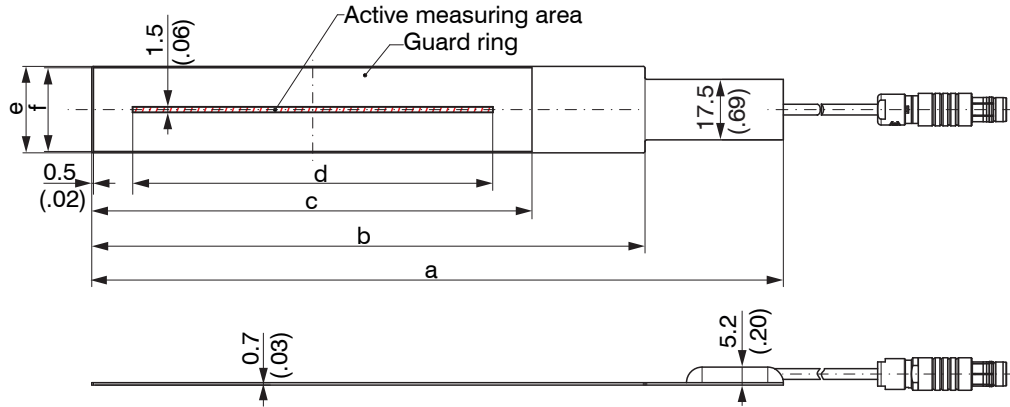

Model	CSF2-CRgx	CSF4-CRgx	CSF6-CRgx
a	120 (4.72)	160 (6.30)	200 (7.87)
b	88 (3.46)	-	160 (6.30)
c	50.5 (1.99)	90.5 (3.56)	127.31 (5.01)
d	34.7 (1.37)	69.4 (2.73)	104.1 (4.10)
e	14 (.55)	17.5 (.69)	25 (.98)
f	13 (.51)	16.5 (.65)	24.2 (.95)

Fig. 6 Dimensional drawing CSF<sub>x</sub>-CR<sub>gx</sub>

The sensor is connected to the controller by the sensor cable. The connection is made by simple plugging. The connector locks automatically. The tight fit can be checked by pulling the connector housing (cable bushing). The lock can be released and the connector can be opened by pulling the knurled housing sleeve of the cable bushing.

### 4.3 Controller

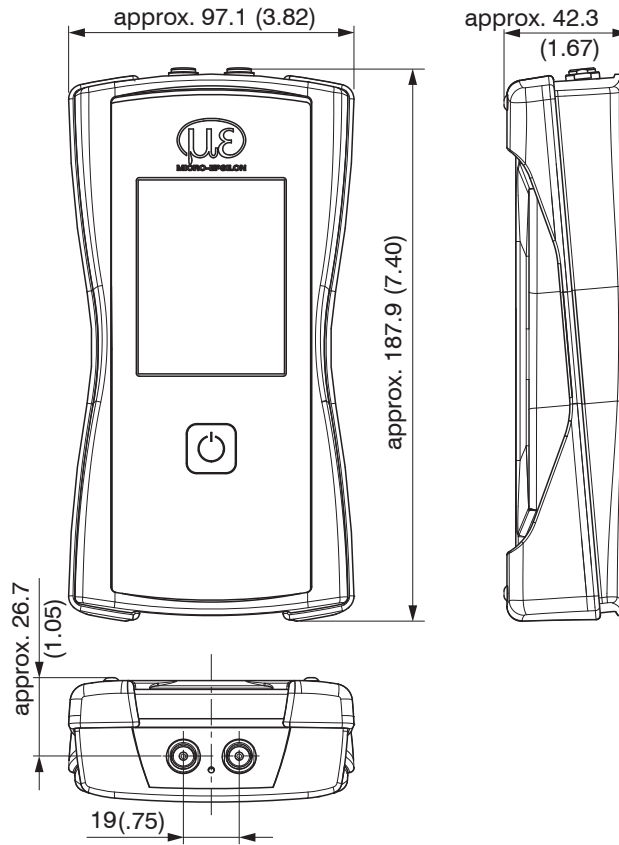

Fig. 7 Dimensional drawing Controller, dimensions in mm (inches), not to scale



Fig. 8 Controller with holding magnet on the bottom side

#### **NOTICE**

Damage to the controller by falling down.  
Uneven ground, product residues and rust layers reduce the holding force at the attachment point.

**⚠ WARNING**

Magnetic field.  
Injury possible.  
Persons with pace-  
makers or implanted  
defibrillators abso-  
lutely must keep a  
sufficient distance

**⚠ CAUTION**

Risk of pinching.  
Injury of fingers pos-  
sible. Only push the  
shielding disc off the  
holding magnet from  
the side.

**4.4 Holding magnet**

- ➡ Attach the controller at the measuring position. The sensors can be mounted using a holding magnet.
- ➡ Remove the shielding disc from the holding magnets. Push them off to the side.



*Fig. 9 Pushing the shielding disk off a holding magnet from the side*

**4.5 Ground Connection, Earthing**

Make sure you have a sufficient grounding of the measuring object.

- ➡ Connect controller and measured object using the supplied connecting cable, see [Fig. 10](#).

**i** Do not extend the cable for the ground connection!

**4.6 Sensor Connection**

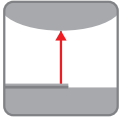
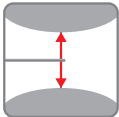
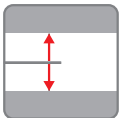
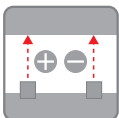

*Fig. 10 Sensor cable connection*

## 5. Operation

### 5.1 Overview of Measured Values

**i** The handheld gauge is immediately ready for use. To ensure precise measurements, the measuring system should warm up approx. 10 minutes after switching on.

Measuring program	Sensor 1	Sensor 2	
Gap Measure (1-sided), see Chap. 6.1	x	o	
Gap Measure (2-sided) Min, see Chap. 6.2 for bent surfaces	x	x	
Gap Measure (2-sided) Max, see Chap. 6.3 for straight surfaces	x	x	
Raw Data Measure, see Chap. 6.4	x	o	

x Standard

o Optional

If the sensor is tilted in the measuring gap, measurements might be inaccurate. Therefore, insert the sensor as parallel as possible into the measuring gap.

## 5.2 Software Operation

### 5.2.1 Operating Elements on the Touch Display

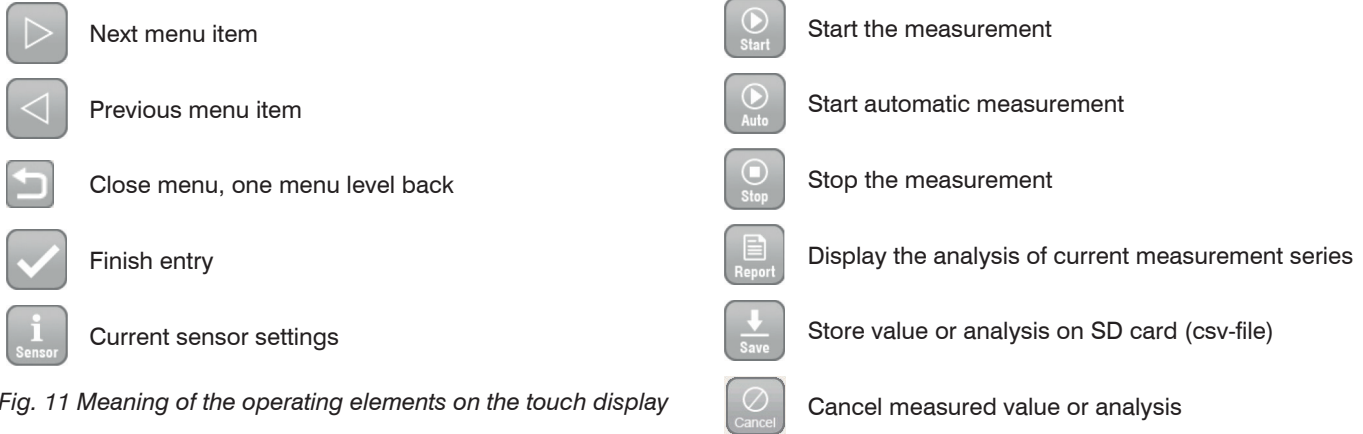



Fig. 11 Meaning of the operating elements on the touch display

### 5.2.2 Status Headline

#### Data/Time

16.04.2019 15:34:05   12%

#### Status SD Card

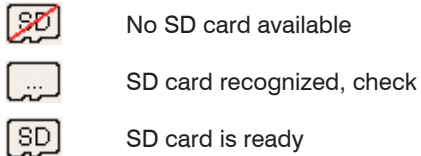

#### Battery state of charge

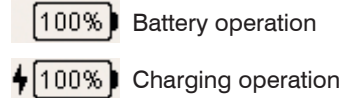

## 6. Measuring Programs

### 6.1 Single-Sided Gap Measurement

#### 6.1.1 Basic Settings



➡ Touch the Gap Measure (1-sided) button.

15.04.2019 11:12:03 64%

**Enter user settings**

**User:**

**Factory / Location:**

**File name (e.g. machine):**

**Temperature (°C):**

MD6-22

➡ Type a name in the User field.

➡ Enter an additional description for the user field in the Factory/Location field.

➡ Select a file name in the File name (e.g. machine)<sup>1</sup> field. This name is also used for the file name of the log.

➡ Type the current temperature in the Temperature (°C) field.

➡ Confirm your entry with .

1) File: <File name>\_yyyy-mm-dd\_hhmmss.csv  
 Folder: .\data\

### 6.1.2 Instant Measurement

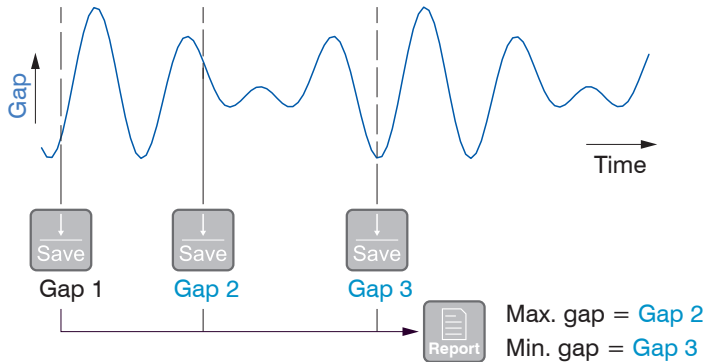

The Instant measurement program immediately saves the current measured value.

The Report function determines the smallest (Min. gap) and largest (Max. gap) gap width based on the derived values.

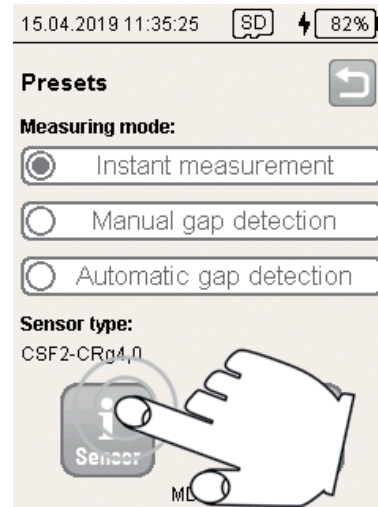

➡ Switch to the menu with the sensor settings.

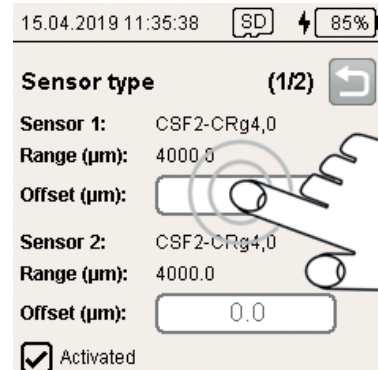

➡ Switch to the menu for setting the offset.

➡ Touch the Offset field.



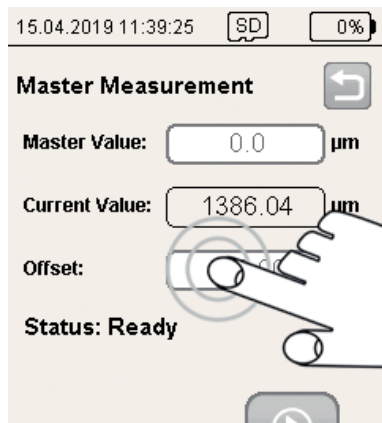



The program routine now switches to the Master Measurement menu.

➔ Enter the thickness of the sensor used in the Offset field.

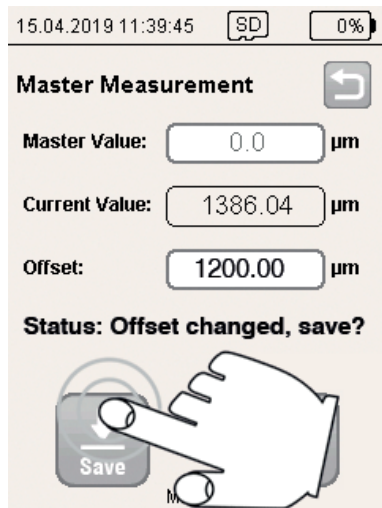
➔ Confirm your entry with .



➔ Save your entry with .

➔ Return to the Presets menu. To do so, touch  twice.

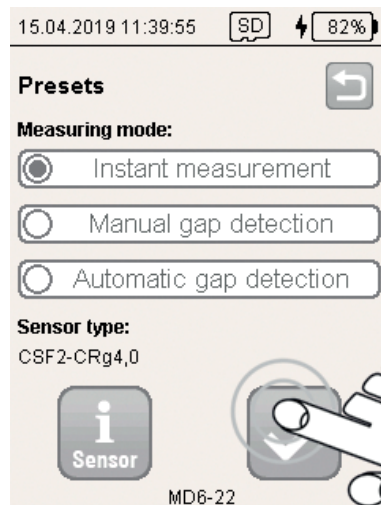

➔ Select the Instant Measurement program.

➔ Confirm the entry with .

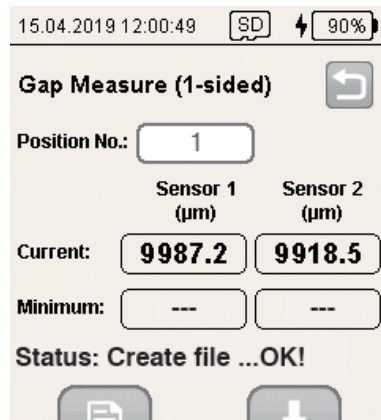

The controller starts the measurement.

➔ Insert the sensor into the gap.

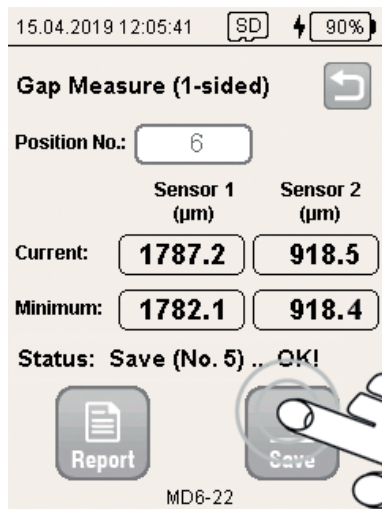
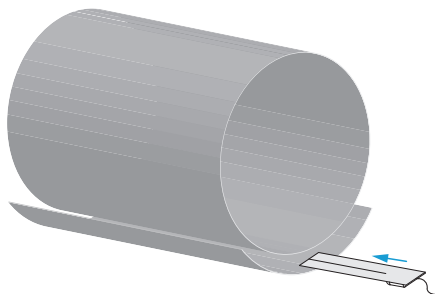

The controller measures the gap width and displays the values in the **Current** field.

➔ Touch  to save the current measured value.

Each touch of the **Save** button updates the value in the **Minimum** field and increases the counter in the **Position No.** field by one.

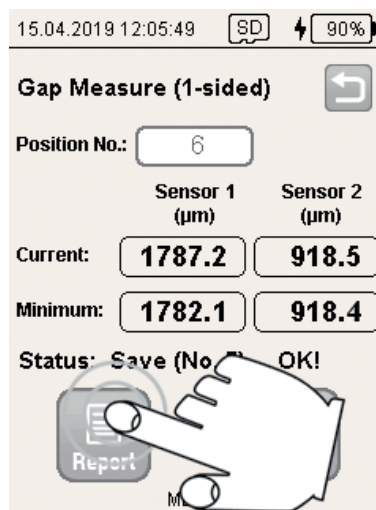

The **Report** function offers a statistical function for all measured values saved so far.

➔ Touch  to switch to the **Report** menu.



The report lists the smallest (**Min. gap**) and largest (**Max. gap**) gap width in a series of measurements for both sensors.

### 6.1.3 Manual Gap Detection

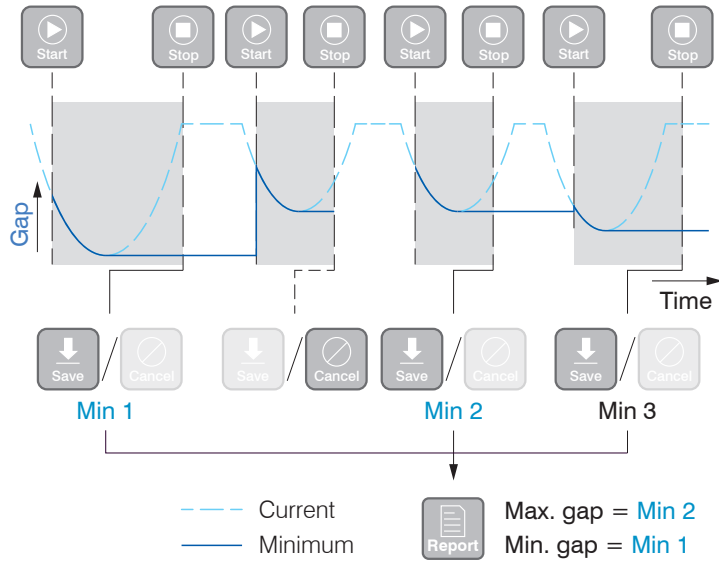

The Manual gap detection program determines the local minimum during an analysis period between Start and Stop. The Report function determines the smallest (Min. gap) and largest (Max. gap) gap width based on the derived values.

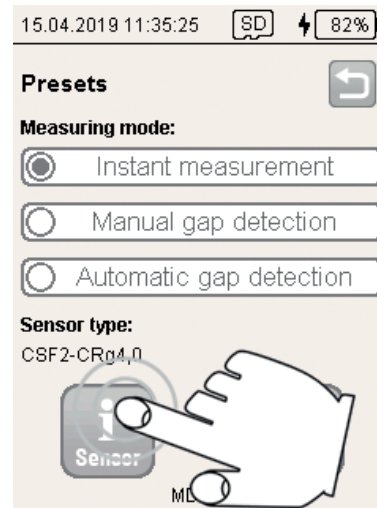

➔ Switch to the menu with the sensor settings.

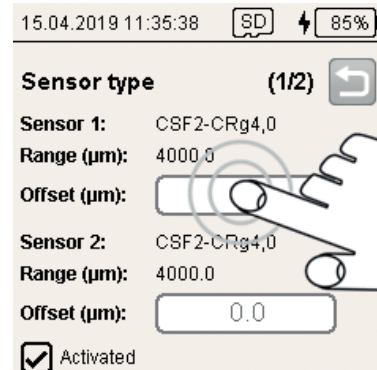

➔ Switch to the menu for setting the offset.

➔ Touch the Offset field.

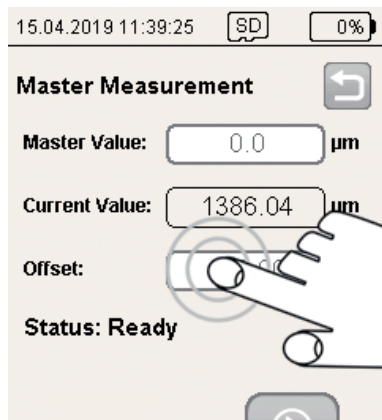



The program routine now switches to the Master Measurement menu.

➔ Enter the thickness of the sensor used in the Offset field.

➔ Confirm your entry with .

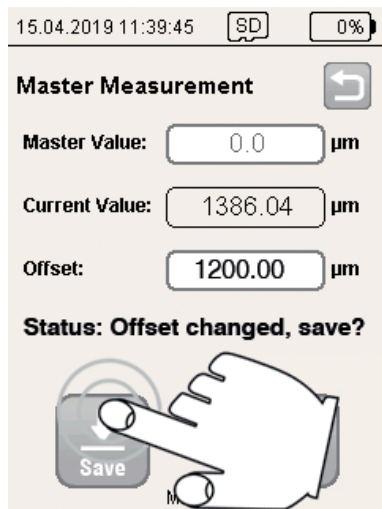
➔ Save your entry with .



➔ Return to the Presets menu. To do so, touch  twice.

MD6-22

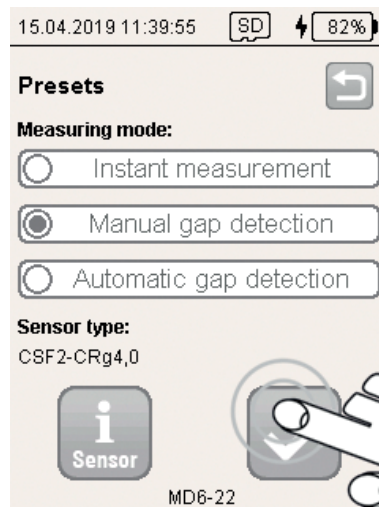

➔ Select the Manual gap detection program.

➔ Confirm the entry with .

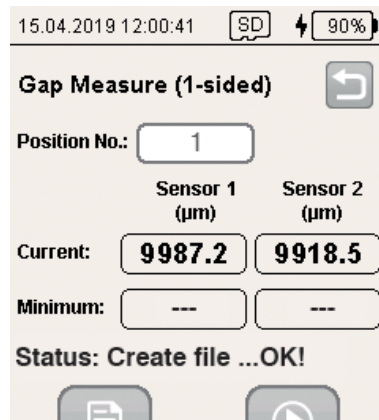

The controller starts the measurement.

➔ Insert the sensor into the gap.

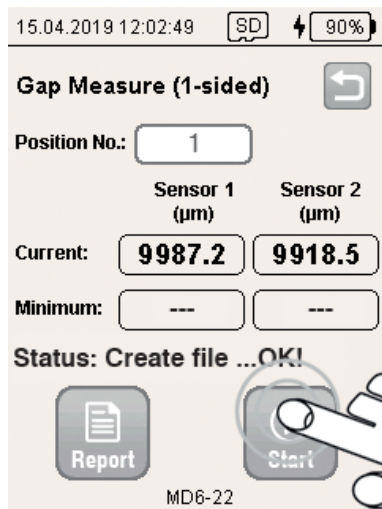
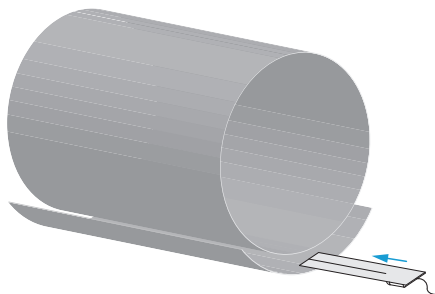

The controller measures the gap width and displays the values in the **Current** field.

➔ Touch to start the search for the minimum.

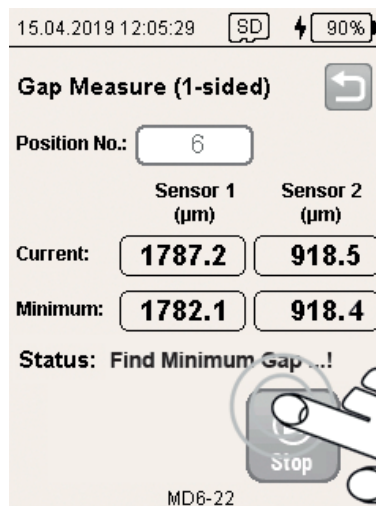

The minimum reached between **Start** and **Stop** is displayed in the **Minimum** field.

➔ Touch to interrupt a measurement.

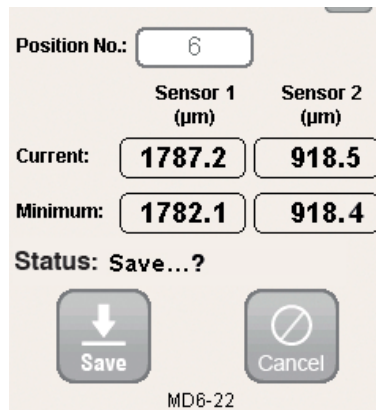

The detected minimum can subsequently be saved or discarded by touching the **Cancel** button.

Each touch of the **Save** button increases the counter in the **Position No.** field by one.

15.04.2019 12:05:49 SD 90%

**Gap Measure (1-sided)** ↶

Position No.:

	Sensor 1 ( $\mu\text{m}$ )	Sensor 2 ( $\mu\text{m}$ )
Current:	<b>1787.2</b>	<b>918.5</b>
Minimum:	<b>1782.1</b>	<b>918.4</b>

Status: Save (No) OK!

 Report

The Report function lists all minimum values saved so far.

➔ Touch  to switch to the Report menu.

15.04.2019 12:06:05 SD 92%

**Report** ↶

Sensor 1:  
 Max. gap( $\mu\text{m}$ )=1824.2 at Pos 5  
 Min. gap( $\mu\text{m}$ )=1751.5 at Pos 2  
 Difference( $\mu\text{m}$ )=72.7

Sensor 2:  
 Max. gap( $\mu\text{m}$ )=991.6 at Pos 2  
 Min. gap( $\mu\text{m}$ )=918.4 at Pos 6  
 Difference( $\mu\text{m}$ )=73.2

Filename:  
 EN123\_2019-04-15\_113459.csv

Status: **Ready!**

The report lists the smallest (Min. gap) and largest (Max. gap) gap width in a series of measurements for both sensors.

### 6.1.4 Automatic Gap Detection

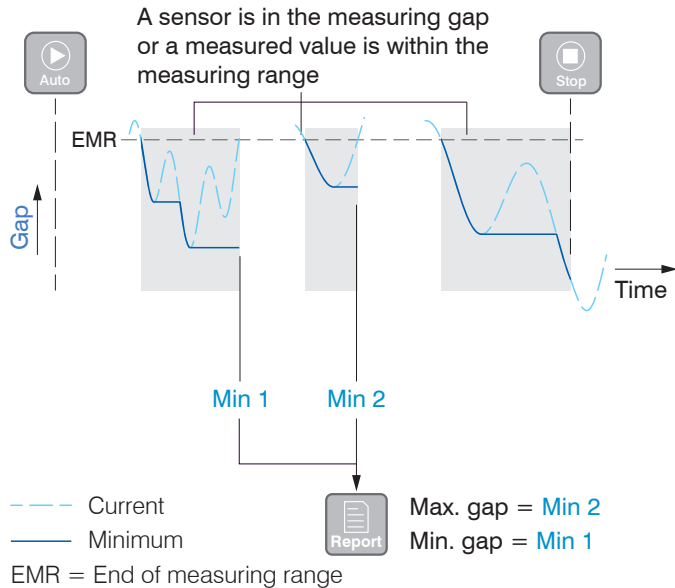

The Automatic gap detection program determines local minimums within a range between Auto and Stop if

- a sensor is in the measuring gap or
- a measured value is within the measuring range.

When you leave the measuring range, the current minimum is automatically saved.

The Report function determines the smallest (Min. gap) and largest (Max. gap) gap width based on the derived values.

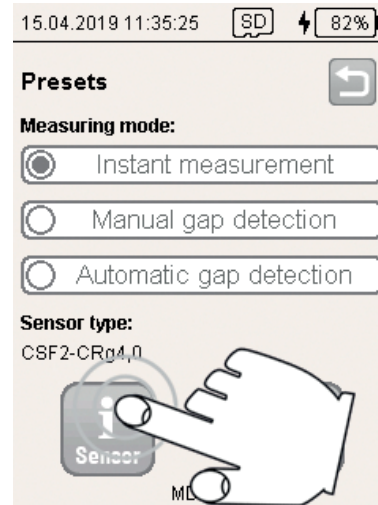

➡ Switch to the menu with the sensor settings.

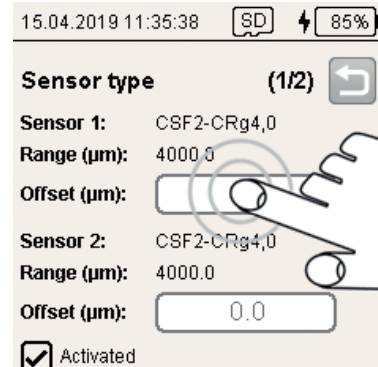

➡ Switch to the menu for setting the offset.

➡ Touch the Offset field.

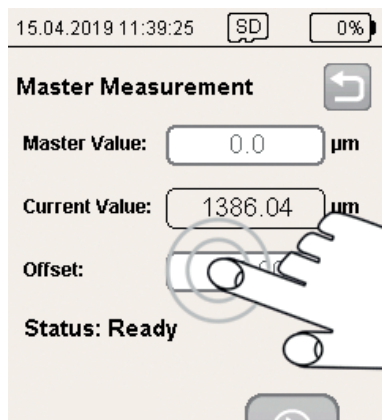



The program routine now switches to the Master Measurement menu.

➔ Enter the thickness of the sensor used in the Offset field.

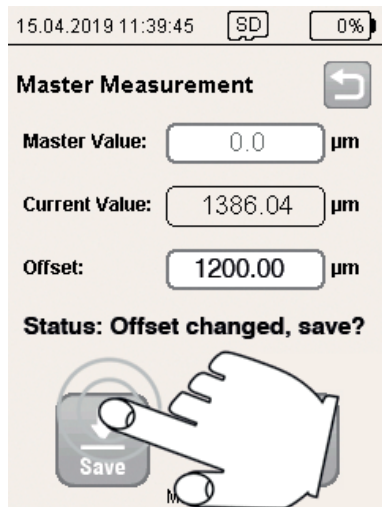
➔ Confirm your entry with .



➔ Save your entry with .

➔ Return to the Presets menu. To do so, touch  twice.

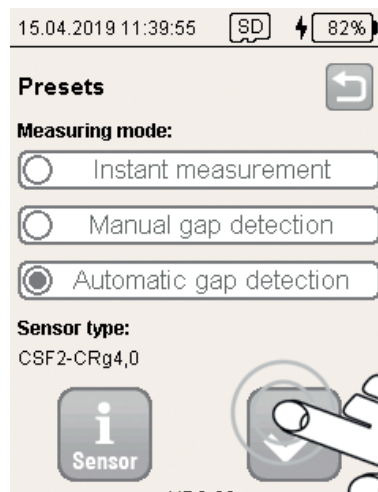

➔ Select the Automatic gap detection program.

➔ Confirm the entry with .

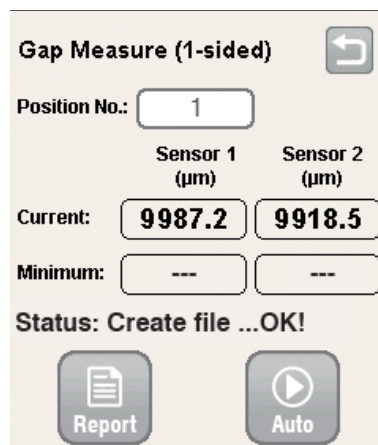

➔ Touch  to start the measurement.



➔ Insert the sensor into the gap.

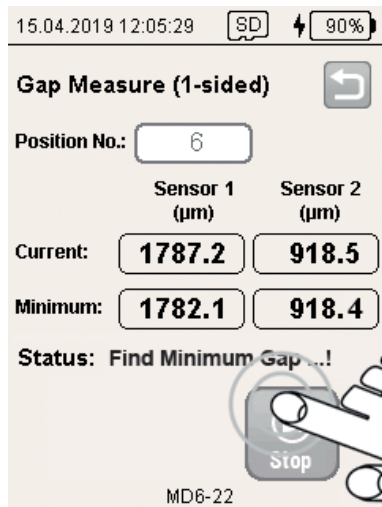
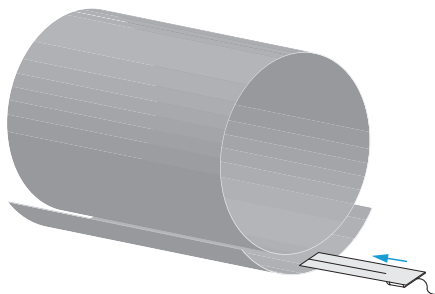

The controller measures the gap width and displays the values in the **Current** field.

The **Minimum** field displays the smallest gap width.

You start a measurement by removing the sensor from the measuring gap and re-inserting it in another location.

The counter in the **Position No.** field is increased by one when the measured value leaves the measuring range.

➔ Touch  to end the series of measurements.

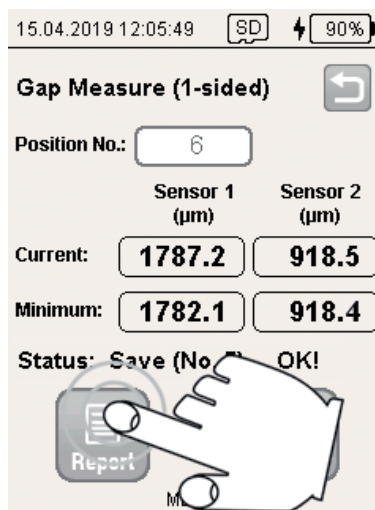

The Report function offers a statistical function for all minimum values saved so far.

➔ Touch  to switch to the Report menu.



The report lists the spread of minimum values for both sensors.

## 6.2 Double-Sided Gap Measurement (Minimum)

### 6.2.1 Basic Settings

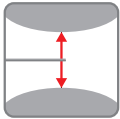

➔ Touch the **Gap Measure (2-sided, Min)** button.

15.04.2019 11:12:03 SD 64%

**Enter user settings** ↶

**User:**

**Factory / Location:**

**File name (e.g. machine):**

**Temperature (°C):**  
 ✓

MD6-22

➔ Type a name in the **User** field.

➔ Enter an additional description for the user field in the **Factory/Location** field.

➔ Select a file name in the **File name (e.g. machine)**<sup>1</sup> field. This name is also used for the file name of the log.

➔ Type the current temperature in the **Temperature (°C)** field.

➔ Confirm your entry with ✓.

1) File: <File name>\_yyyy-mm-dd\_hhmmss.csv  
 Folder: .\data\<<Datum(yyyy-mm-dd)>\gap\_2sided\

### 6.2.2 Instant Measurement

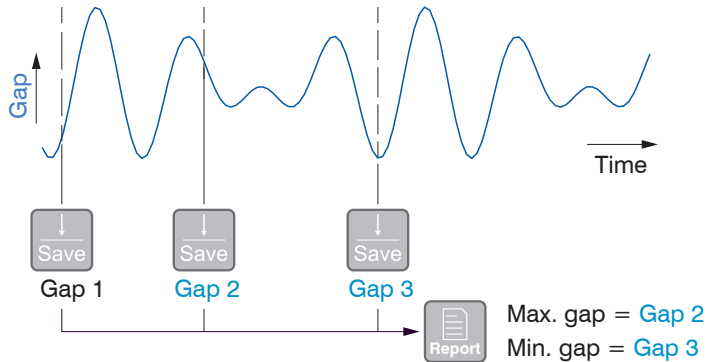

The Instant measurement program immediately saves the current measured value.

The Report function determines the smallest (Min. gap) and largest (Max. gap) gap width based on the derived values.

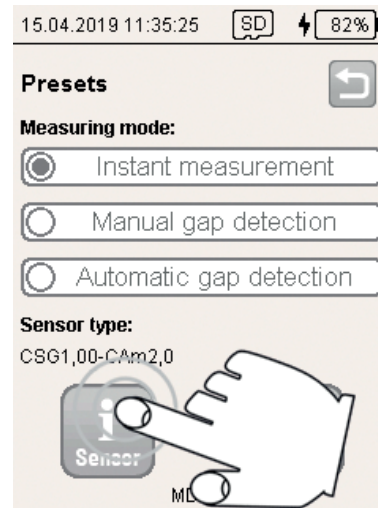

➡ Switch to the menu with the sensor settings.

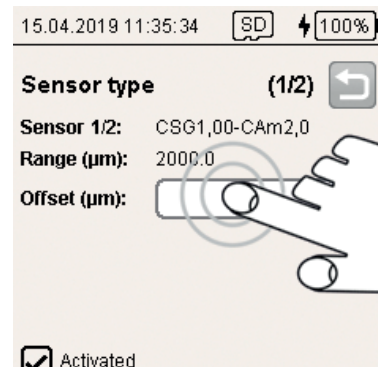

➡ Switch to the menu for setting the offset.

➡ Touch the Offset field.

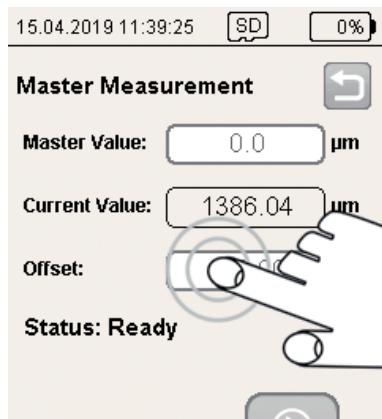



The program routine now switches to the Master Measurement menu.

➔ Enter the thickness of the sensor used in the Offset field.

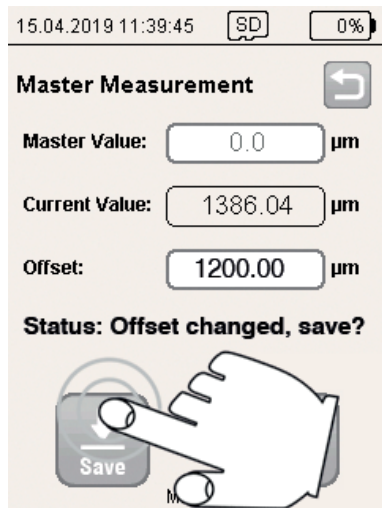
➔ Confirm your entry with .



➔ Save your entry with .

➔ Return to the Presets menu. To do so, touch  twice.

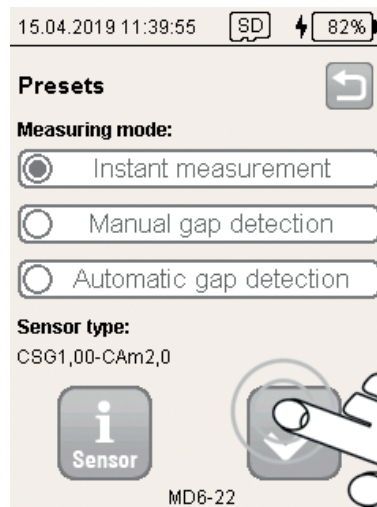

➔ Select the Instant Measurement program.

➔ Confirm the entry with .

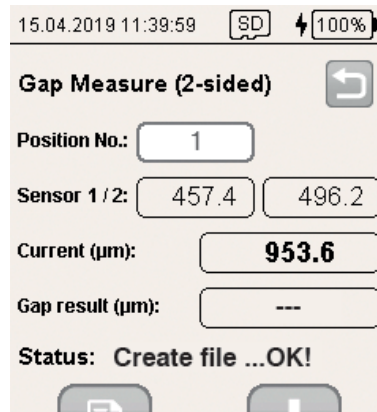

The controller starts the measurement.

➔ Insert the sensor into the gap.

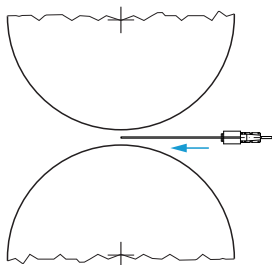

15.04.2019 11:49:05 [SD] [100%]

**Gap Measure (2-sided)** ↻

Position No.:

Sensor 1 / 2:

Current (µm):

Gap result (µm):

Status: Save (No. 6) OK!

MD6-22

The controller measures the gap width and displays the values in the **Current** field.

➔ Touch to save the current measured value.

Each touch of the **Save** button updates the value in the **Gap Result** field and increases the counter in the **Position No.** field by one.

15.04.2019 12:05:49 [SD] [100%]

**Gap Measure (2-sided)** ↻

Position No.:

Sensor 1 / 2:

Current (µm):

Gap result (µm):

Status: Save (No. 7) OK!

The **Report** function offers a statistical function for all measured values saved so far.

➔ Touch to switch to the **Report** menu.

15.04.2019 12:06:05 [SD] [92%]

**Report** ↻

Sensor 1:  
 Max. gap(µm)=1824.2 at Pos 5  
 Min. gap(µm)=1751.5 at Pos 2  
 Difference(µm)=72.7

Sensor 2:  
 Max. gap(µm)=991.6 at Pos 2  
 Min. gap(µm)=918.4 at Pos 6  
 Difference(µm)=73.2

Filename:  
 EN123\_2019-04-15\_113459.csv

Status: Ready!

The report lists the smallest (Min. gap) and largest (Max. gap) gap width in a series of measurements for the sensor.

### 6.2.3 Manual Gap Detection

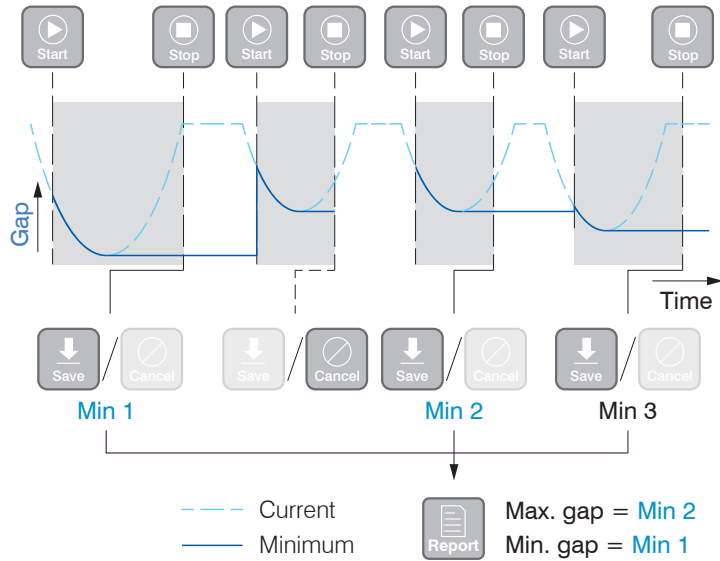

The Manual gap detection program determines the local minimum during an analysis period between Start and Stop. The Report function determines the smallest (Min. gap) and largest (Max. gap) gap width based on the derived values.

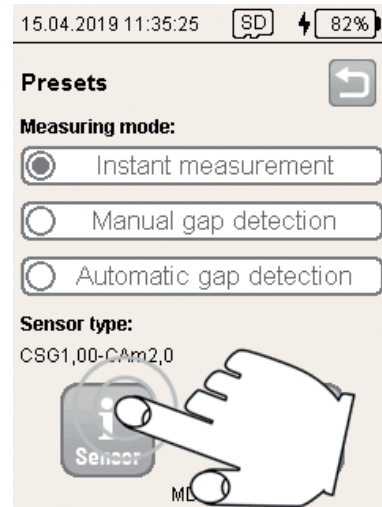

➔ Switch to the menu with the sensor settings.

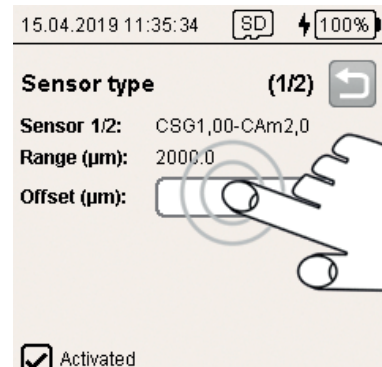

➔ Switch to the menu for setting the offset.

➔ Touch the Offset field.

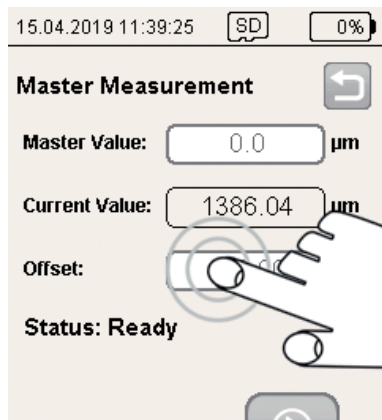



The program routine now switches to the **Master Measurement** menu.

➔ Enter the thickness of the sensor used in the **Offset** field.

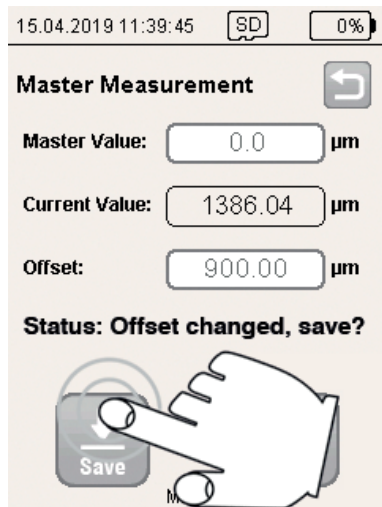
➔ Confirm your entry with .



➔ Save your entry with .

➔ Return to the **Presets** menu. To do so, touch  twice.

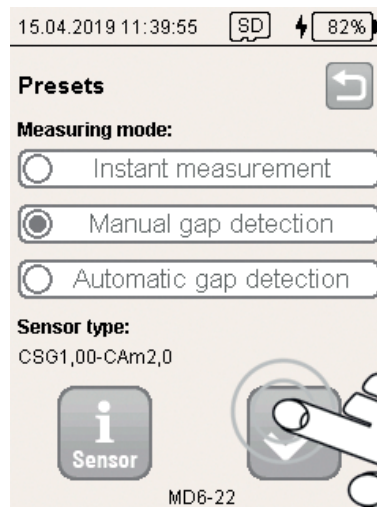

➔ Select the **Manual gap detection** program.

➔ Confirm the entry with .

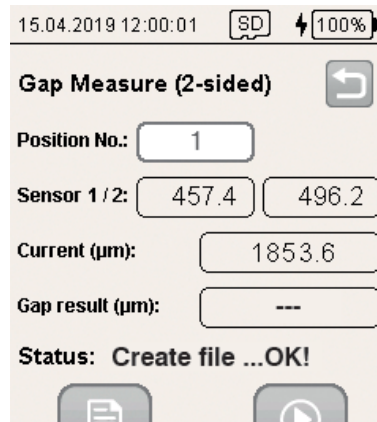

The controller starts the measurement.

➔ Insert the sensor into the gap.

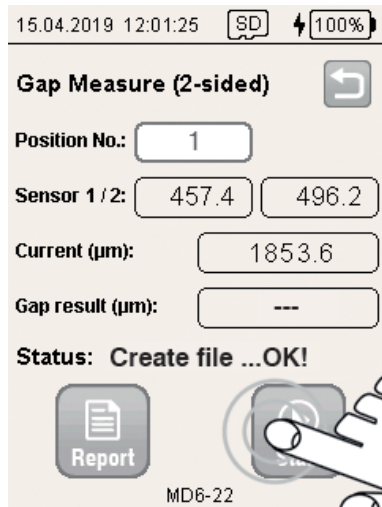
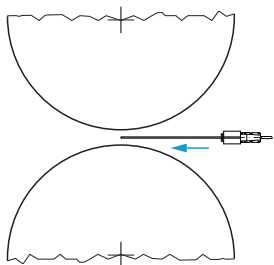

The controller measures the gap width and displays the values in the **Current** field.

➔ Touch  to start the search for the minimum.

The **Gap result** field shows the smallest gap width.

The **Position No.** field displays the values that have been recorded so far.

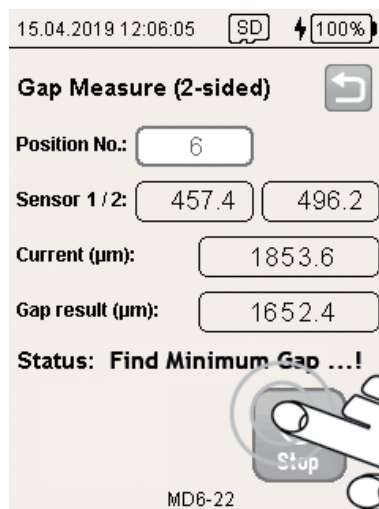

The minimum reached between **Start** and **Stop** is displayed in the **Gap result** field.

➔ Touch  to interrupt the search for the minimum.

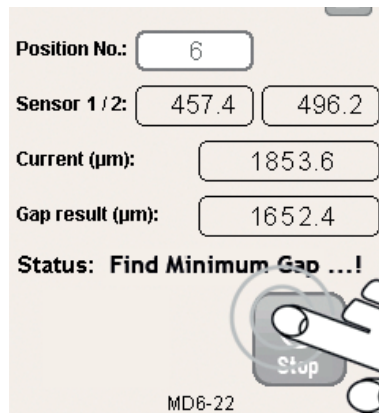

The detected minimum can subsequently be saved with the **Save** button or discarded by touching the **Cancel** button.

Each touch of the **Save** button increases the counter in the **Position No.** field by one.



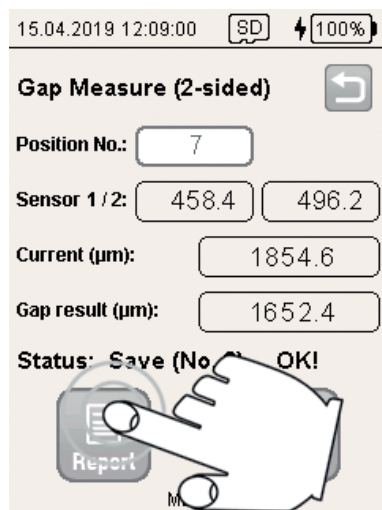

The Report function offers a statistical function for all minimum values saved so far.

➔ Touch  to switch to the Report menu.



The report lists the spread of minimum values for the sensor.

### 6.2.4 Automatic Gap Detection

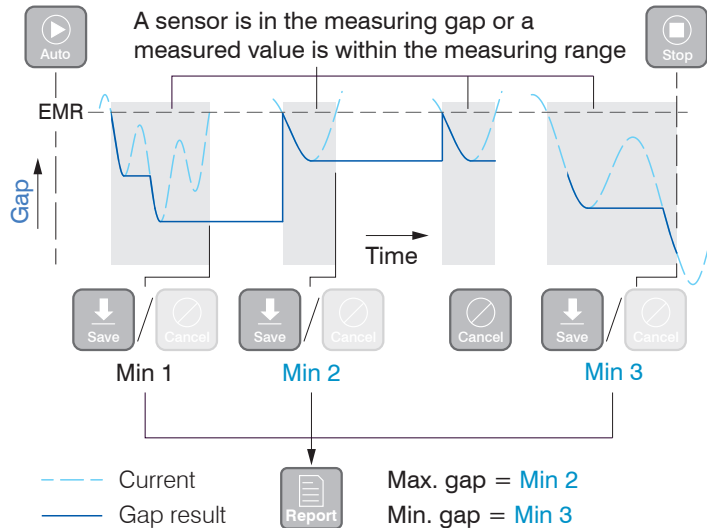

The Automatic gap detection program determines local minimums during an analysis period if a sensor is in the measuring gap. An analysis period

- is started with the Auto function,
- and stopped early with Stop.

A minimum found must be saved with the Save function or discarded with the Cancel function.

The Report function determines the smallest (Min. gap) and largest (Max. gap) gap width based on the derived values.

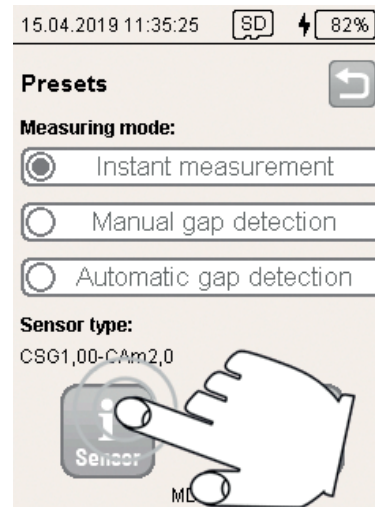

➔ Switch to the menu with the sensor settings.

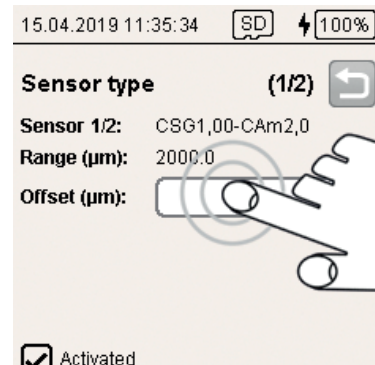

➔ Switch to the menu for setting the offset.

➔ Touch the Offset field.

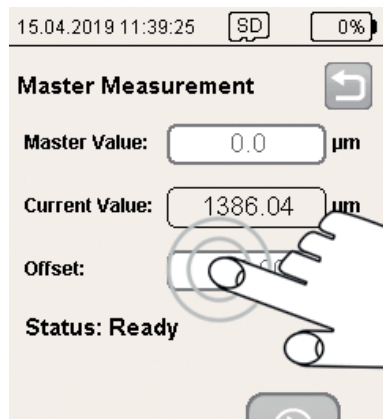



The program routine now switches to the Master Measurement menu.

➔ Enter the thickness of the sensor used in the Offset field.

➔ Confirm your entry with .

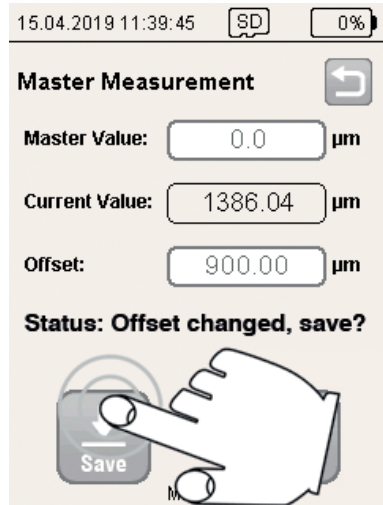
➔ Save your entry with .



➔ Return to the Presets menu. To do so, touch  twice.

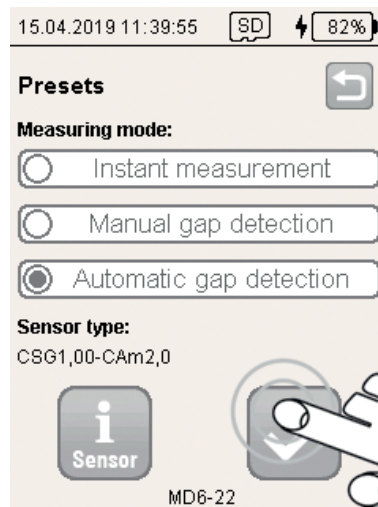

➔ Select the Automatic gap detection program.

➔ Confirm the entry with .

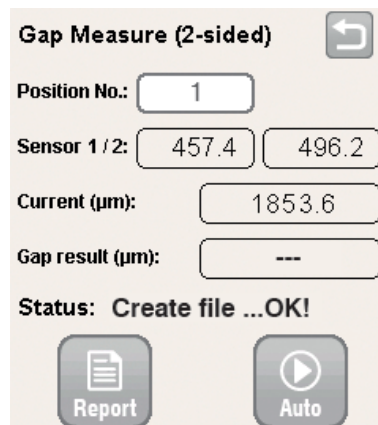

The controller starts the measurement.

➔ Insert the sensor into the gap.

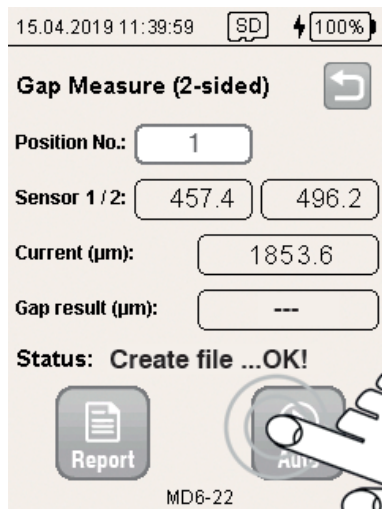
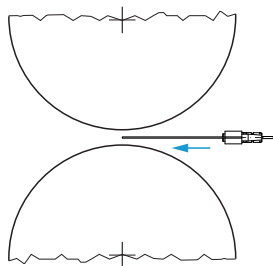

The controller measures the gap width and displays the values in the **Current** field.

➔ Touch  to start the search for a minimum with automatic start-stop.

The search starts when both sensors' measured values become smaller than the end of the measuring range (offset and measuring range).

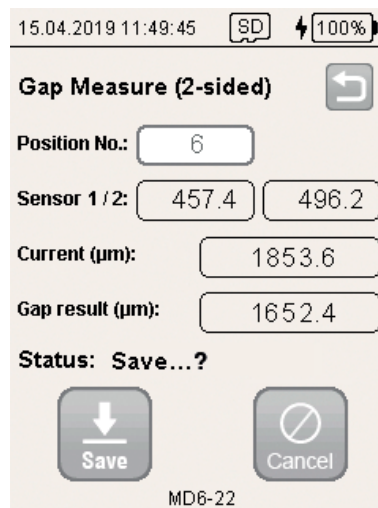

The measurement is stopped automatically, if one measured value of both sensors becomes 1% larger than the end of the measuring range.

The detected minimum can subsequently be saved or discarded by touching the **Cancel** button.

Each touch of the **Save** button increases the counter in the **Position No.** field by one.

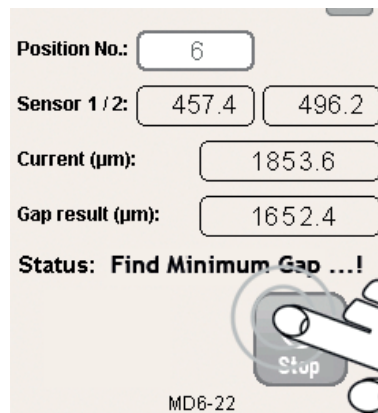

➔ Touch  to interrupt a measurement.

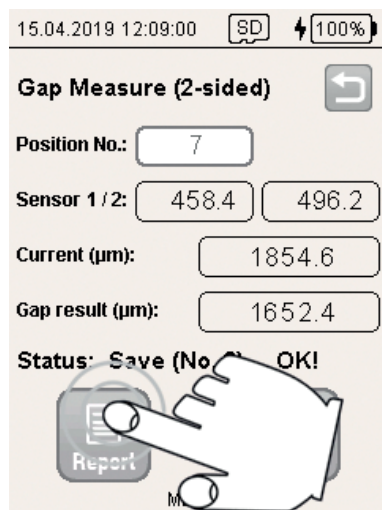

The `Gap result` field displays the smallest gap width.

The `Report` function offers a statistical function for all minimum values saved so far.

➡ Touch  to switch to the `Report` menu.



The report lists the spread of minimum values for the sensor.

## 6.3 Double-Sided Gap Measurement (Maximum)

### 6.3.1 General

The search for the maximum is suitable for finding a straight alignment of the sensor in the measuring gap.

### 6.3.2 Basic Settings

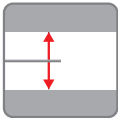

➡ Touch the **Gap Measure (2-sided, Max)** button.

15.04.2019 11:12:03 64%

**Enter user settings**

**User:**

**Factory / Location:**

**File name (e.g. machine):**

**Temperature (°C):**

MD6-22

➡ Type a name in the **User** field.

➡ Enter an additional description for the user field in the **Factory/Location** field.

➡ Select a file name in the **File name (e.g. machine)**<sup>1</sup> field. This name is also used for the file name of the log.

➡ Type the current temperature in the **Temperature (°C)** field.

➡ Confirm your entry with .

1) File: <File name>\_yyyy-mm-dd\_hhmmss.csv  
 Folder: .\data\<Date(yyyy-mm-dd)>\gap\_2sided\

### 6.3.3 Instant Measurement

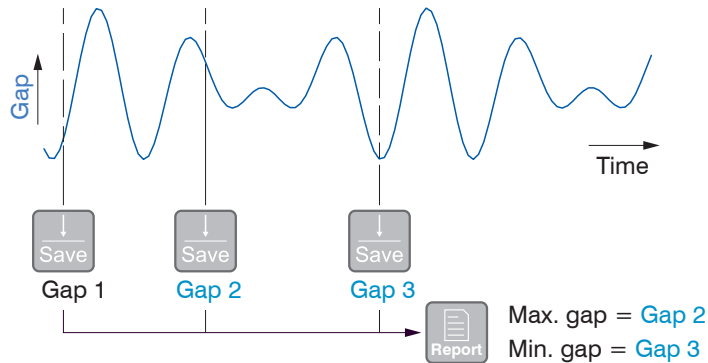

The Instant measurement program saves measured values. The Report function determines the smallest (Min. gap) and largest (Max. gap) gap width based on the derived values.

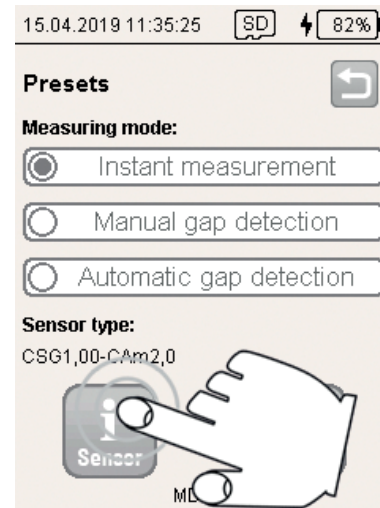

➡ Switch to the menu with the sensor settings.

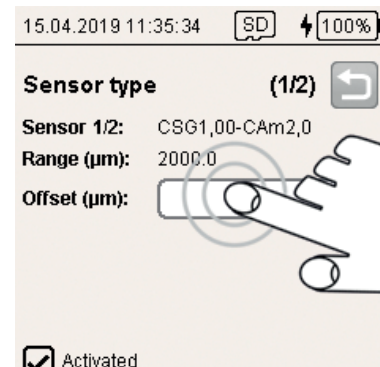

➡ Switch to the menu for setting the offset.

➡ Touch the Offset field.

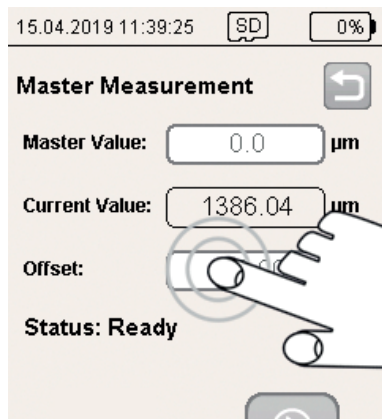

The program routine now switches to the Master Measurement menu.  
 ➔ Enter the thickness of the sensor used in the Offset field.

➔ Confirm your entry with .

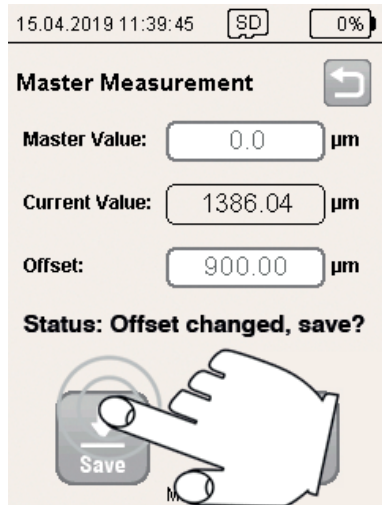

➔ Save your entry with .

➔ Return to the Presets menu. To do so, touch  twice.

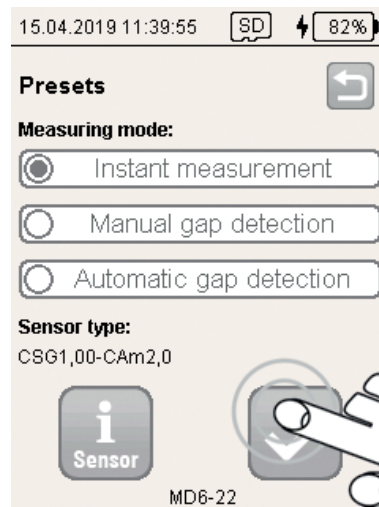

➔ Select the Instant Measurement program.

➔ Confirm the entry with .

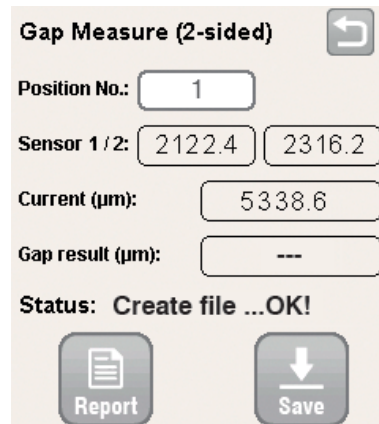

The controller starts the measurement.



➔ Insert the sensor into the gap.

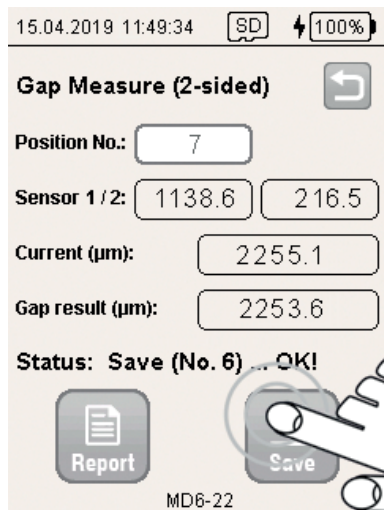
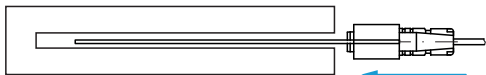

The controller measures the gap width and displays the values in the **Current** field.

➔ Touch  to save the current value.

Each additional touch of the **Save** button updates the value in the **Gap result** field and increases the counter in the **Position No.** field by one.

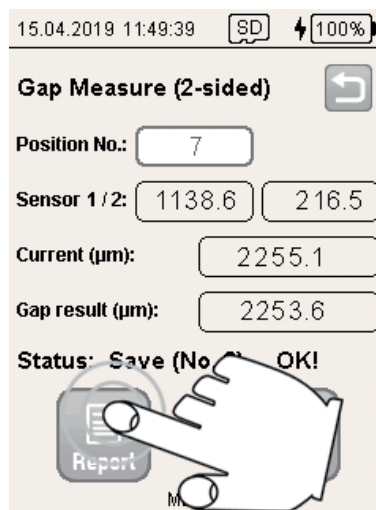

The **Report** function lists all measured values saved so far.

➔ Touch  to switch to the **Report** menu.



The report lists the minimum and maximum values in a series of measurements for both sensors.

### 6.3.4 Manual Gap Detection

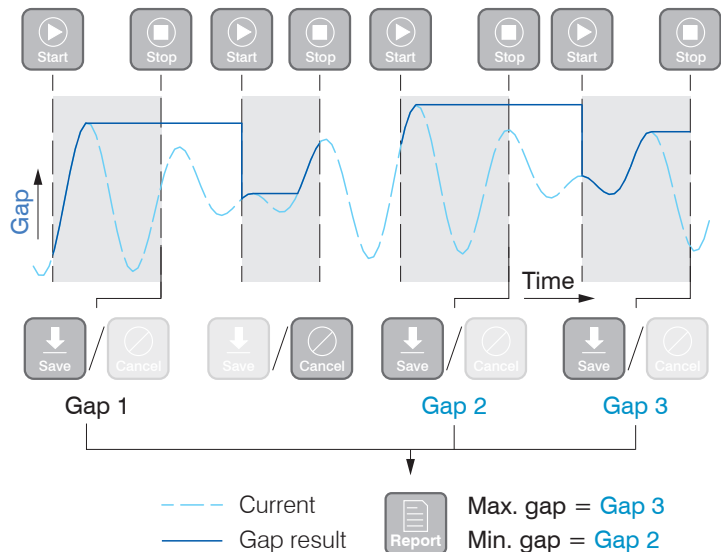

The Manual gap detection program determines the local maximum during an analysis period between Start and Stop.<sup>1</sup> The Report function determines the smallest (Min. gap) and largest (Max. gap) gap width based on the derived values.

1) During Start, the sensor is located in the measuring gap.

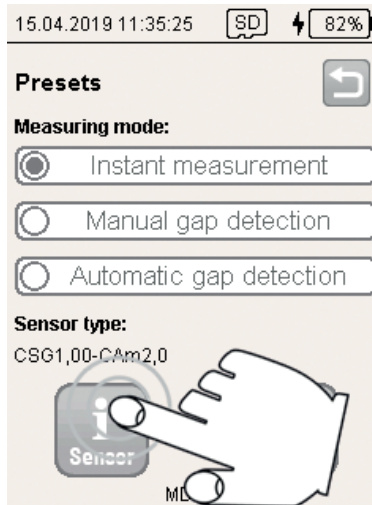

➔ Switch to the menu with the sensor settings.

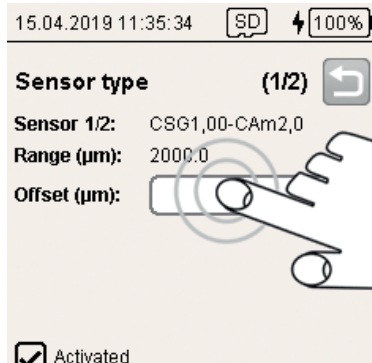

➔ Switch to the menu for setting the offset.

➔ Touch the Offset field.

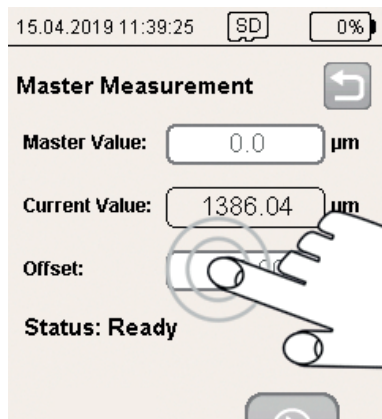



The program routine now switches to the Master Measurement menu.

➔ Enter the thickness of the sensor used in the Offset field.

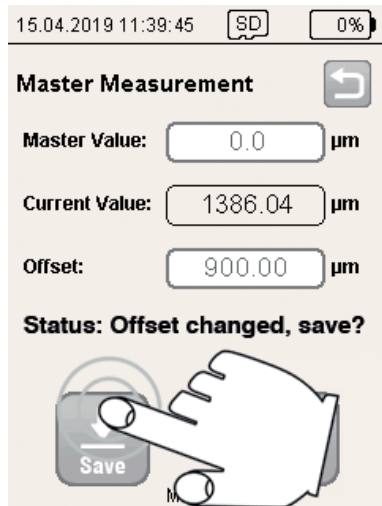
➔ Confirm your entry with .



➔ Save your entry with .

➔ Return to the Presets menu. To do so, touch  twice.

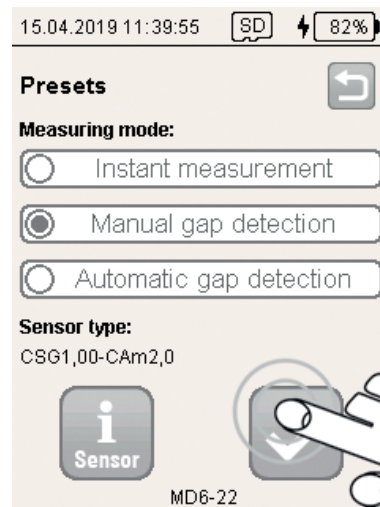

➔ Select the Manual gap detection program.

➔ Confirm the entry with .

➔ Insert the sensor into the gap.



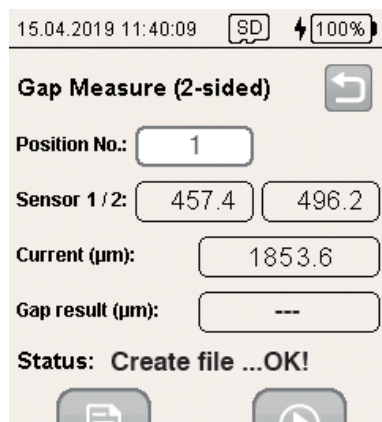

The controller starts the measurement.

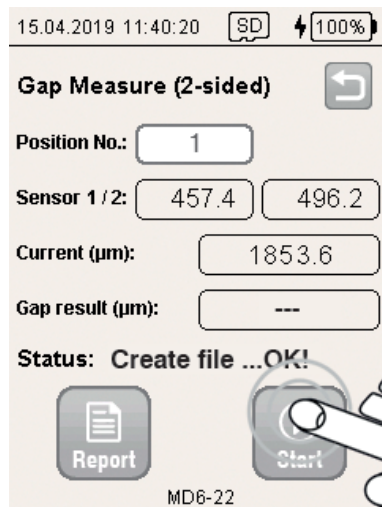

The controller measures the gap width and displays the value in the **Current** field.

➔ Touch  to identify the maximum in the current series of measurements.

The calculated gap is valid and can be used only when both sensors' measured values are smaller than the end of the measuring range.

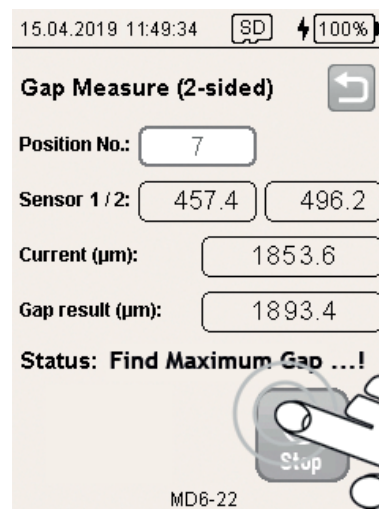

➔ Touch  to end the search.

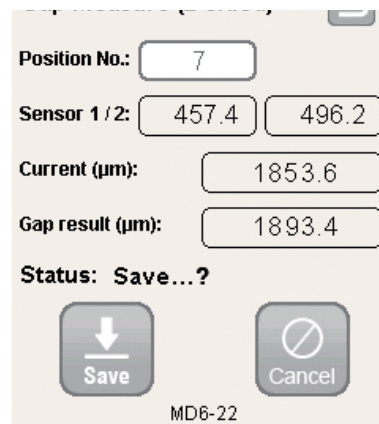

The maximum found can now be saved or discarded by touching the **Cancel** button.

Each touch of the **Save** button increases the counter in the **Position No.** field by one.

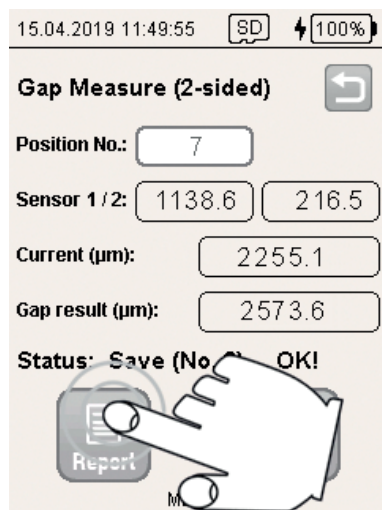

The Report function offers a statistical function for all minimum values saved so far.

➡ Touch  to switch to the Report menu.



The report lists the spread of maximum values for the sensor.

### 6.3.5 Automatic Gap Detection

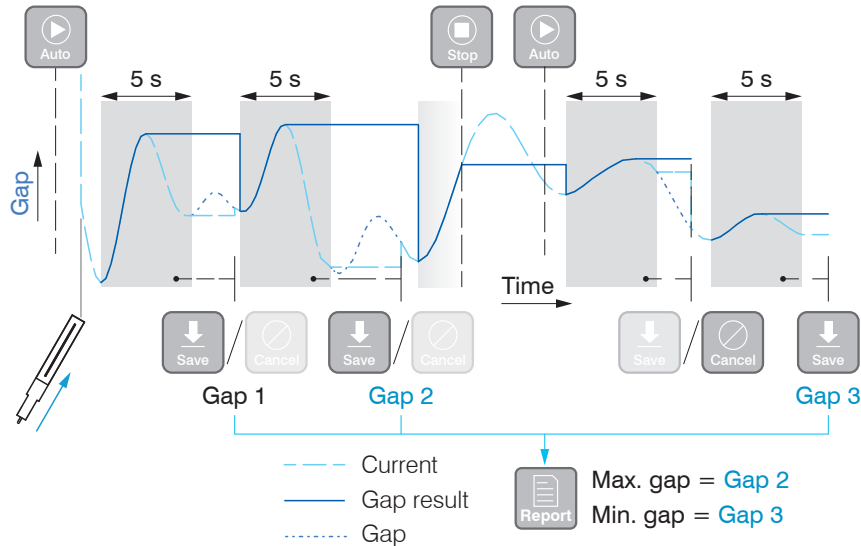

The Automatic gap detection program helps to perfectly align the sensor and determines local maximums during an analysis period.

An analysis period is started, if

- the Auto function has been selected and
- a sensor is in the measuring gap or
- the previous measured value has been saved with the Save function.

An analysis period can be stopped early with the Stop function; the measured value is discarded.

An analysis period starts when a local minimum was detected and is limited to a period of at most 5 seconds. The program detects insertion of the sensor into the measuring gap.

The Report function determines the smallest (Min. gap) and largest (Max. gap) gap width based on the derived values.

Notes about a measurement

- Swiftly insert the sensor into the gap.
- Tilt the sensor in the measuring gap.

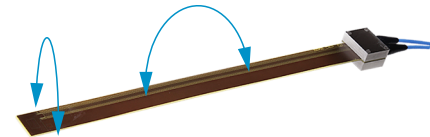

➡ Switch to the menu with the sensor settings.

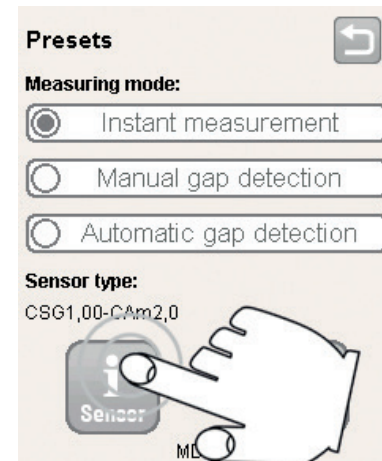

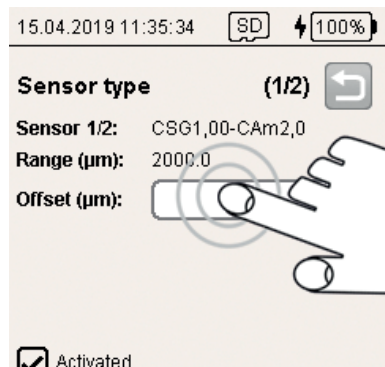

➔ Switch to the menu for setting the offset.

➔ Touch the *Offset* field.

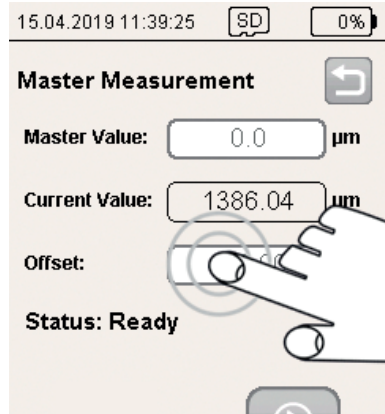



The program routine now switches to the *Master Measurement* menu.

➔ Enter the thickness of the sensor used in the *Offset* field.

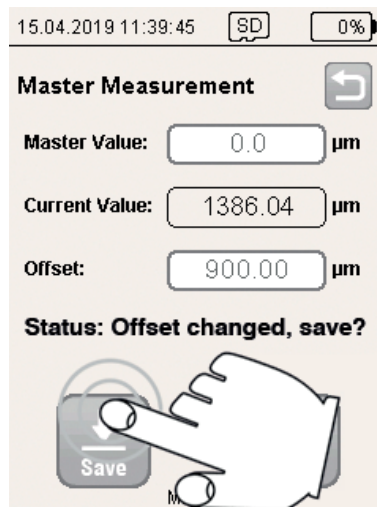
➔ Confirm your entry with .



➔ Save your entry with .

➔ Return to the *Presets* menu. To do so, touch  twice.

15.04.2019 11:39:55 SD 82%

**Presets** ↶

**Measuring mode:**

Instant measurement

Manual gap detection

Automatic gap detection

**Sensor type:**  
CSG1,00-CAM2,0

i Sensor MD6-22

**Gap Measure (2-sided)** ↶

**Position No.:**

**Sensor 1 / 2:**

**Current (µm):**

**Gap result (µm):**

**Status: Create file ...OK!**

Report Auto

➔ Select the Automatic gap detection program.

➔ Confirm the entry with .

➔ Touch  to start automatic measurement.

The controller automatically detects insertion of the sensor into the measuring gap and waits until that point to start the measurement.

➔ Insert the sensor into the gap.

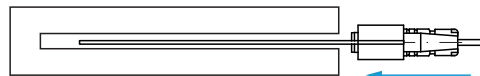

15.04.2019 11:41:04 SD 100%

**Gap Measure (2-sided)** ↶

**Position No.:**

**Sensor 1 / 2:**

**Current (µm):**

**Gap result (µm):**

**Status: Wait (2 s)**

Stop MD6-22

If the program finds a local minimum, it starts to search for a maximum within a period of 5 s.

When the Stop button is touched,

- automatic measurement is interrupted,
- the current maximum value (Gap result) is discarded.



**Gap Measure (2-sided)** 



Position No.:

Sensor 1 / 2:

Current ( $\mu\text{m}$ ):

Gap result ( $\mu\text{m}$ ):

Status: Save...?

MD6-22

The detected minimum can now be saved or discarded by touching the Cancel button.

Each touch of the Save button increases the counter in the Position No. field by one.

**Gap Measure (2-sided)** 

Position No.:

Sensor 1 / 2:

Current ( $\mu\text{m}$ ):

Gap result ( $\mu\text{m}$ ):

Status: Save (No) OK!

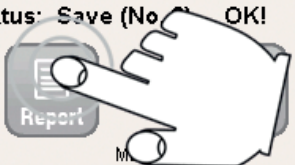

MD6-22

➡ Touch  to end a series of measurements.

The Report function offers a statistical function for all maximum values saved so far.

➡ Touch  to switch to the Report menu.

15.04.2019 12:06:05  

**Report** 

Sensor 1/2:  
 Max. gap( $\mu\text{m}$ )=3953.6 at Pos 5  
 Min. gap( $\mu\text{m}$ )=1234.4 at Pos 2  
 Difference( $\mu\text{m}$ )= 21719.2

Filename:  
 EN123\_2019-04-15\_130742.csv

**Status: Ready!**



MD6-22

The report lists the spread of maximum values for the sensor.

## 6.4 Single-value measurement with math function

### 6.4.1 Basic Settings

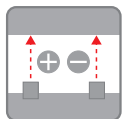

➔ Touch the **Raw Data Measure** button.

15.04.2019 11:12:03 SD 64%

**Enter user settings** 

**User:**

**Factory / Location:**

**File name (e.g. machine):**

**Temperature (°C):**  
 

MD6-22

- ➔ Type a name in the **User** field.
- ➔ Enter an additional description for the user field in the **Factory/Location** field.
- ➔ Select a file name in the **File name (e.g. machine)**<sup>1</sup> field. This name is also used for the file name of the log.
- ➔ Type the current temperature in the **Temperature (°C)** field.
- ➔ Confirm your entry with .

1) File: <File name>\_yyyy-mm-dd\_hhmmss.csv

Folder: .\data\<Date (yyyy-mm-dd)\>\raw:data\

### 6.4.2 Calculation

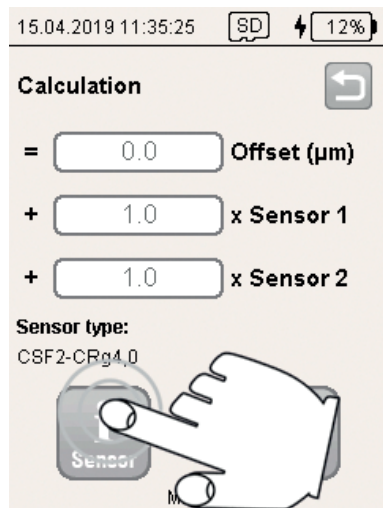

➔ Switch to the menu with the sensor settings.

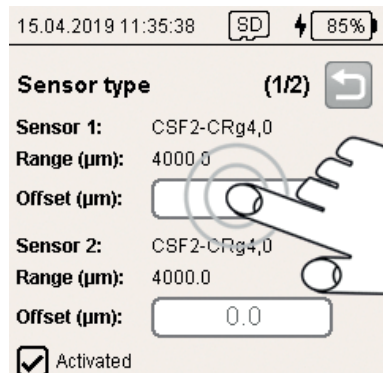

➔ Switch to the menu for setting the offset.

➔ Touch the Offset field.

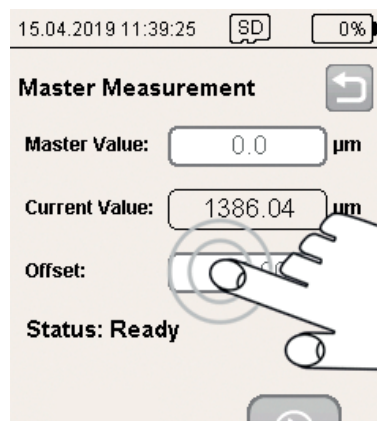

The program routine now switches to the Master Measurement menu.

➔ Touch the Offset field.

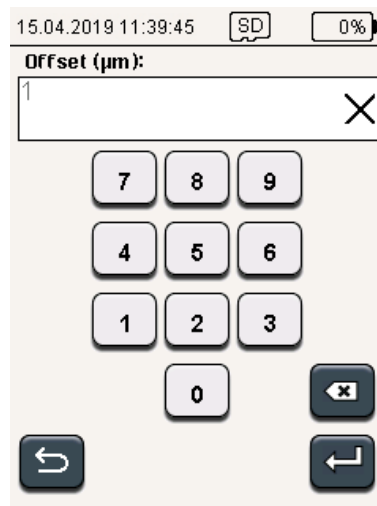

➔ Enter the thickness of the sensor used in the Offset field.

➔ Confirm your entry with

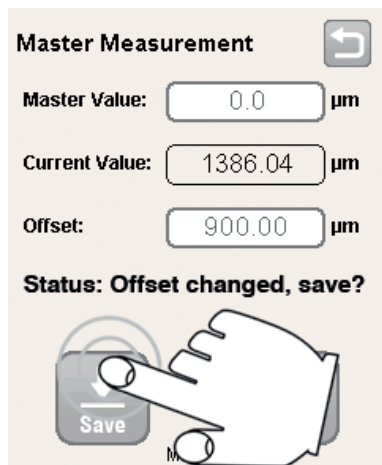

➔ Save your entry with .

➔ Return to the Calculation menu.  
To do so, touch  once.

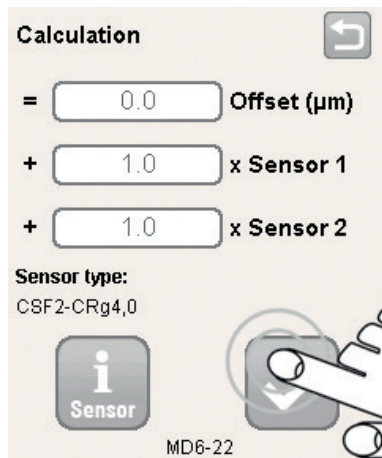

The two sensor signals can be calculated at will using a mathematical function.

Result = Offset + Factor x Sensor 1 + Factor x Sensor 2

➔ Confirm your entry with .

The program switches to the measurement view.

### 6.4.3 Single-value measurement with math function

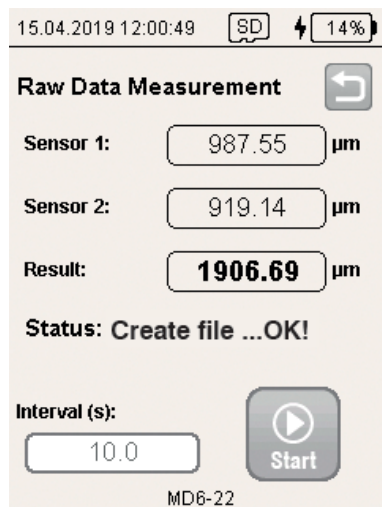

The controller starts the measurement.

The analysis period can be specified in the Interval (1 ... 3600 s) field.

➡ Insert the sensor into the gap.

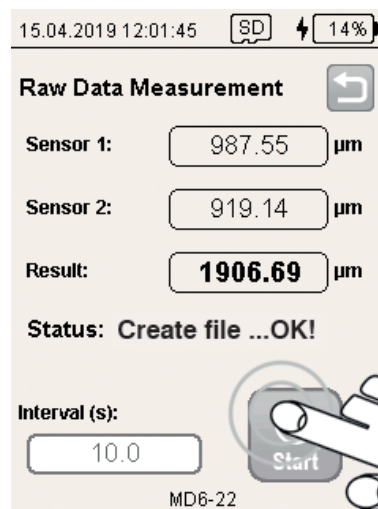
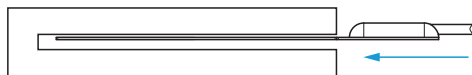

➡ Touch  to start the measurement.

The signals from both measuring channels and the result of the mathematical function are displayed. At the end of an interval, the current values are saved in a log.

➡ Touch  to end the measurement.

## 6.5 Device Information, Date and Time



➔ Touch the MICRO-EPSILON button.

15.04.2019 11:06:02 SD 100%

**Device Info** (1/2)

**Name:** MD6-22  
**Serial No.:** 904  
**Firmware:** V1.1e\_build297  
**Display SW:** V1.1e

Micro-Epsilon Messtechnik GmbH & Co.KG  
 www.micro-epsilon.com

**SD-Card Info**

2.0 MB used  
 1881.8 MB total



MD6-22

This menu view provides information about general device and SD card data.

**Set date / time** (2/2)

(dd.mm.yyyy) 15 . 4 . 20 19

(hh:mm:ss) 15 : 1 : 0



➔ Switch to the menu with the settings for date and time to manually set the internal clock.

1

7 8 9

4 5 6

1 2 3

0

➔ Touch the field that is to be changed and enter the corresponding information.

➔ Confirm the entry with .

**Set date / time** (2/2)

(dd.mm.yyyy) 15 . 4 . 20 19

(hh:mm:ss) 15 : 1 : 0



➔ Touch  to save the entries for date and time in the controller.

**i** If the battery is removed, the supply for the clock is buffered by the internal battery for a period of about two weeks.

## 6.6 Measurement with Reference Gap

If measurements are performed at different temperatures, inaccurate measurements due to thermal expansion of the sensor (thickness) may occur. By using a reference gap with known gap width that is thermally stable, you can have the controller compensate for the influence of temperature.

The following programs offer this option for compensation:

- Gap Measure (1-sided),
- Gap Measure (2-sided) Min,
- Gap Measure (2-sided) Max.

Proceed as follows:

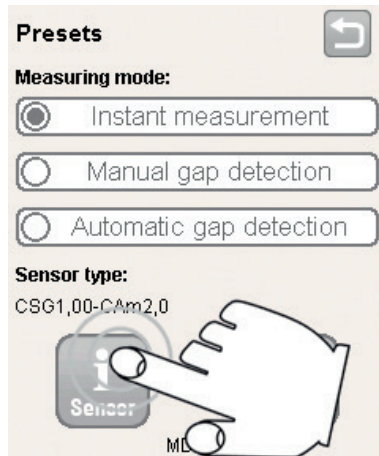

➡ Switch to the menu with the sensor settings.

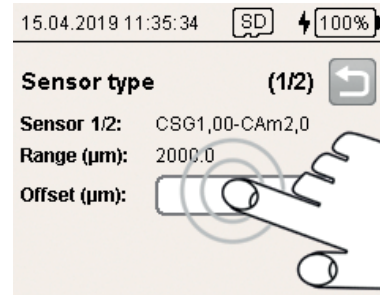

➡ Switch to the menu for setting the offset.

➡ Touch the Offset field.

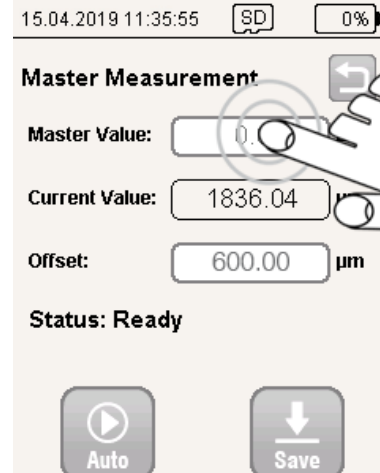

The program routine now switches to the Master Measurement menu.

➡ Enter the gap width of the reference gap in the Master Value field.

➡ Confirm your entry with .

➡ Insert the sensor into the gap.

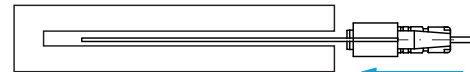

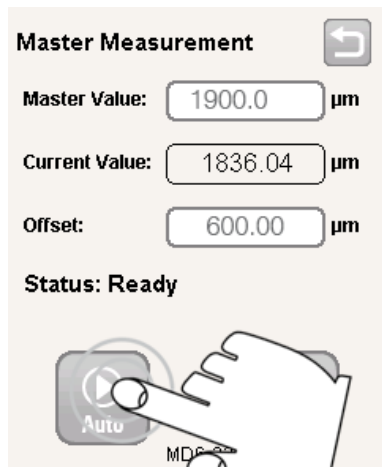

➔ Touch the  field.

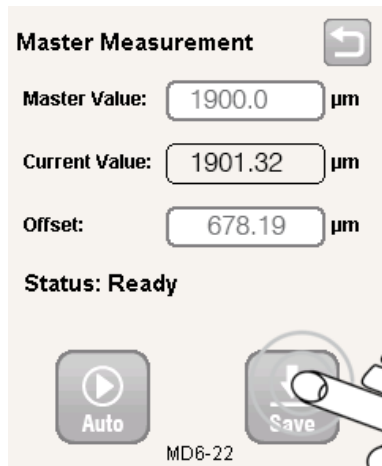

The controller calculates the actual thickness of the sensor based on the distance values and the value of the reference gap width, and displays this thickness in the *Offset* field.

➔ Save the new value of the offset with .

➔ Return to the *Presets* menu. To do so, touch  twice.

➔ Select the desired program and start the measurement.



## 6.7 Relative Measurement

If mechanical parts are calibrated, it is sometimes enough to know whether the gap is increasing or decreasing.

The following programs offer this option for relative measurement:

- Gap Measure (1-sided),
- Gap Measure (2-sided) Min,
- Gap Measure (2-sided) Max.

Proceed as follows:

➡ Insert the sensor into the gap.

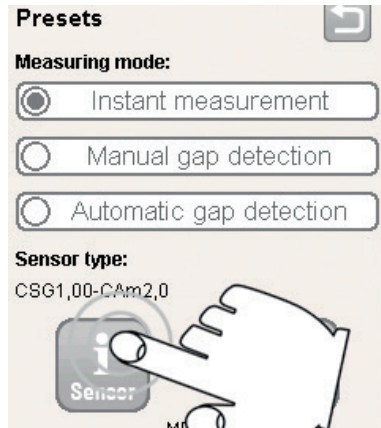
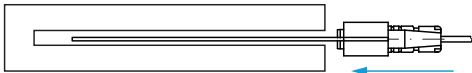

➡ Switch to the menu with the sensor settings.

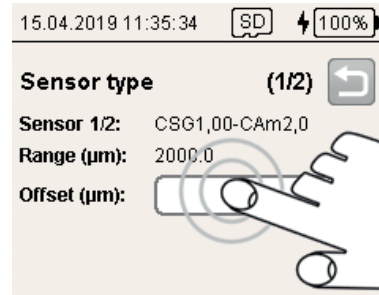

➡ Switch to the menu for setting the offset.

➡ Touch the Offset field.

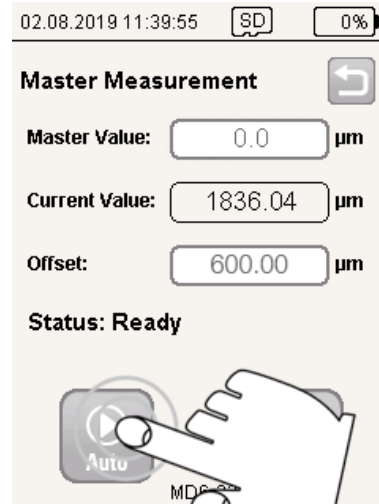

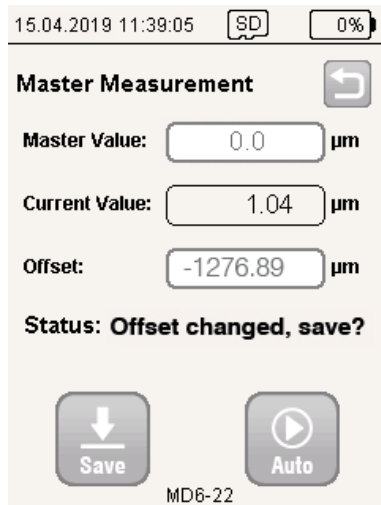

The program routine now switches to the Master Measurement menu.

➡ Touch the  field.





The controller applies the zero master value that is saved in factory defaults and uses it to calculate the current offset value.

- Save the new value for the offset with .
- Return to the Presets menu. To do so, touch  twice.
- Select the desired program and start the measurement.

### Ending Relative Measurement

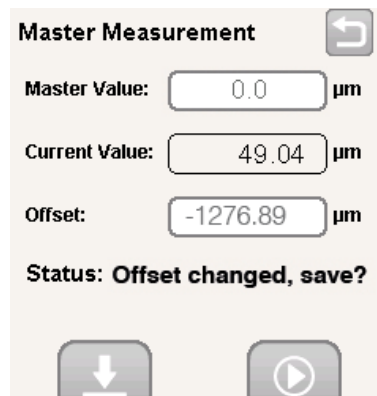
**i** After the controller is restarted, it automatically starts with an absolute measurement.



- Switch to the menu for sensor settings > Master Measurement, see figure.
- Touch the Offset field.
- Enter the thickness of the sensor used in the Offset field.
- Confirm the entry with .

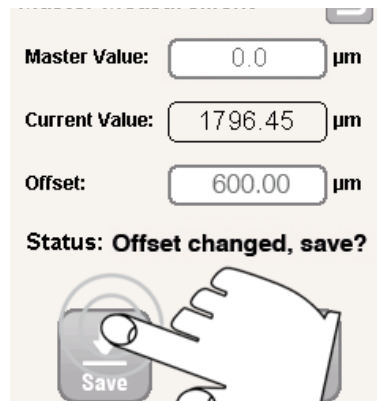

The controller applies the new offset value and uses it to calculate the current absolute gap width.

- Save the new value for the offset with .

This ends relative measurement.

## 7. Maintenance

Make sure that the sensor surface is always clean.

➡ Switch off the power supply before cleaning.

➡ Clean with a clamp cloth; then rub the sensor surface dry.



Disconnect the power supply before touching the sensor surface.

> Static discharge

> Risk of injury

If the controller, sensor or sensor cable is defective, please send us the affected parts for repair or exchange. If the cause of a fault cannot be clearly identified, please send the entire measuring system to:

MICRO-EPSILON MESSTECHNIK  
GmbH & Co. KG  
Koenigbacher Str. 15  
94496 Ortenburg / Germany

Tel. +49 (0) 8542 / 168-0  
Fax +49 (0) 8542 / 168-90  
[info@micro-epsilon.com](mailto:info@micro-epsilon.com)  
[www.micro-epsilon.com](http://www.micro-epsilon.com)

Sensors of the same type can be replaced without calibrating the controller.

## **8. Liability for Material Defects**

All components of the device have been checked and tested for functionality at the factory. However, if defects occur despite our careful quality control, MICRO-EPSILON or your dealer must be notified immediately.

The liability for material defects is 12 months from delivery. Within this period, defective parts, except for wearing parts, will be repaired or replaced free of charge, if the device is returned to MICRO-EPSILON with shipping costs prepaid. Any damage that is caused by improper handling, the use of force or by repairs or modifications by third parties is not covered by the liability for material defects. Repairs are carried out exclusively by MICRO-EPSILON.

Further claims can not be made. Claims arising from the purchase contract remain unaffected. In particular, MICRO-EPSILON shall not be liable for any consequential, special, indirect or incidental damage.

In the interest of further development, MICRO-EPSILON reserves the right to make design changes without notification.

For translations into other languages, the German version shall prevail.

## **9. Decommissioning, Disposal**

 Remove the power supply from the controller.

Incorrect disposal may cause harm to the environment.

 Dispose of the device, its components and accessories, as well as the packaging materials in compliance with the applicable country-specific waste treatment and disposal regulations of the region of use.





MICRO-EPSILON MESSTECHNIK GmbH & Co. KG  
Koenigbacher Str. 15 · 94496 Ortenburg / Germany  
Tel. +49 (0) 8542 / 168-0 · Fax +49 (0) 8542 / 168-90  
info@micro-epsilon.com · www.micro-epsilon.com  
Your local contact: [www.micro-epsilon.com/contact/worldwide/](http://www.micro-epsilon.com/contact/worldwide/)

X9751396-A012050SWE

© MICRO-EPSILON MESSTECHNIK

